

M_k = max. tilting moment
 F_a = axial load

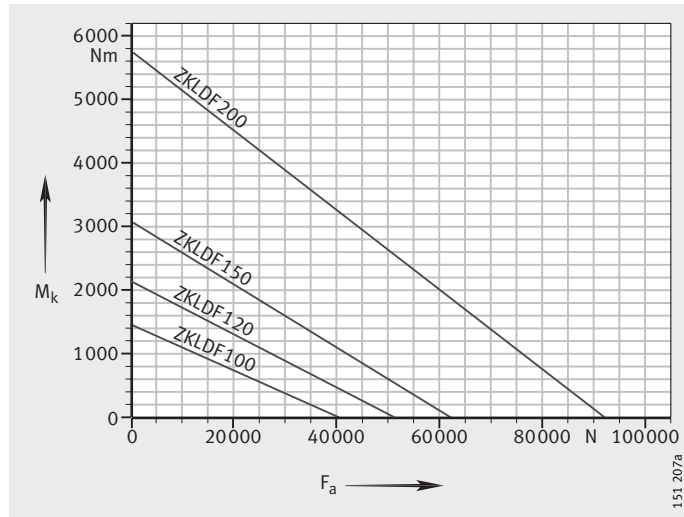

Figure 10

Static limiting load diagram –
 ZKLDF100 to ZKLDF200

M_k = max. tilting moment
 F_a = axial load

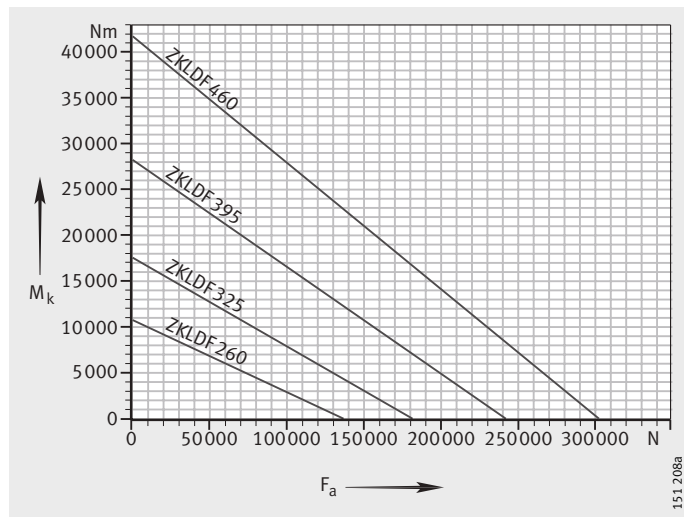

Figure 11

Static limiting load diagram –
 ZKLDF260 to ZKLDF460

Axial/radial bearings

Axial angular contact ball bearings

Limiting speeds

The bearings allow the limiting speeds n_G given in the dimension tables. The operating temperatures occurring are heavily dependent on the environmental conditions. Calculation is possible by means of a thermal balance analysis based on frictional torque data.

Caution! If the environmental conditions deviate from the specifications in relation to, for example, adjacent construction tolerances, lubrication, ambient temperature/heat dissipation or differ from the operating conditions normal for machine tools, checking must be carried out again. Please contact us.

Bearing preload

Once the bearings have been fitted and fully screw mounted, they are radially and axially clearance-free and preloaded.

Temperature differences

Temperature differences between the shaft and housing influence the radial bearing preload and thus the operating behaviour of the bearing arrangement.

If the shaft temperature is higher than the housing temperature, the radial preload will increase proportionally, so there will be an increase in the rolling element load, bearing friction and bearing temperature.

If the shaft temperature is lower than the housing temperature, the radial preload will decrease proportionally, so the rigidity will decrease to bearing clearance and wear will increase.

Frictional torque

The bearing frictional torque M_{RL} is influenced primarily by the viscosity and quantity of the lubricant and the bearing preload:

- The lubricant viscosity and quantity are dependent on the lubricant grade and operating temperature.
- The bearing preload is dependent on the mounting fits, the geometrical accuracy of the adjacent parts, the temperature difference between the inner and outer ring, the screw tightening torque and the mounting situation (bearing inner ring axially supported on one or both sides).

The frictional torques M_{RL} in the dimension tables are statistically determined guide values for bearings with grease lubrication (measurement speed $n_{const} = 5 \text{ min}^{-1}$). Figure 12 shows measured frictional torques for mounting with an unsupported L-section ring for YRT_{Speed} .

Caution! Any deviations in the tightening torque of the fixing screws will have a detrimental effect on the preload and the frictional torque.

M_{RL} = frictional torque
n = speed

Figure 12

Frictional torques as guide values for YRT_{Speed} – statistically determined values from series of measurements

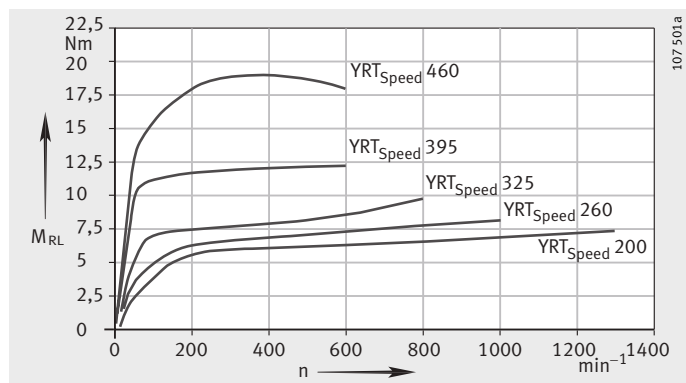

Frictional torque and dimensioning of the drive

Caution!

For YRT and RTC bearings, it must be taken into consideration that the frictional torque can increase by a factor of 2 to 2,5 with increasing speed.

For ZKLDF bearings, it must be taken into consideration that the starting frictional torque can be 1,5 times as high as the values M_{RL} in the dimension tables.

Lubrication

Axial/radial bearings YRT, RTC and YRT_{Speed} can be relubricated via the L-section ring and outer ring.

Axial angular contact ball bearings ZKLDF can be relubricated via the outer ring.

The initial greasing is compatible with lubricating oils having a mineral oil base.

For calculation of the relubrication quantities and intervals based on a stated load spectrum (speed, load, operating duration) and the environmental conditions, please contact us.

Overlubrication

If the bearing is inadvertently overlubricated, the bearing frictional torque and temperature will increase.

In order to achieve the original frictional torque again, a running-in cycle in accordance with *Figure 13* should be applied.

Caution!

Please note the further information on lubrication in *Technical Principles, Lubrication*.

n_G = limiting speed according to dimension tables
 t = time

Figure 13

Running-in cycle after overlubrication

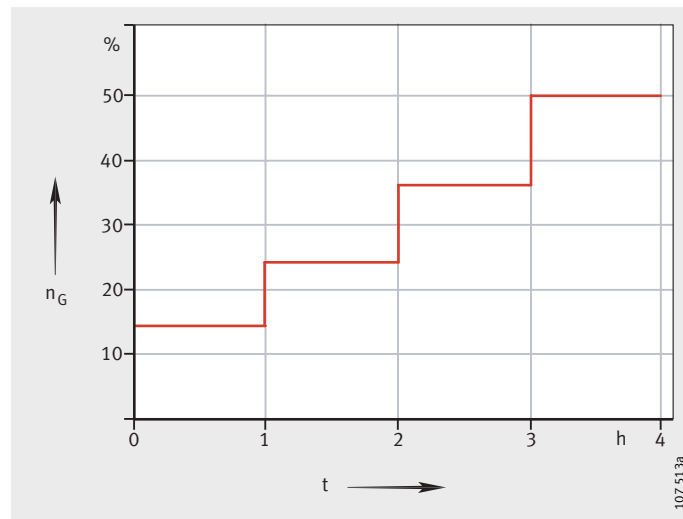

Axial/radial bearings Axial angular contact ball bearings

Design of adjacent construction

Caution!

YRT, RTC, YRT_{Speed} and ZKLDF have the same mounting dimensions.

Geometrical defects in the screw mounting surfaces and fits will influence the running accuracy, preload and running characteristics of the bearing arrangement. The accuracy of the adjacent surfaces must therefore be matched to the overall accuracy requirement of the subassembly.

The adjacent construction should be produced in accordance with *Figure 14* and the tolerances must be in accordance with the tables from page 1006. Any deviations will influence the bearing frictional torque, running accuracy and running characteristics.

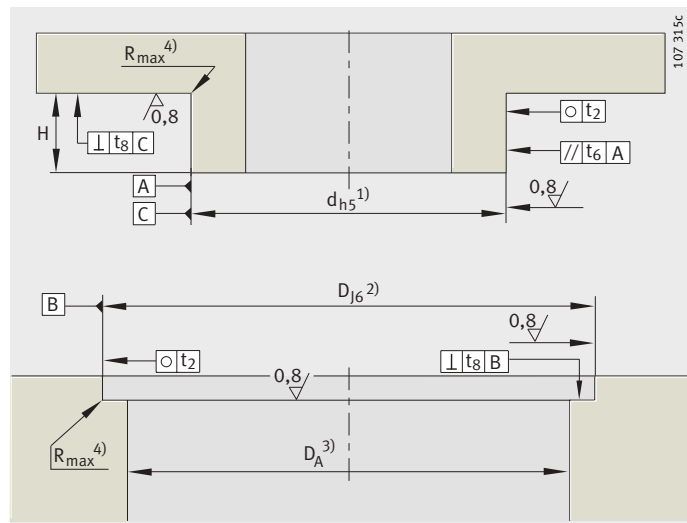

Figure 14
Requirements for the adjacent construction – YRT, RTC, YRT_{Speed}, ZKLDF

Legend to *Figure 14*

- 1) Support over whole bearing height. It must be ensured that the means of support has adequate rigidity.
- 2) A precise fit is only necessary if radial support due to the load or a precise bearing position is required.
- 3) Note the bearing diameter D_1 according to the dimension tables. Ensure that there is sufficient distance between the rotating bearing rings and the adjacent construction.
- 4) For values, see table Maximum corner radii of fit surfaces, page 1007.

Fits

The selection of fits leads to transition fits, i.e. depending on the actual dimensional position of the bearing diameter and mounting dimensions, clearance fits or interference fits can arise.

Caution!

The fit influences, for example, the running accuracy of the bearing and its dynamic characteristics.

An excessively tight fit will increase the radial bearing preload. This means that:

- there is an increase in bearing friction and heat generation in the bearing as well as the load on the raceway system and wear
- there will be a decrease in the achievable speed and the bearing operating life.

In order to achieve very high running accuracy, the fit clearance should be as close as possible to zero.

For easier matching of the adjacent construction to the actual bearing dimensions, each bearing of series RTC and YRT_{Speed} is supplied with a measurement record (this is supplied by agreement for other series).

Recommended fits for shafts

The shaft should be produced to tolerance zone h5 and for series YRT_{Speed} in accordance with the table, page 1007. If there are special requirements, the fit clearance must be further restricted within the tolerance zone h5:

- Requirements for running accuracy:
 - For maximum running accuracy and a rotating bearing inner ring, the fit clearance should be as close as possible to zero. The fit clearance may otherwise increase the bearing runout. With normal requirements for running accuracy or a static bearing inner ring, the shaft should be produced to h5.
- Requirements for dynamic characteristics:
 - For swivel type operation ($n \times d < 35\,000$, operating duration $ED < 10\%$) the shaft should be produced to h5.
 - For higher speeds and longer operating durations, the fit clearance must not exceed 0,01 mm. For series YRT_{Speed}, the fit clearance must not exceed 0,005 mm.

For series ZKLDF, the fit clearance should be based on the inner ring with the smallest bore dimension.

Recommended fits for housings

The housing should be produced to tolerance zone J6, for series YRT_{Speed} in accordance with the table Recommended fits, page 1007. If there are special requirements, the fit clearance must be further restricted within the tolerance zone J6:

- Requirements for running accuracy:
 - For maximum running accuracy and a rotating bearing outer ring, the fit clearance should be as close as possible to zero. With a static bearing outer ring, a clearance fit or a design without radial centring should be selected.
- Requirements for dynamic characteristics:
 - For predominantly swivel type operation ($n \times d < 35\,000$, operating duration $ED < 10\%$) and a rotating bearing outer ring, the housing fit should be produced to J6.
 - For higher speeds and longer operating duration, the bearing outer ring should not be radially centred or the housing fit should be produced as a clearance fit with at least 0,02 mm clearance. This reduces the increase in preload when heat is generated in the bearing position.



Fit selection depending on the screw connection of the bearing rings

If the bearing outer ring is screw mounted on the static component, a fit seating is not required or a fit seating in accordance with the table Recommended fits for adjacent construction, page 1007, can be produced. If the values in the table are used, this will give a transition fit with a tendency towards clearance fit. This generally allows easy fitting.

If the bearing inner ring is screw mounted on the static component, it should nevertheless for functional reasons be supported by the shaft over the whole bearing height. The shaft dimensions should then be selected in accordance with the tables from page 1006. If these values in the table are used, this will give a transition fit with a tendency towards clearance fit.

Axial/radial bearings Axial angular contact ball bearings

Geometrical and positional accuracy of the adjacent construction

The values given in the following tables for the geometrical and positional accuracy of the adjacent construction have proved effective in practice and are adequate for the majority of applications.

Caution!

The geometrical tolerances influence the axial and radial runout accuracy of the subassembly as well as the bearing frictional torque and the running characteristics.

Geometrical and positional accuracy for shafts – YRT, RTC, ZKLDF

Nominal shaft diameter d mm		Deviation d for tolerance zone h5 μm	Roundness Parallelism Perpendicularity t ₂ , t ₆ , t ₈ μm
over	incl.		
50	80	⁰ -13	3
80	120	⁰ -15	4
120	150	⁰ -18	5
150	180	⁰ -18	5
180	250	⁰ -20	7
250	315	⁰ -23	8
315	400	⁰ -25	9
400	500	⁰ -27	10
500	630	⁰ -28	11
630	800	⁰ -32	12
800	1000	⁰ -36	14

Geometrical and positional accuracy for housings – YRT, RTC, ZKLDF

Nominal housing bore diameter D mm		Deviation D for tolerance zone J6 μm	Roundness Perpendicularity t ₂ , t ₈ μm
over	incl.		
120	150	⁺¹⁸ -7	5
150	180	⁺¹⁸ -7	5
180	250	⁺²² -7	7
250	315	⁺²⁵ -7	8
315	400	⁺²⁹ -7	9
400	500	⁺³³ -7	10
500	630	⁺³⁴ -7	11
630	800	⁺³⁸ -8	12
800	1000	⁺⁴⁴ -12	14
1000	1250	⁺⁵² -14	16

Recommended fits for shaft and housing bore – YRT_{Speed}

Axial/radial bearing	Shaft diameter d mm	Housing bore D mm
YRT _{Speed} 200	200 ^{-0,01} _{-0,024}	300 ^{+0,011} _{-0,005}
YRT _{Speed} 260	260 ^{-0,013} _{-0,029}	385 ^{+0,013} _{-0,005}
YRT _{Speed} 325	325 ^{-0,018} _{-0,036}	450 ^{+0,015} _{-0,005}
YRT _{Speed} 395	395 ^{-0,018} _{-0,036}	525 ^{+0,017} _{-0,005}
YRT _{Speed} 460	460 ^{-0,018} _{-0,038}	600 ^{+0,017} _{-0,005}

Geometrical and positional accuracy for shafts – YRT_{Speed}

Axial/radial bearing	Roundness t ₂ μm	Parallelism t ₆ μm	Perpendicularity t ₈ μm
YRT _{Speed} 200	6	5	5
YRT _{Speed} 260 to YRT _{Speed} 460	8	5	7

Geometrical and positional accuracy for housings – YRT_{Speed}

Axial/radial bearing	Roundness t ₂ μm	Perpendicularity t ₈ μm
YRT _{Speed} 200 to YRT _{Speed} 460	6	8

Maximum corner radii of fit surfaces – YRT, RTC, YRT_{Speed}, ZKLDF

Bore diameter d mm	Max. corner radius R _{max} mm
50 incl. 150	0,1
over 150 incl. 460	0,3
over 460 incl. 950	1



Mounting dimensions H₁, H₂

Caution!

If the height variation must be as small as possible, the H₁ dimensional tolerance must conform to the tables, page 1010, page 1011 and *Figure 15*.

The mounting dimension H₂ defines the position of any worm wheel used, *Figure 15*, see also *Figure 16*, L-section ring with support ring.

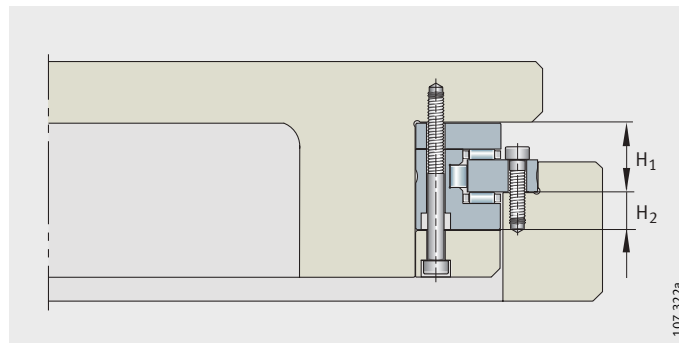

Figure 15
Mounting dimension H₁, H₂

107 322a

Axial/radial bearings Axial angular contact ball bearings

L-section ring without support ring / with support ring

The L-section ring of bearings YRT and RTC can be mounted unsupported or supported over its whole surface, *Figure 16*. If the L-section ring is supported, the tilting rigidity is higher. The support ring (e.g. worm wheel) must be ordered separately.

Depending on the application, series YRT and RTC require bearings with a different preload match in order to achieve the same preload forces in the axial bearing.

For series YRT_{Speed} and ZKLDF, there is only one preload match. The increase in rigidity and friction in YRT_{Speed} bearings is small and can normally be ignored.

In bearings of series ZKLDF, the rigidity and frictional torque are not influenced by the support ring.

L-section ring without support ring

For an arrangement “L-section ring without support ring”, the bearing designation is:

- YRT <bore diameter> or
- RTC <bore diameter>.

L-section ring with support ring

For an arrangement “L-section ring with support ring”, the bearing designation is:

- YRT <bore diameter> **VSP**
- RTC <bore diameter> **EB**.

For RTC with an additionally restricted axial and radial runout, the bearing designation is:

- RTC <bore diameter> **T52EA**.

Caution!

For bearing arrangements with a supported L-section ring, only bearings with the suffix VSP, EB or T52EA can be ordered. If the normal design is mounted with a supported L-section ring, there will be a considerable increase in the bearing frictional torque. The support ring should be at least twice as high as the shaft locating washer of the bearing.

YRT
RTC

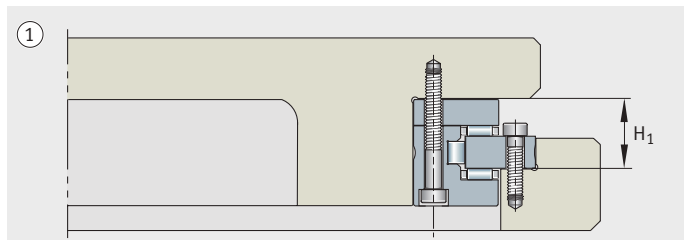

YRT..VSP
RTC..EB
RTC..T52EA

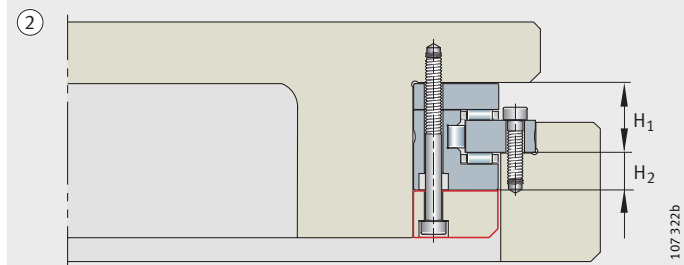

Figure 16
① L-section ring
without support ring,
② L-section ring
with support ring/
for YRT, RTC

107 322b

Fitting Retaining screws secure the bearing components during transport. For easier centring of the bearing, the screws should be loosened before fitting and either secured again or removed after fitting. Tighten the fixing screws in crosswise sequence using a torque wrench in three stages to the specified tightening torque M_A , while rotating the bearing ZKLDF, *Figure 17*:

- Stage 1 40% of M_A
- Stage 2 70% of M_A
- Stage 3 100% of M_A .

Observe the correct grade of the fixing screws.

Caution! Mounting forces must only be applied to the bearing ring to be fitted, never through the rolling elements.

Bearing components must not be separated or interchanged during fitting and dismantling.

If the bearing is unusually difficult to move, loosen the fixing screws and tighten them again in steps in a crosswise sequence. This will eliminate any distortion.

Bearings should only be fitted in accordance with TPI 103, Fitting and Maintenance Manual.

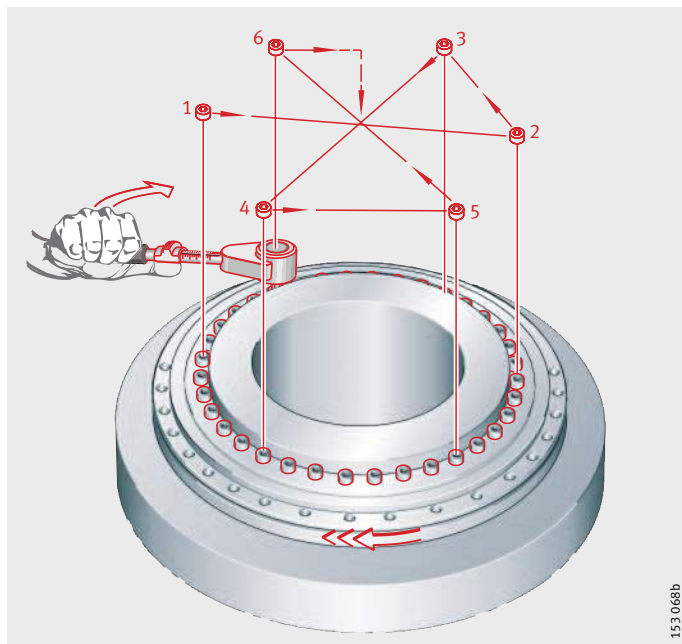

Figure 17
Tightening of fixing screws

Axial/radial bearings

Axial angular contact ball bearings

Accuracy The dimensional tolerances are derived from tolerance class P5. The running tolerances correspond to P4 in accordance with DIN 620, see table Dimensional tolerances, mounting dimensions, axial and radial runout. The axial and radial runout accuracy is influenced by:

- the running accuracy of the bearing
- the geometrical accuracy of the adjacent surfaces
- the fit between the rotating bearing ring and the adjacent component.

Caution! In order to achieve very high running accuracy, the fit clearance should be as close as possible to zero.

The bearing bore in the series YRT, RTC and YRT_{Speed} may be slightly conical when delivered. This is typical of the bearing design and is a result of the radial bearing preload forces. The bearing will regain its ideal geometry when fitted.

Dimensional tolerances, mounting dimensions, axial and radial runout – YRT, ZKLDF

Dimensional tolerances				Mounting dimensions					Axial and radial runout ¹⁾	
Bore		Outside diameter		H ₁	Δ _{H1s}	Re-strict-ed ²⁾	H ₂	Re-strict-ed ²⁾	Nor-mal	Re-strict-ed ²⁾
d	Δ _{ds}	D	Δ _{Ds}							
50	-0,008	126	-0,011	20	±0,125	±0,025	10	±0,02	2	1
80	-0,009	146	-0,011	23,35	±0,15	±0,025	11,7	±0,02	3	1,5
100	-0,01	185	-0,015	25	±0,175	±0,025	13	±0,02	3	1,5
120	-0,01	210	-0,015	26	±0,175	±0,025	14	±0,02	3	1,5
150	-0,013	240	-0,015	26	±0,175	±0,03	14	±0,02	3	1,5
180	-0,013	280	-0,018	29	±0,175	±0,03	14	±0,025	4	2
200	-0,015	300	-0,018	30	±0,175	±0,03	15	±0,025	4	2
260	-0,018	385	-0,02	36,5	±0,2	±0,04	18,5	±0,025	6	3
325	-0,023	450	-0,023	40	±0,2	±0,05	20	±0,025	6	3
395	-0,023	525	-0,028	42,5	±0,2	±0,05	22,5	±0,025	6	3
460	-0,023	600	-0,028	46	±0,225	±0,06	24	±0,03	6	3
580	-0,025	750	-0,035	60	±0,25	±0,075	30	±0,03	10	5 ³⁾
650	-0,038	870	-0,05	78	±0,25	±0,1	44	±0,03	10	5 ³⁾
850	-0,05	1095	-0,063	80,5	±0,3	±0,12	43,5	±0,03	12	6 ³⁾
950	-0,05	1200	-0,063	86	±0,3	±0,12	46	±0,03	12	6 ³⁾
1030	-0,063	1300	-0,08	92,5	±0,3	±0,15	52,5	±0,03	12	6 ³⁾

1) For rotating inner and outer ring, measured on fitted bearing, with ideal adjacent construction.

2) Special design, YRT only.

3) By agreement only for rotating outer ring.

**Dimensional tolerances,
mounting dimensions,
axial and radial runout –
RTC**

Dimensional tolerances						Mounting dimensions		Axial and radial runout ¹⁾ Normal	Axial run-out ¹⁾ Re-strict-ed
Bore		Outside diameter		Bearing height		H ₁	Δ _{H1s}		
d	Δ _{ds}	D	Δ _{Ds}	H	Δ _{Hs}			H ₁	Δ _{H1s}
mm	mm	mm	mm	mm	mm	mm	mm		
80	-0,009	146	-0,011	35	+0,025 -0,15	23,35	±0,025	3	1,5
100	-0,01	185	-0,015	38	+0,025 -0,15	25	±0,025	3	1,5
120	-0,01	210	-0,015	40	+0,03 -0,175	26	±0,025	3	1,5
150	-0,013	240	-0,015	40	+0,03 -0,175	26	±0,03	3	1,5
180	-0,013	280	-0,018	43	+0,03 -0,175	29	±0,03	4	2
200	-0,015	300	-0,018	45	+0,03 -0,175	30	±0,03	4	2
260	-0,018	385	-0,020	55	+0,04 -0,25	36	±0,04	5	3
325	-0,023	450	-0,023	60	+0,05 -0,3	40	±0,05	5	3
395	-0,023	525	-0,028	65	+0,05 -0,3	42,5	±0,05	5	3
460	-0,027	600	-0,028	70	+0,06 -0,35	46	±0,06	6	3

¹⁾ For rotating inner and outer ring, measured on fitted bearing, with ideal adjacent construction.

**Dimensional tolerances, mounting
dimensions, axial and radial runout
– YRT_{Speed}**

Dimensional tolerances				Mounting dimensions			Axial and radial runout ¹⁾
Bore		Outside diameter		H ₁	Δ _{H1s}	H ₂	
d	Δ _{ds}	D	Δ _{Ds}				H ₁
mm	mm	mm	mm	mm	mm	mm	μm
200	-0,015	300	-0,018	30	+0,04 -0,06	15	4
260	-0,018	385	-0,02	36,5	+0,05 -0,07	18,5	6
325	-0,023	450	-0,023	40	+0,06 -0,07	20	6
395	-0,023	525	-0,028	42,5	+0,06 -0,07	22,5	6
460	-0,023	600	-0,028	46	+0,07 -0,08	24	6

¹⁾ For rotating inner and outer ring, measured on fitted bearing, with ideal adjacent construction.



Special designs

Available by agreement:

For YRT, axial and radial runout tolerance restricted by 50%.

Additional text: axial/radial runout 50%.

For RTC, axial runout tolerance restricted by 50%.

Additional text: axial runout 50%.

For YRT, closer tolerance on mounting dimension H₁ and H₂.

Additional text: H₁ with tolerance ± ..., H₂ with tolerance ± ...

For restricted tolerance value, see table, page 1010.

Axial/radial bearings

Double direction

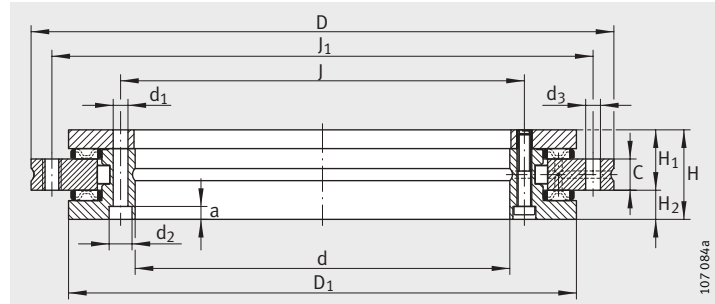

YRT

Dimension table · Dimensions in mm																
Designation	Mass m ≈ kg	Dimensions									Fixing holes					
		d	D	H	H ₁	H ₂	C	D ₁	J	J ₁	Inner ring				Outer ring	
											d ₁	d ₂	a	Quantity ⁴⁾	d ₃	Quantity ⁴⁾
YRT50	1,6	50	126	30	20	10	10	105	63	116	5,6	–	–	10	5,6	12
YRT80-TV⁵⁾	2,4	80	146	35	23,35	11,65	12	130	92	138	5,6	10	4	10	4,6	12
YRT100⁵⁾	4,1	100	185	38	25	13	12	160	112	170	5,6	10	5,4	16	5,6	15
YRT120	5,3	120	210	40	26	14	12	184	135	195	7	11	6,2	22	7	21
YRT150	6,2	150	240	40	26	14	12	214	165	225	7	11	6,2	34	7	33
YRT180	7,7	180	280	43	29	14	15	244	194	260	7	11	6,2	46	7	45
YRT200	9,7	200	300	45	30	15	15	274	215	285	7	11	6,2	46	7	45
YRT260	18,3	260	385	55	36,5	18,5	18	345	280	365	9,3	15	8,2	34	9,3	33
YRT325⁵⁾	25	325	450	60	40	20	20	415	342	430	9,3	15	8,2	34	9,3	33
YRT395	33	395	525	65	42,5	22,5	20	486	415	505	9,3	15	8,2	46	9,3	45
YRT460	45	460	600	70	46	24	22	560	482	580	9,3	15	8,2	46	9,3	45
YRT580	89	580	750	90	60	30	30	700	610	720	11,4	18	11	46	11,4	42
YRT650	170	650	870	122	78	44	34	800	680	830	14	20	13	46	14	42
YRT850	253	850	1095	124	80,5	43,5	37	1018	890	1055	18	26	17	58	18	54
YRT950 ⁷⁾	312	950	1200	132	86	46	40	1130	990	1160	18	26	17	58	18	54
YRT1030	375	1 030	1300	145	92,5	–	40	1215	1075	1255	18	26	17	60	18	66

- 1) Including retaining screws and threaded extraction holes.
- 2) Tightening torque for screws to DIN 912, grade 10.9.
- 3) Rigidity values taking account of the rolling element set, deformation of the bearing rings and the screw connections.
- 4) Caution!
For fixing holes in the adjacent construction.
Pay attention to the pitch of the bearing holes.
- 5) Screw counterbores in the L-section ring open to the bearing bore (see figure, page 1013).
Bearing inside diameter is unsupported in this area ②.
- 6) For high operating durations or continuous operation, please contact us.
- 7) Available by agreement only.

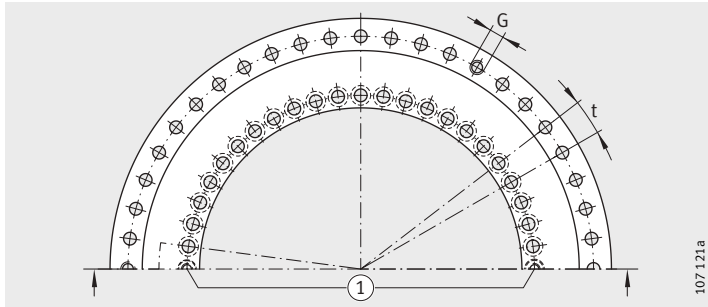

Hole pattern

① Two retaining screws per size

Pitch $t^{1)}$	Threaded extraction hole		Screw tightening torque $M_A^{2)}$ Nm	Basic load ratings				Limiting speed ⁶⁾ n_G min ⁻¹	Bearing frictional torque M_{RL} Nm	Axial rigidity ³⁾ c_{aL} kN/ μ m	Radial rigidity ³⁾ c_{rL} kN/ μ m	Tilting rigidity ³⁾ c_{kL} kNm/mrad
	G	Quantity		axial		radial						
				dyn. C_a N	stat. C_{0a} N	dyn. C_r N	stat. C_{0r} N					
12X30°	–	–	8,5	56 000	280 000	28 500	49 500	440	2,5	1,3	1,1	1,25
12X30°	–	–	8,5/4,5	38 000	158 000	44 000	98 000	350	3	1,6	1,8	2,5
18X20°	M5	3	8,5	73 000	370 000	52 000	108 000	280	3	2	2	5
24X15°	M8	3	14	80 000	445 000	70 000	148 000	230	7	2,1	2,2	7
36X10°	M8	3	14	85 000	510 000	77 000	179 000	210	13	2,3	2,6	11
48X 7,5°	M8	3	14	92 000	580 000	83 000	209 000	190	14	2,6	3	17
48X 7,5°	M8	3	14	98 000	650 000	89 000	236 000	170	15	3	3,5	23
36X10°	M12	3	34	109 000	810 000	102 000	310 000	130	25	3,5	4,5	45
36X10°	M12	3	34	186 000	1 710 000	134 000	415 000	110	48	4,3	5	80
48X 7,5°	M12	3	34	202 000	2 010 000	133 000	435 000	90	55	4,9	6	130
48X 7,5°	M12	3	34	217 000	2 300 000	187 000	650 000	80	70	5,7	7	200
48X 7,5°	M12	6	68	390 000	3 600 000	211 000	820 000	60	140	6,9	9	380
48X 7,5°	M12	6	116	495 000	5 200 000	415 000	1 500 000	55	200	7,6	10	550
60X 6°	M12	6	284	560 000	6 600 000	475 000	1 970 000	40	300	9,3	13	1 100
60X 6°	M12	6	284	1 040 000	10 300 000	600 000	2 450 000	40	600	10,4	14	1 500
72X 5°	M16	6	284	1 080 000	11 000 000	620 000	2 650 000	35	800	11,2	16	1 900

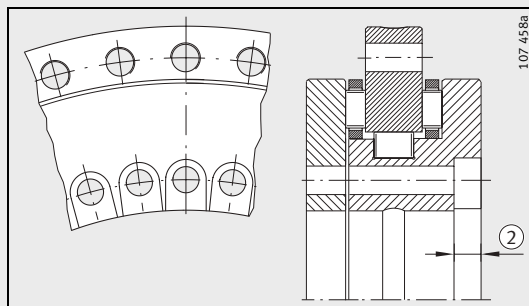

Screw counterbore open

Bearing inside diameter unsupported in area ②

Axial/radial bearings

Double direction

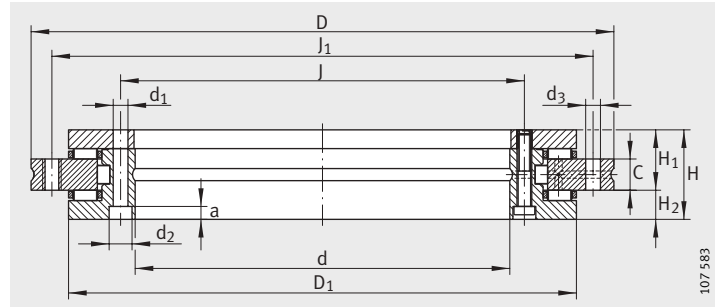

RTC

Dimension table · Dimensions in mm															
Designation	Mass m ≈kg	Dimensions ⁷⁾								Fixing holes					
		d	D	H	H ₁	C	D ₁	J	J ₁	Inner ring				Outer ring	
										d ₁	d ₂	a	Quantity ⁴⁾	d ₃	Quantity ⁴⁾
RTC80⁵⁾	2	80	146	35	23,35	12	130	92	138	5,6	10	5,7	12	4,6	12
RTC100⁵⁾	4	100	185	38	25	12	160	112	170	5,6	10	5,7	15	5,6	18
RTC120	5	120	210	40	26	12	184	135	195	7	11	7	21	7	24
RTC150	5,8	150	240	40	26	12	212	165	225	7	11	7	33	7	36
RTC180	8	180	280	43	29	15	242	194	260	7	11	7	45	7	48
RTC200	9,3	200	300	45	30	15	272	215	285	7	11	7	45	4	48
RTC260	18	260	385	55	36,5	18	343	280	365	9,3	15	9,3	33	9,3	36
RTC325⁵⁾	25	325	450	60	40	20	413	342	430	9,3	15	9,3	33	9,3	36
RTC395	33	395	525	65	42,5	20	484	415	505	9,3	15	9,3	45	9,3	48
RTC460	48	460	600	70	46	22	558	482	580	9,3	15	9,3	45	9,3	48

- 1) Including retaining screws and threaded extraction holes.
- 2) Tightening torque for screws to DIN 912, grade 10.9.
- 3) Rigidity values taking account of the rolling element set, deformation of the bearing rings and the screw connections.
- 4) Caution!
For fixing holes in the adjacent construction.
Pay attention to the pitch of the bearing holes.
- 5) Screw counterbores in the L-section ring open to the bearing bore (see figure, page 1015).
Bearing inside diameter is unsupported in this area ③.
- 6) For high operating durations or continuous operation, please contact us.
- 7) Sizes d > 460 mm available by agreement.

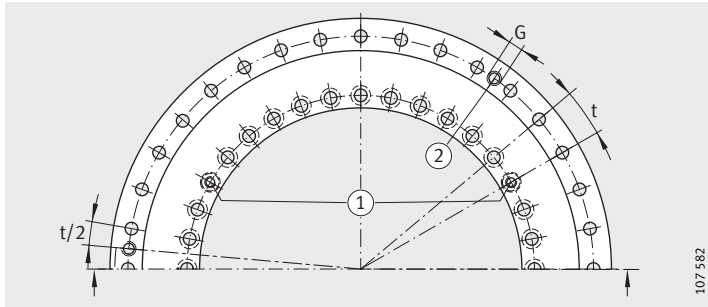

Hole pattern

- ① Retaining screws 3×120°
- ② Threaded extraction holes

Pitch t ¹⁾	Retaining screws	Threaded extraction hole		Screw tightening torque	Basic load ratings				Limiting speed ⁶⁾	Bearing frictional torque	Axial rigidity ³⁾	Radial rigidity ³⁾	Tilting rigidity ³⁾	
		G	Quantity		M _A ²⁾	axial		radial						
						dyn. C _a	stat. C _{0a}	dyn. C _r						stat. C _{0r}
QuantityXt	Quantity			Nm	N	N	N	N	n _G	M _{RL}	C _{aL}	C _{rL}	C _{kL}	
									min ⁻¹	Nm	kN/μm	kN/μm	kNm/mrad	
12X30°	3	–	–	8,5	56 000	255 000	42 500	100 000	530	1	0,71	1,8	1,6	
18X20°	3	M5	3	8,5	76 500	415 000	47 500	120 000	430	4	1,2	2	5	
24X15°	3	M6	3	14	102 000	540 000	52 000	143 000	340	5	1,3	2,2	7	
36X10°	3	M6	3	14	112 000	630 000	56 000	170 000	320	7	1,5	2,6	11	
48X 7,5°	3	M6	3	14	118 000	710 000	69 500	200 000	280	9	1,7	3	17	
48X 7,5°	3	M6	3	14	120 000	765 000	81 500	220 000	260	11	1,8	3,5	23	
36X10°	3	M8	3	34	160 000	1 060 000	93 000	290 000	200	16	2,1	4,5	45	
36X10°	3	M8	3	34	275 000	1 930 000	120 000	345 000	170	27	2,8	5	80	
48X 7,5°	3	M8	3	34	300 000	2 280 000	186 000	655 000	140	42	3,4	6	130	
48X 7,5°	3	M8	3	34	355 000	2 800 000	200 000	765 000	120	55	3,9	7	200	

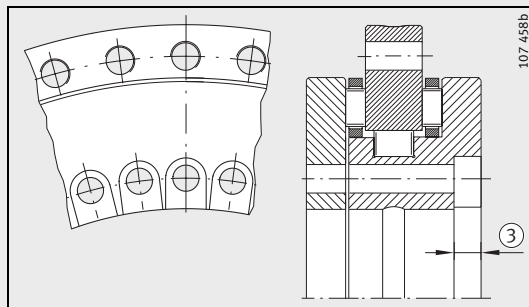

Screw counterbore open
Bearing inside diameter unsupported in area ③

Axial/radial bearings

Double direction

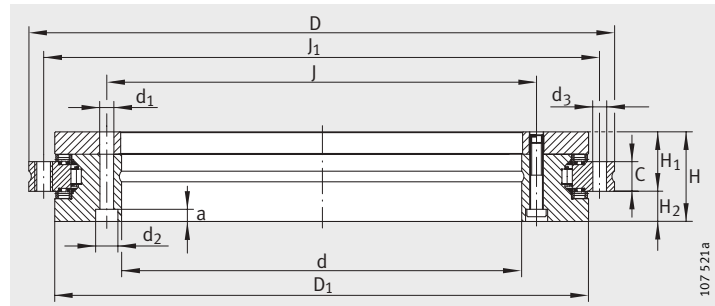

YRT_{Speed}

Dimension table · Dimensions in mm																		
Designation	Mass m ≈kg	Dimensions										Fixing holes						Retaining screws Quantity
		d	D	H	H ₁	H ₂	C	D ₁	J	J ₁	Inner ring				Outer ring			
											d ₁	d ₂	a	Quantity ³⁾	d ₃	Quantity ³⁾		
YRTS200	9,7	200_{-0,015}	300 _{-0,018}	45	30	15	15	274	215	285	7	11	6,2	46	7	45	2	
YRTS260	18,3	260_{-0,018}	385 _{-0,02}	55	36,5	18,5	18	345	280	365	9,3	15	8,2	34	9,3	33	2	
YRTS325⁵⁾	25	325_{-0,023}	450 _{-0,023}	60	40	20	20	415	342	430	9,3	15	8,2	34	9,3	33	2	
YRTS395	33	395_{-0,023}	525 _{-0,028}	65	42,5	22,5	20	486	415	505	9,3	15	8,2	46	9,3	45	2	
YRTS460	45	460_{-0,023}	600 _{-0,023}	70	46	24	22	560	482	580	9,3	15	8,2	46	9,3	45	2	

1) Including retaining screws and threaded extraction holes.

2) For screws to DIN 912, grade 10.9.

3) Caution!

For fixing holes in the adjacent construction.
Pay attention to the pitch of the bearing holes.

4) Rigidity values taking account of the rolling element set, deformation of the bearing rings and the screw connections.

5) Screw counterbores in the L-section ring open to the bearing bore, see figure, page 1017.
Bearing inside diameter is unsupported in this area ②.

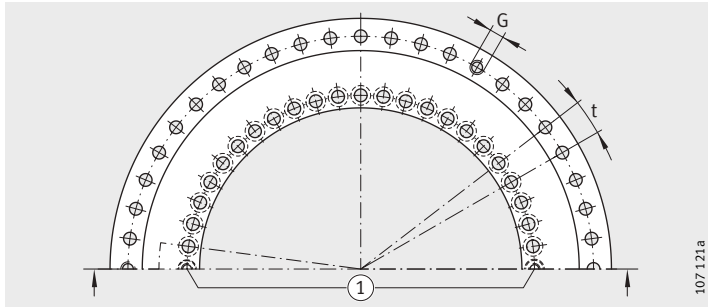

Hole pattern
 ① Retaining screws

Pitch t ¹⁾	Threaded extraction hole		Screw tightening torque M _A ²⁾ Nm	Basic load ratings				Limiting speed n _G min ⁻¹	Axial rigidity ⁴⁾ c _{aL} kN/μm	Radial rigidity ⁴⁾ c _{rL} kN/μm	Tilting rigidity ⁴⁾ c _{kL} kNm/mrad	Mass moment of inertia for rotating	
	G	Quantity		axial		radial						Inner ring IR M _M kg · cm ²	Outer ring AU kg · cm ²
				dyn. C _a N	stat. C _{0a} N	dyn. C _r N	stat. C _{0r} N						
48X 7,5°	M8	3	14	155 000	840 000	94 000	226 000	1 160	4	1,2	29	667	435
36X10°	M12	3	34	173 000	1 050 000	110 000	305 000	910	5,4	1,6	67	2 074	1 422
36X10°	M12	3	34	191 000	1 260 000	109 000	320 000	760	6,6	1,8	115	4 506	2 489
48X 7,5°	M12	3	34	214 000	1 540 000	121 000	390 000	650	7,8	2	195	8 352	4 254
48X 7,5°	M12	3	34	221 000	1 690 000	168 000	570 000	560	8,9	1,8	280	15 738	7 379

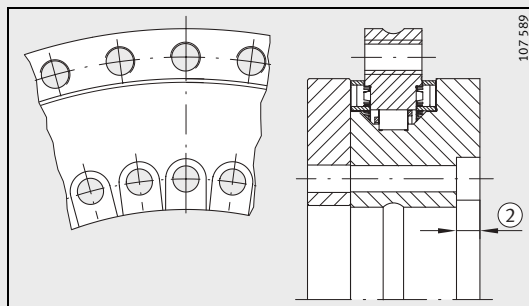

Screw counterbore open
 Bearing inside diameter unsupported in area ②

Axial angular contact ball bearings

Double direction

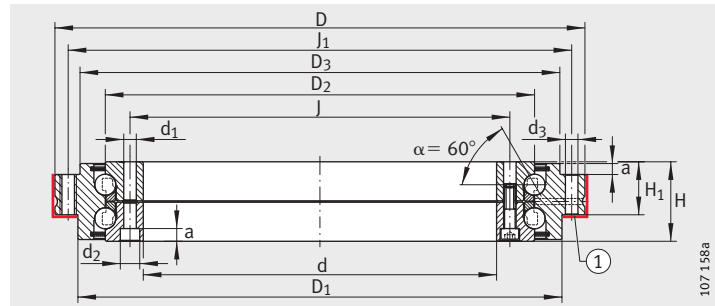

ZKLDF

① Contact surface/centring diameter

Dimension table · Dimensions in mm															
Designation	Mass m ≈ kg	Dimensions										Inner ring			
		d	D	H	H ₁	D ₁	D ₂	D ₃	J	J ₁	a	Fixing holes			Retain- ing screws
												d ₁	d ₂	Quan- tity ⁴⁾	Quan- tity
ZKLDF100 ⁵⁾	4,5	100	185	38	25	160	136	158	112	170	5,4	5,6	10	16	2
ZKLDF120	6	120	210	40	26	184	159	181	135	195	6,2	7	11	22	2
ZKLDF150	7,5	150	240	40	26	214	188	211	165	225	6,2	7	11	34	2
ZKLDF200	11	200	300	45	30	274	243	271	215	285	6,2	7	11	46	2
ZKLDF260	22	260	385	55	36,5	345	313	348	280	365	8,2	9,3	15	34	2
ZKLDF325 ⁵⁾	28	325	450	60	40	415	380	413	342	430	8,2	9,3	15	34	2
ZKLDF395	39	395	525	65	42,5	486	450	488	415	505	8,2	9,3	15	46	2
ZKLDF460 ⁶⁾	50	460	600	70	46	560	520	563	482	580	8,2	9,3	15	46	2

- 1) Including retaining screws and threaded extraction holes.
- 2) Tightening torque for screws to DIN 912, grade 10.9.
- 3) Rigidity values taking account of the rolling element set, deformation of the bearing rings and the screw connections.
- 4) Caution!
For fixing holes in the adjacent construction.
Pay attention to the pitch of the bearing holes.
- 5) Screw counterbores in the L-section ring open to the bearing bore, see figure, page 1019.
Bearing inside diameter is unsupported in this area ③.
- 6) Sizes d > 460 mm available by agreement.
- 7) Valid for adapted adjacent construction.

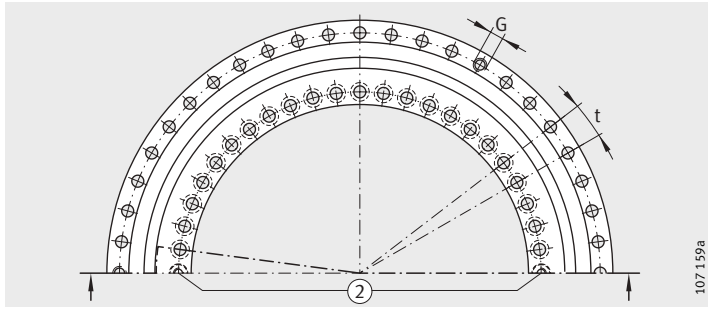

Hole pattern
① Retaining screws

Outer ring		Pitch t ¹⁾		Screw tightening torque	Basic load ratings		Limiting speed ⁷⁾	Bearing frictional torque	Axial rigidity ³⁾	Radial rigidity ³⁾	Tilting rigidity ³⁾	
Fixing holes		Threaded extraction hole			axial							
d ₃	Quantity ⁴⁾	G	Quantity		QuantityXt	M _A ²⁾						dyn. C _a
					Nm	N	N	min ⁻¹	Nm	kN/μm	kN/μm	kNm/mrad
5,6	15	M5	3	18X20°	8,5	71 000	265 000	2 800	1,6	1,2	0,35	3,6
7	21	M8	3	24X15°	14	76 000	315 000	2 400	2	1,5	0,4	5,5
7	33	M8	3	36X10°	14	81 000	380 000	2 000	3	1,7	0,5	7,8
7	45	M8	3	48X 7,5°	14	121 000	610 000	1 600	4,5	2,5	0,7	17,5
9,3	33	M12	3	36X10°	34	162 000	920 000	1 200	7,5	3,2	0,9	40
9,3	33	M12	3	36X10°	34	172 000	1 110 000	1 000	11	4	1	60
9,3	45	M12	3	48X 7,5°	34	241 000	1 580 000	800	16	4,5	1,3	100
9,3	45	M12	3	48X 7,5°	34	255 000	1 860 000	700	21	5,3	1,6	175

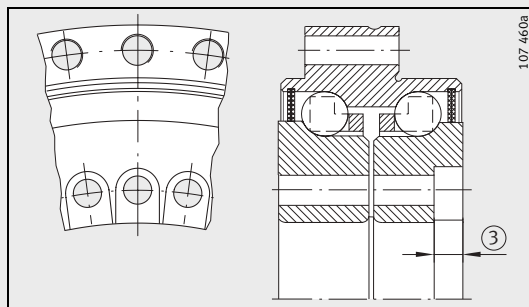

Screw counterbore open
Bearing inside diameter unsupported in area ③



FAG

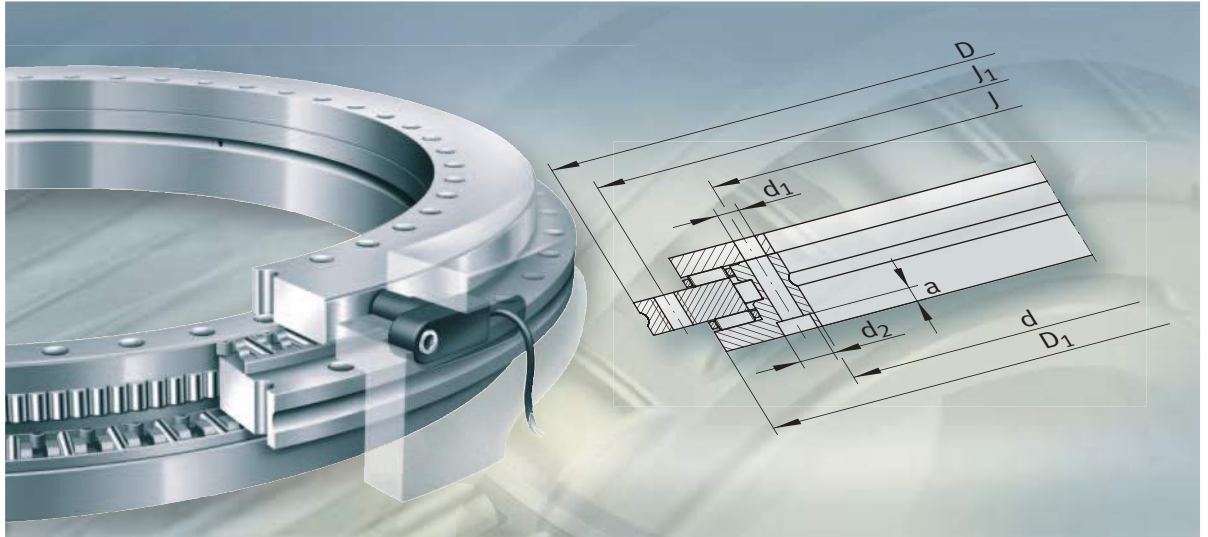

**Axial/radial bearings
with integral measuring system**

Axial/radial bearings with integral measuring system

	Page
Product overview	
Axial/radial bearings with integral measuring system.....	1022
Features	
Advantages of the angular measuring system.....	1023
Axial/radial bearings with integral measuring system.....	1024
MEKO/U electronic measuring system	1024
Measurement accuracy	1025
Technical Product Information on axial/radial bearings with integral measuring system	1026



Product overview Axial/radial bearings with integral measuring system

Axial/radial bearings
With magnetic dimensional scale

YRTM

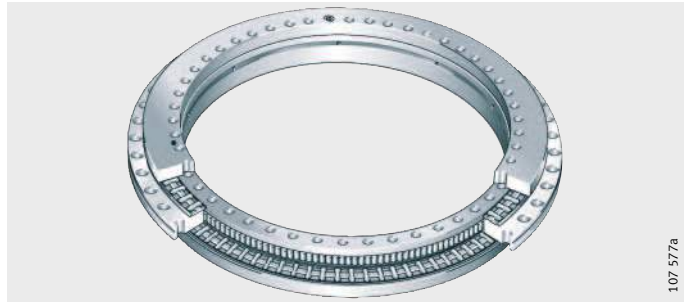

107_577a

MEKO/U
electronic measuring system
Measuring heads

MEKO/U



107_581

Electronic evaluation system

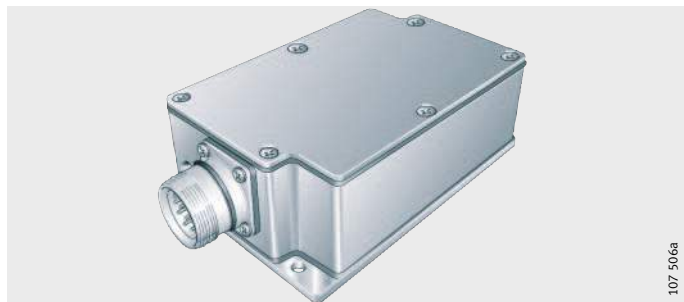

107_506a

Axial/radial bearings with integral measuring system

Features

Axial/radial bearings with integral measuring system comprise:

- an axial/radial bearing YRTM with a dimensional scale and a MEKO/U electronic measuring system. The electronic measuring system consists of two measuring heads, a set of shims and an electronic evaluation system.

Bearings of series YRTM correspond in mechanical terms to axial bearings YRT but are additionally fitted with a magnetic dimensional scale. The measuring system can measure angles to an accuracy of a few angular seconds by non-contact, magneto-resistive means.

For the mechanical part of axial/radial bearings YRTM, please refer to the information from page 995 to page 1011.

Advantages of the angular measuring system

The measuring system, *Figure 1*:

- operates by non-contact means and is therefore not subject to wear
- carries out measurement irrespective of tilting and position
- has automatically self-adjusting electronics
- has a self-centring function
- is unaffected by lubricants
- is easy to fit, the measuring heads are easily adjustable, there is no need for alignment of the bearing and a separate measuring system
- requires no additional parts
 - the dimensional scale and measuring heads are integrated in the bearing and adjacent construction respectively
 - the resulting space saved can be used for the machining area of the machine
- does not give any problems relating to supply cables. The cables can be laid within the adjacent construction directly through the large bearing bore
- gives savings on design envelope size and costs due to the compact, integrated design requiring fewer components.



- ① Magnetic scale
- ② Magnetic field lines
- ③ Measuring head with magneto-resistive sensor
- ④ Electronic evaluation system
- ⑤ Analogue signals at output

Figure 1
Measurement principle

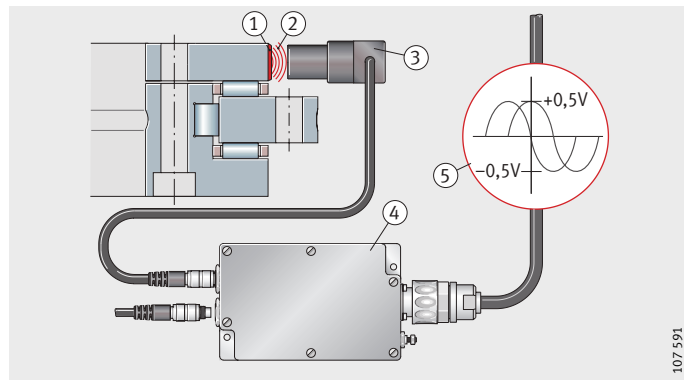

Axial/radial bearings with integral measuring system

Axial/radial bearings with integral measuring system

Dimensional scale

The dimensional scale is applied without seams or joins to the outside diameter of the shaft locating washer. Magnetic poles are present as angle references, *Figure 2* on the magnetisable, electroplated coating at a pitch of 250 μm .

The angular position is measured incrementally, i.e. by counting the individual increments. For a fixed datum point for the angular position after the machine is switched on, an additional reference mark is therefore also required.

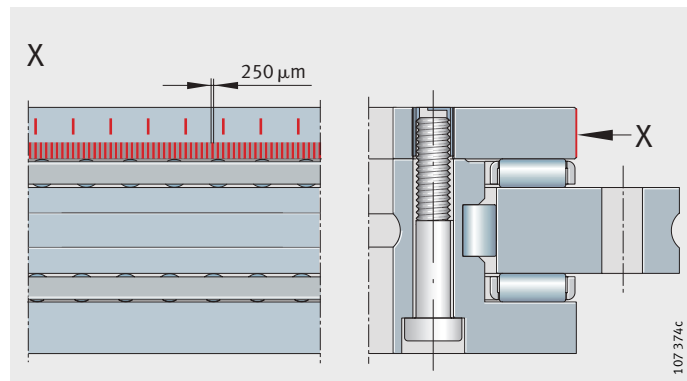

Figure 2
Dimensional scale

Reference marks

The system has pitch-coded reference marks in order to quickly create the absolute datum point. Every 15°, reference marks are applied with defined different pitches, so that the absolute datum point is achieved by passing over two adjacent reference marks (maximum 30°).

MEKO/U electronic measuring system

Measuring heads with magneto-resistive sensors

The two measuring heads are designed for optimum use of space. They are fixed in a slot in the adjacent construction by means of a fixing screw.

The small magnetic fields are detected as a result of the magneto-resistive effect (MR effect). Compared with magnetic heads, the MR sensors allow static measurement of magnetic fields, i.e. electrical signals are derived without movement, in contrast to magnetic heads.

The resistance layer of the MR sensors is designed such that the resistance changes when a magnetic field is perpendicular to the current flow.

When the magnetic pitch moves past the MR sensor, two sine wave signals with a phase offset of 90° are generated with a period length of 500 μm .

Electronic evaluation system	<p>The electronic evaluation system operates with the aid of a digital signal processor (DSP).</p> <p>The input signals are digitised by an analogue/digital converter. The high performance processor (DSP) automatically compares the sensor signals and calculates the effective angular value from the sensor signals by means of vector addition. Correction is carried out, for example, on the offset of the analogue signals. A digital/analogue converter generates synthetic analogue signals as a $1 V_{SS}$ value.</p> <p>The electronic evaluation system can be positioned at any location or within the adjacent construction. It is connected to the controller by means of a conventional 12-pin extension cable.</p> <p>The connections for transmitting the voltage signals from the electronic evaluation system to the electronic post-processor can be up to 100 m long.</p>
Cable for signal transmission	<p>Each measuring head is fitted with a 2 m, 2,5 m or 3 m long cable with a plug.</p> <p>The shielded cables of the measuring system components are made from polyurethane (PUR) and, in accordance with VDO 0672, resistant to oil, hydrolysis and microbes.</p> <p>The cables are suitable for fixed laying free from forces or torsion. The minimum bending radius $R \geq 40$ mm must be observed. For other requirements, please contact us.</p>
Plug connectors	<p>INA plug connectors are robust and designed for use in industrial environments. When connected, they conform to protection grade IP 65 (EN 60 529).</p> <p>The large sheathed areas of the plugs ensure effective shielding.</p>
Measurement accuracy	<p>The more accurate the angular measurement, the more accurately a rotary axis can be positioned. The accuracy of angular measurement is essentially determined by:</p> <ol style="list-style-type: none"> ① the quality of the dimensional scale ② the quality of scanning ③ the quality of the electronic evaluation system ④ the eccentricity of the dimensional scale to the bearing raceway system ⑤ the runout deviation of the bearing arrangement ⑥ the elasticity of the measurement system shaft and its linkage to the shaft to be measured ⑦ the elasticity of the stator shaft and shaft coupling. <p>For the measuring system YRTM, only points ① to ③ are relevant. The eccentricity in point ④ is completely eliminated by the diametrically opposed arrangement of the MR sensors. Points ⑤ to ⑦ play only a very minor role in the INA measuring system.</p>



Axial/radial bearings with integral measuring system

Positional deviations

Positional deviations within a revolution are the absolute measurement errors over one revolution of the system (measured at +20 °C ambient temperature)

■ YRTM150 $\cong \pm 6''$

■ YRTM180 $\cong \pm 5''$

■ YRTM200, YRTM260, YRTM325, YRTM395, YRTM460 $\cong \pm 3''$.

Since the dimensional scale is directly connected, i.e. without any compensation elements, to the rolling bearing, deflections in the bearing raceway system due to machining forces can affect the measurement result. This effect is eliminated by the diametrically opposed arrangement of the measuring heads in the electronic evaluation system.

Measurement record

Each INA measuring system is supplied with an accuracy measurement record, *Figure 3*.

The accuracy is measured on the coded washer of the YRTM bearing when the coding is applied and is documented.

The measurement trace shows the pitch error of the coding.

- ① Measurement travel in degrees
- ② Deviation in angular seconds

Figure 3

Excerpt from a measurement trace –
example
YRTM 395 – S.Nr. 03/09/004

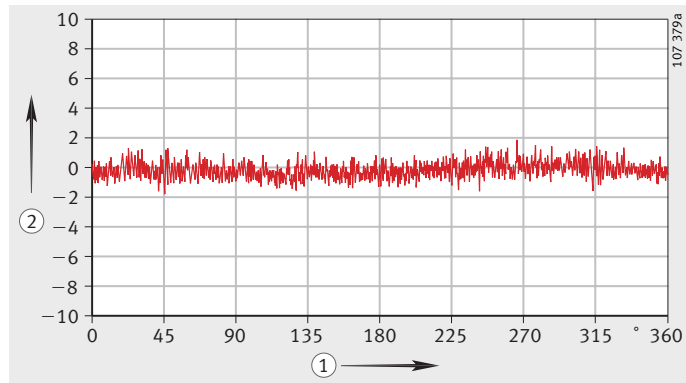

Technical Product Information on axial/radial bearings with integral measuring system

Comprehensive information on axial/radial bearings with an integral measuring system is given in TPI 120, High precision bearings for combined loads. This publication is available on request.



Radial insert ball bearings Housed bearing units



Radial insert ball bearings Housed bearing units

Radial insert ball bearings 1030

INA radial insert ball bearings are ready-to-fit rolling bearings for the design of particularly economical bearing arrangements. These robust machine elements are available in numerous designs that differ essentially in the outside surface of the outer ring, the method of location on the shaft and the sealing arrangement.

Radial insert ball bearings with a spherical outer ring, fitted in housings with a concave bore, can compensate for static misalignment of the shaft. They can be relubricated if necessary and are particularly easy to fit due to the special location methods. Operation even under difficult operating conditions is ensured by seals of a three-piece design that are matched to the application. The classic areas of application for these bearings include the agricultural, construction and mining sectors, conveying equipment, textile, paper and woodworking machinery as well as machines for the filling, timber and packaging industries.

Housing units 1080

with cast iron housings
with sheet steel housings

Housing units comprise INA cast iron or sheet steel housings with a concave bore in which INA insert bearings are mounted. These units are matched to each other and are available as plummer block, flanged and take-up housing units. Due to the wide range of housing designs, the right solution can be found for any specific application. The areas of application of the units correspond to those of the insert bearings.

Cast iron housings are single-piece units that can support high loads. Sheet steel housings are two-piece units that are used where the priority is not the load carrying capacity of the housing but the low mass of the unit.

Depending on the series, INA take-up housing units have integral fixing eyes with holes, slots and guide surfaces. They can therefore be moved in an axial direction or swivelled in a radial direction.

Roller chain idler sprocket units Idler pulley units 1172

Roller chain idler sprocket units are guidance and return units for roller bush chains and roller chains. They can compensate for chain stretch resulting from operation and give smoother running under high loads and speeds.

Idler pulley units are tensioning systems for belt drives and idler pulleys. They are suitable for V-belts, flat or round belts, steel and hemp cables. Idler pulley units increase the wrap angle, compensate for belt stretch resulting from operation, allow shorter centre distances and reduce belt wear.

Product range – selection

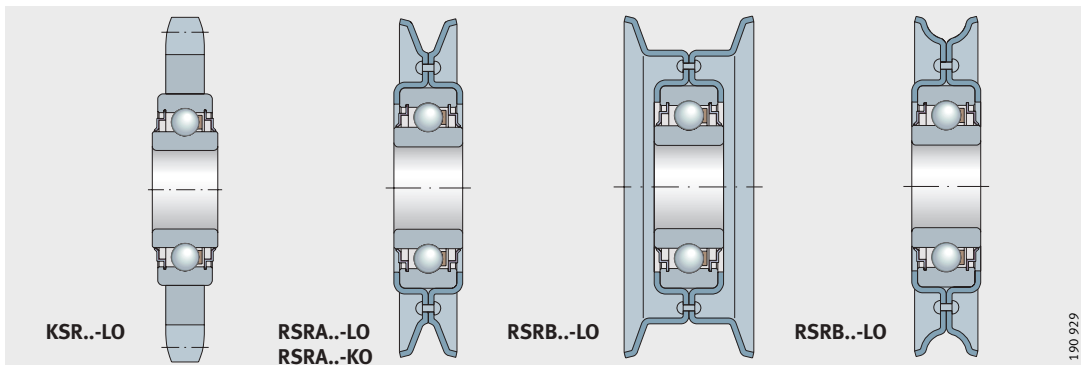
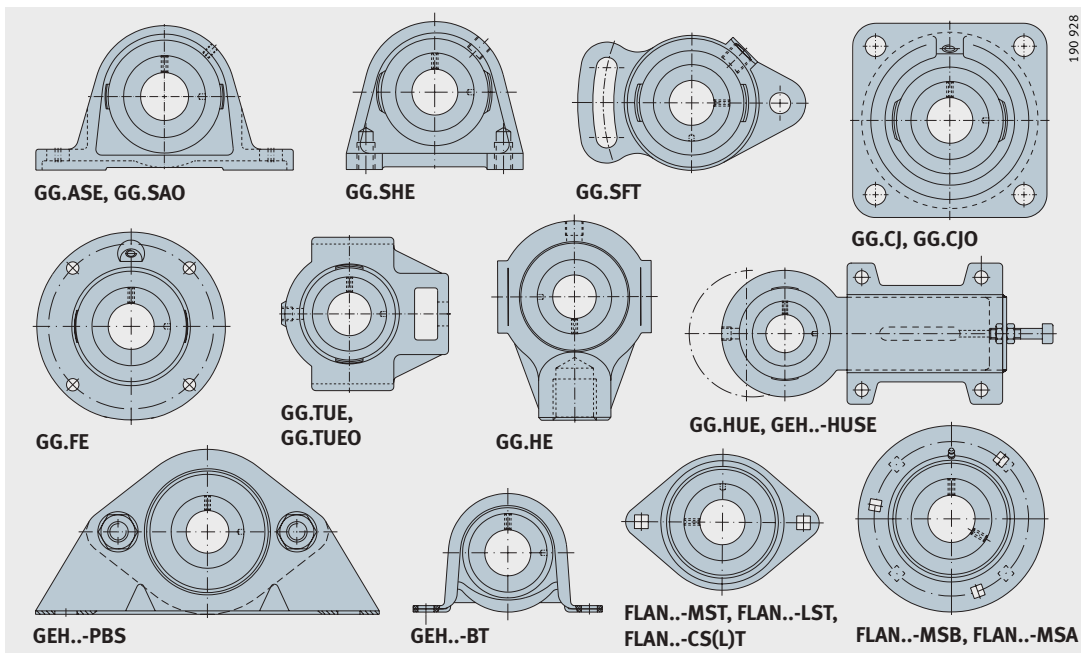
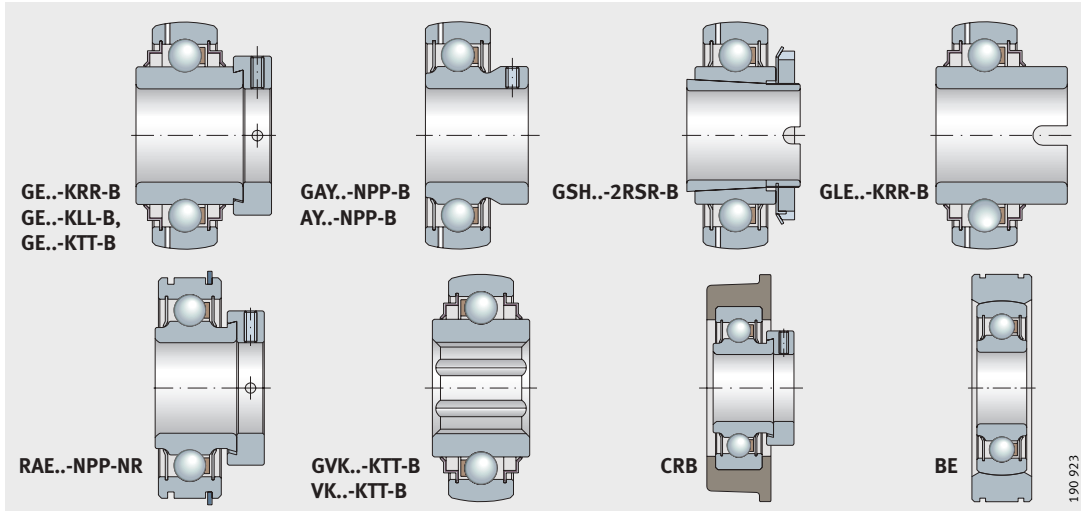

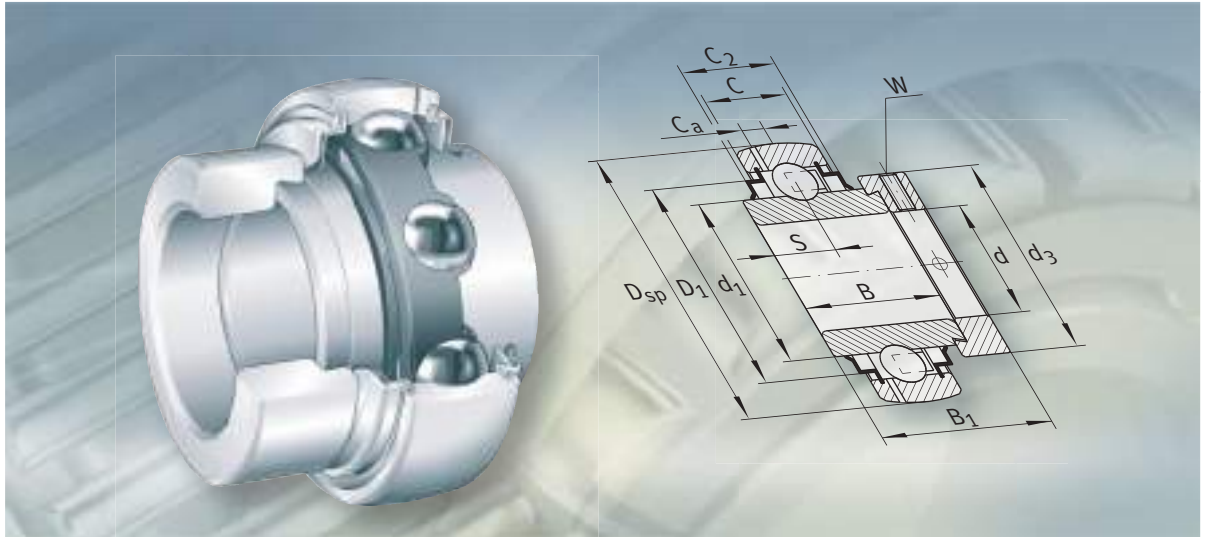

Radial insert ball bearings

Radial insert ball bearings

	Page
Product overview	Radial insert ball bearings..... 1032
Features	Radial insert ball bearings..... 1036
	Radial insert ball bearings with eccentric locking collar 1037
	Radial insert ball bearings with grub screws in inner ring..... 1038
	Radial insert ball bearings with integral adapter sleeve 1039
	Radial insert ball bearings with drive slot 1040
	Self-aligning deep groove ball bearings..... 1041
	Deep groove ball bearings with extended inner ring..... 1042
	Radial insert ball bearings with steel aligning ring 1043
	Radial insert ball bearings with eccentric locking collar, cylindrical outer ring and slots in outer ring 1043
	Radial insert ball bearings with rubber interliner 1044
	Suffixes 1044
	Sealing – seal types 1045
	Features of radial insert ball bearings – comparison..... 1046
Design and safety guidelines	Compensation of misalignments 1048
	Axial load carrying capacity of radial insert ball bearings 1048
	Speed limits for radial insert ball bearings – guide values 1049
	Shaft tolerances for radial insert ball bearings – recommendations 1049
Accuracy	Standard tolerances of radial insert ball bearings..... 1050
	Radial internal clearance of radial insert ball bearings..... 1050
Dimension tables	Radial insert ball bearings with eccentric locking collar, spherical outer ring 1052
	Radial insert ball bearings with grub screws in inner ring..... 1060
	Radial insert ball bearings with integral adapter sleeve 1064
	Radial insert ball bearings with drive slot 1065
	Radial insert ball bearings with eccentric locking collar, cylindrical outer ring..... 1066
	Inch size radial insert ball bearings 1068
	Radial insert ball bearings with rubber interliner 1072
	Radial insert ball bearings with steel aligning ring 1074
	Deep groove ball bearings with extended inner ring..... 1075
	Self-aligning deep groove ball bearings with square or hexagonal bore..... 1076
	Self-aligning deep groove ball bearings with bore for fit..... 1078



Product overview Radial insert ball bearings

With eccentric locking collar
Spherical outer ring

Features: see page 1037

**GRAE..-NPP-B, RAE..-NPP-B,
RALE..-NPP-B**

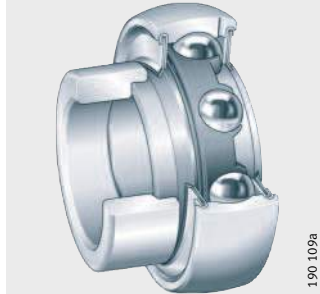

**GE..-KRR-B, GNE..-KRR-B,
E..-KRR-B, NE..-KRR-B**



GE..-KTT-B



GE..-KLL-B

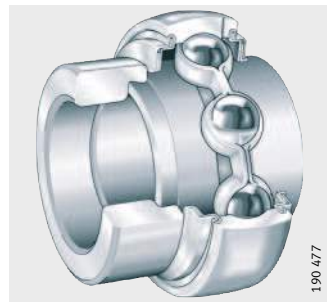

GE..-KRR-B-2C

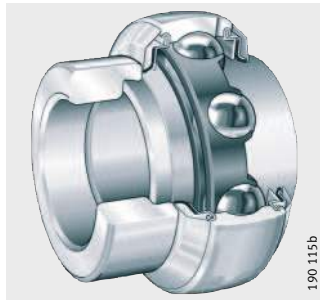

**With grub screws
in inner ring**
Spherical outer ring

Features: see page 1038

GAY..-NPP-B, AY..-NPP-B



GYE..-KRR-B



With integral adapter sleeve

Spherical outer ring

Features: see page 1039

GSH..-2RSR-B



With drive slot

Spherical outer ring

Features: see page 1040

GLE..-KRR-B



**Self-aligning
deep groove ball bearings**

Spherical outer ring
With fit

Features: see page 1041

2..-NPP-B



Spherical outer ring
With square or hexagonal bore

Features: see page 1041

GVK..-KTT-B, VK..-KTT-B



SK..-KRR-B



Product overview Radial insert ball bearings

Deep groove ball bearings with extended inner ring

Cylindrical outer ring

Features: see page 1042

2..-KRR, 2..-KRR-AH



With steel aligning ring

Cylindrical outer ring

Features: see page 1043

PE

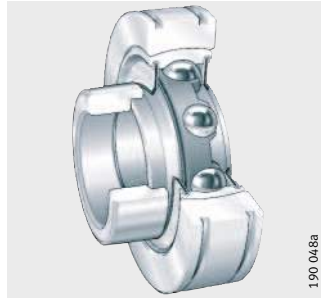

BE

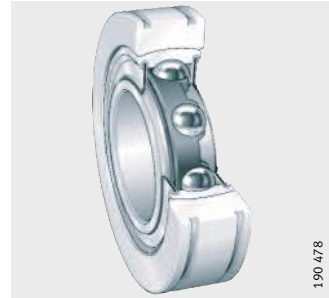

With eccentric locking collar

Cylindrical outer ring

Features: see page 1037

RAE..-NPP, RALE..-NPP



With eccentric locking collar

Cylindrical outer ring
Two snap rings on outer ring

Features: see page 1043

RAE..-NPP-NR

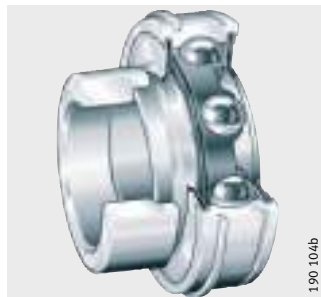

With rubber interliner

Features: see page 1044

RABRA, RABRB

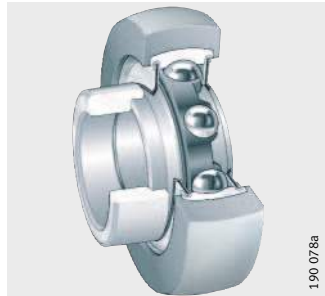

RCRA, RCRB



CRB

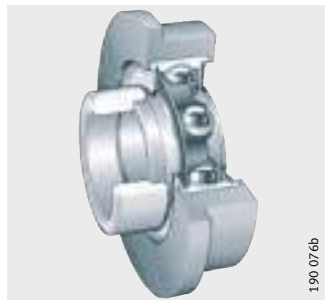

RCSMA, RCSMB



Inch size radial insert ball bearings

Spherical or cylindrical outer ring

Features: see page 1037 and page 1038

**GRA...NPP-B-AS2/V,
RA...NPP-B**

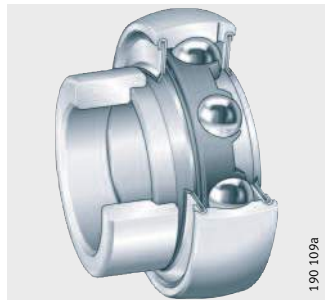

G...KRR-B-AS2/V



GY...KRR-B-AS2/V



RA...NPP, RAL...NPP



Radial insert ball bearings

Features Radial insert ball bearings are single row, ready-to-fit units comprising a solid outer ring, an inner ring extended on one or both sides, cages made from plastic or sheet steel and seals of type P, R, L or T. Bearings with an inner ring extended on both sides undergo less tilting of the inner ring and therefore run more smoothly.

The outer ring has a spherical or cylindrical outside surface. In combination with an INA housing matched to the design, bearings with a spherical outer ring can compensate for misalignment of the shaft; see Compensation of misalignments, page 1048.

With only a few exceptions, radial insert ball bearings can be relubricated. For this purpose, they have two lubrication holes in the outer ring offset by 180°.

Radial insert ball bearings are particularly easy to fit and are suitable for drawn shafts of grade h6 to h9. They are located on the shaft by means of eccentric locking collars, grub screws in the inner ring, adapter sleeves, drive slots or fit.

Caution! The features of the series are presented in detail in the product overview on pages 1046 and 1047. Please take these into consideration.

Inch size designs Some series with eccentric locking collar or grub screws in the inner ring are also available with inch size bore dimensions, see dimension tables, page 1068 to page 1070.

Corrosion-resistant radial insert ball bearings For corrosion-resistant bearing arrangements and for applications in the food and drink industry, bearings are available with Corrotect® plating and the suffix FA125 as well as in the VA design using corrosion-resistant materials.

Corrotect® plating The special INA plating Corrotect® is an economical alternative to traditional forms of corrosion protection for radial insert ball bearings. The thickness of the plating is between 0,5 µm and 3 µm.

- Advantages of the Corrotect® plating**
- All-round rust protection including machined surfaces on chamfers and radii
 - Long-term prevention of rust penetration beneath seals
 - Small bright spots are protected against corrosion by the cathodic protection mechanism
 - Anti-corrosion protection allows a significantly longer operating life compared to unplated parts
 - Unplated bearings and housings are fully interchangeable with the plated versions of the same design
 - Bearings and housings made from corrosion-resistant rolling bearing steel are often no longer required.

In radial insert ball bearings of variant VA, the bearing rings and rolling elements are made from corrosion-resistant, high alloy rolling bearing steel with an increased chromium and molybdenum content.

Corrosion-resistant radial insert ball bearings are suitable where moisture, contaminated water, salt spray mist or weakly alkaline and weakly acidic cleaning agents are present.

For information on Corrotect® see also section Anti-corrosion protection, page 104.

Radial insert ball bearings for high and low temperatures

At high temperatures, rolling bearings undergo an increase in volume that can be attributed to a change in the material micro-structure. Furthermore – depending on the location of the heat source – there can be a significant temperature difference between the inner and outer ring.

The radial insert ball bearings have cages made from metal or a high temperature plastic, increased radial internal clearance, lubricants with improved thermal resistance and special seals.

These bearings have the suffix FA164 or FA101. Series GLE...KRR-B and GE...KLL-B also have an extended temperature range.

Radial insert ball bearings with eccentric locking collar

These “classic” INA radial insert ball bearings are located on the shaft by means of a locking collar, *Figure 1*. They are particularly suitable for bearing arrangements with a constant direction of rotation or, under low speed and load, for an alternating direction of rotation.

The locking collar is preferably tightened in the direction of rotation and secured by means of a grub screw. This location method prevents damage to the shaft and can be easily loosened again.

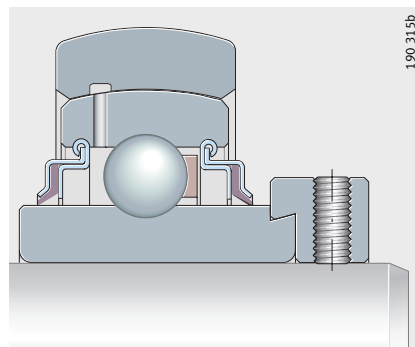

GE...KRR-B

Figure 1
Location using eccentric locking collar

Sealing/lubrication

The radial insert ball bearings are fitted with P, R, L or T type seals and, with the exception of a few series, can be relubricated. In series GE...KRR-B-2C, the R seals are fitted with Corrotect® plated flinger shields to protect against mechanical damage.



Corrosion-resistant radial insert ball bearings

Several series are also available in a corrosion-resistant design. These bearings have the suffix FA125.

Inner rings up to d = 60 mm, as well as locking collars in general, are plated with Corrotect® and are thus protected against fretting corrosion; the exception is series RALE...NPP(-B).

Radial insert ball bearings for high and low temperatures

Bearings for high and low temperatures have the suffix FA164 or FA101.

Cylindrical outer ring

In addition to the bearings with a spherical outer ring, there are also the following series with a cylindrical outer ring: RAE...NPP, RALE...NPP, E...KRR and E...KLL.

Inch size designs

The series GRA...NPP-B-AS2/V, RA...NPP-B, G...KRR-B-AS2/V, RA...NPP, RAL...NPP have inch size bore dimensions, see dimension tables, page 1068 to page 1070.

Radial insert ball bearings

Radial insert ball bearings with grub screws in the inner ring

In these insert bearings, the inner ring is located on the shaft, *Figure 2* by means of two grub screws offset by 120°. This location method is suitable for bearing arrangements with a constant direction of rotation or, under low speed and load, for an alternating direction of rotation.

The grub screws are self-retaining and have a fine pitch thread with cup point for secure location of the bearings.

GYE..-KRR-B

Figure 2

Location using grub screws in the inner ring

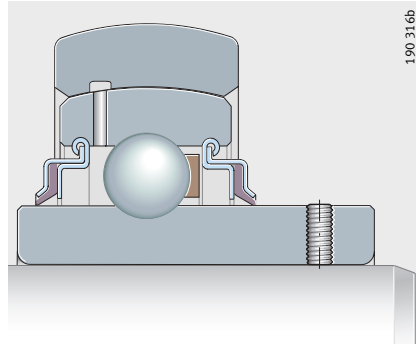

Sealing/lubrication

The radial insert ball bearings are fitted with P or R type seals and, with the exception of one series, can be relubricated.

Corrosion-resistant radial insert ball bearings

These bearings have the suffix VA. The VA design is sealed on both sides with RSR seals and has additional flinger shields made from corrosion-resistant steel.

Radial insert ball bearings for high and low temperatures

Some radial insert ball bearings are also available for higher temperatures. These bearings have the suffix FA164.

Inch size designs

Series GY..-KRR-B-AS2/V has an inch size bore, see dimension tables, page 1068 to page 1070.

Radial insert ball bearings with integral adapter sleeve

In this series, the inner ring is located on the shaft by an adapter sleeve with a locknut and a tab washer, *Figure 3*.

The adapter sleeve and locknut give concentric, force locking location of the bearing inner ring on the shaft.

As a result, the speeds that can be achieved are the same as with deep groove ball bearings. These bearings also give quieter running than normal radial insert ball bearings. The adapter sleeve, locknut and tab washer are all zinc plated.

Due to the integral adapter sleeve, the bearings have the same radial dimensions and basic load ratings as radial insert ball bearings with an eccentric locking collar or with grub screws in the inner ring and are interchangeable with these bearings.

GSH...2RSR-B

Figure 3

Location using adapter sleeve and locknut

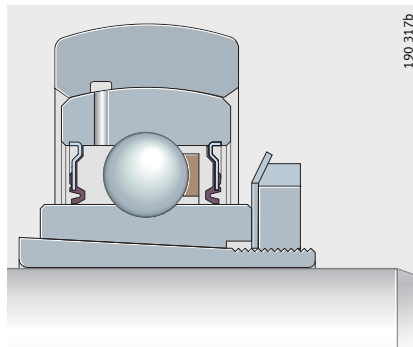

Sealing/lubrication

The bearings are sealed with RSR seals and can be lubricated.



Radial insert ball bearings

Radial insert ball bearings with drive slot

Radial insert ball bearings with a drive slot in the inner ring are non-locating bearings with good high temperature characteristics, *Figure 4*. Non-locating bearings are used at low speeds and loads to compensate for thermal elongation of the shaft.

Due to the slot, they are easy to locate in a radial direction. Rotation is prevented by a drive pin on the shaft or a set collar with a pin. The non-locating bearings are suitable for drawn shafts up to grade h7.

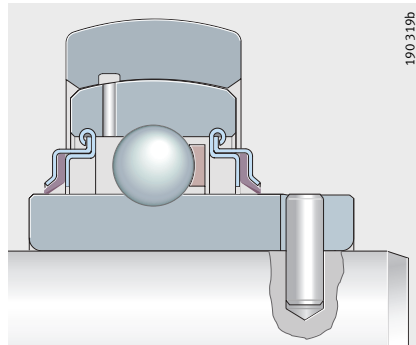

GLE..KRR-B

Figure 4
Location using drive slot

Anti-corrosion protection

Up to a bore diameter of 60 mm, the inner ring is plated with Corrotect® and is thus protected against fretting corrosion.

Sealing/lubrication

The bearings have R type seals with Teflon seal lips and can be lubricated.

Self-aligning deep groove ball bearings

Self-aligning deep groove ball bearings are available with a cylindrical bore for a fit seat, *Figure 5* or with a reamed square or hexagonal bore, *Figure 6*.

With fit

Bearings with a fit seat on the shaft allow speeds equivalent to those of standard ball bearings, are suitable for bearing arrangements with an alternating direction of rotation and offer smooth running.

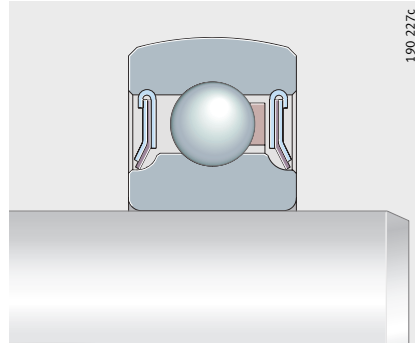

2...NPP-B

Figure 5
Self-aligning deep groove ball bearings

Seals

The bearings are sealed on both sides using P type seals with a vulcanised seal lip or three-piece designs.

Caution!

For self-aligning deep groove ball bearings with a fit seat, the fit data for ball bearings apply.

With square or hexagonal bore

Bearings with a profiled bore are used where shafts must transmit very high torques and this is only possible using square or hexagonal shafts, *Figure 6*. Rotation is prevented by the geometrical locking effect.

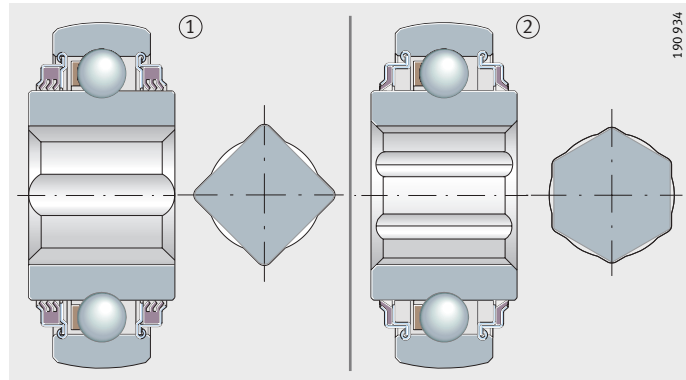

VK...KTT-B
SK...KRR-B

Figure 6
① Square bore
② Hexagonal bore

Anti-corrosion protection

The bearings are plated with Corrotect®.

Sealing/lubrication

Self-aligning deep groove ball bearings are sealed using R or T type seals. The bearings are greased to their maximum, some designs can be relubricated.

Radial insert ball bearings

Deep groove ball bearings with extended inner ring

These bearings have a cylindrical outer ring and are fitted in cylindrical bores, *Figure 7*. The inner ring is extended on both sides and is located on the shaft using a location fit. Due to the extended inner ring, additional axial spacer rings are not required.

The concentric seat allows speeds equivalent to those of standard ball bearings, while the load can be either constant or alternating. Smooth running is also achieved.

The inner ring bore tolerance corresponds to tolerance class PN in accordance with DIN 620.

2..-KRR
2..-KRR-AH

Figure 7

Deep groove ball bearings with extended inner ring

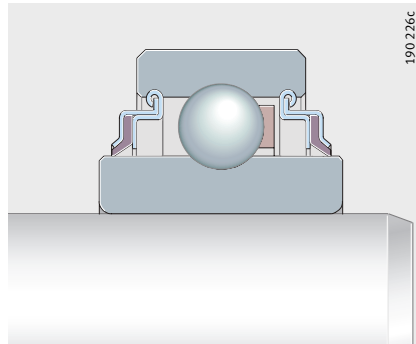

Sealing/lubrication

The bearings are sealed on both sides using R type seals. The sheet steel washers extended outwards and angled downwards form a large grease reservoir.

Radial insert ball bearings with steel aligning ring

These bearings are based on radial insert ball bearings with an eccentric locking collar or on self-aligning deep groove ball bearings, but additionally have an axially split outer ring as an aligning ring, *Figure 8*. They are mounted in cylindrical bores and can compensate for static misalignment of the shaft up to $\pm 5^\circ$.

Due to the annular slots in the outer ring, they are highly suitable for sheet metal constructions. In this case, they are axially located using snap rings to DIN 5 417.

In series PE, the inner ring is located on the shaft using a locking collar, in series BE by a location fit.

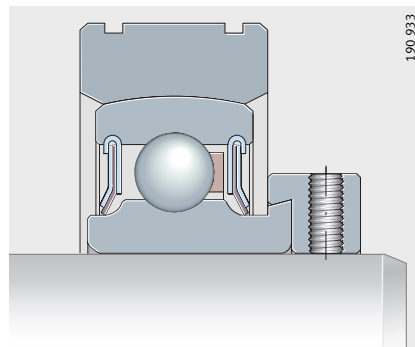

PE

Figure 8
Radial insert ball bearings with steel aligning ring

Anti-corrosion protection

The aligning ring is plated with Corrotect® and is thus protected against fretting corrosion. In series PE, the inner ring and locking collar are also plated.

Sealing/lubrication

The bearings are sealed on both sides using P type seals. Radial insert ball bearings with an aligning ring cannot be relubricated.

Caution!

The fit tolerances of the aligning rings are those of the deep groove ball bearings. Select the fit for the shaft and housing such that the outer ring of the insert bearing can undergo self-alignment.

Radial insert ball bearings with eccentric locking collar, cylindrical outer ring and slots in outer ring

The basic design of series RAE...NPP-NR is a radial insert ball bearing with an eccentric locking collar and an inner ring extended on one side, *Figure 9*. The outer ring has a cylindrical outside surface and two slots to DIN 616. The bearings are fitted in cylindrical bores and axially located by easy-to-fit snap rings. The bearing is supplied with one snap ring to DIN 5 417 already fitted.



Sealing/lubrication

The bearings are sealed on both sides using P type seals. The insert bearings are greased and cannot be relubricated.

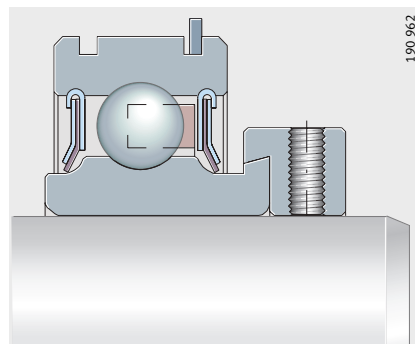

RAE...NPP-NR

Figure 9
Radial insert ball bearings with cylindrical outer ring and two slots in outer ring

Radial insert ball bearings

Radial insert ball bearings with rubber interliner

These radial insert ball bearings are located on the shaft using an eccentric locking collar. The outer ring is encased in a thick-walled NBR interliner, *Figure 10*.

The interliner absorbs vibrations and shocks and thus gives damping of running noises.

The interliners have a spherical or cylindrical outside surface.

For roll bearing arrangements, one series has a locating shoulder on the rubber ring.

CRB

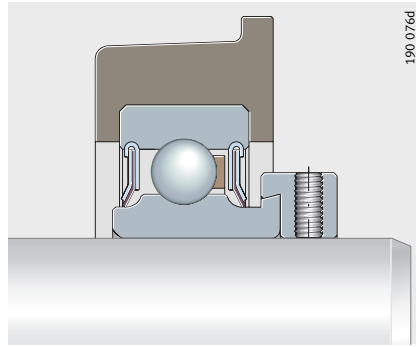

Figure 10

Radial insert ball bearings with rubber interliner

Anti-corrosion protection

The inner ring and locking collar are plated with Corrotect® and are thus protected against fretting corrosion; this excludes insert bearing series RALE..-NPP(-B).

Sealing/lubrication

The radial insert ball bearings are sealed on both sides using P type seals. Bearings with rubber interliners cannot be lubricated.

Caution!

Note the tube and housing diameters for radial insert ball bearings with rubber interliner:

- CRB, tube inside diameter D –0,6 to 1,6
- RABR, RCR, RCSM, housing diameter D –0,25 to 0,35.

Suffixes

Suffixes for the available radial insert ball bearing designs: see table.

Available designs

Suffix	Description
AS2/V	Bearing outer ring with 2 lubrication holes in offset planes
B	Bearing with spherical outer ring
2C	Flinger shields on both sides
FA101	High/low temperature design –40 °C to +150 °C
FA106	Bearing subjected to special noise testing
FA107	Bearing with lubrication holes on the locating side
FA125	With Corrotect® plating, protected against corrosion
FA164	High temperature design up to +250 °C
KRR	Lip seals on both sides (R type seal)
KLL	Labyrinth seals on both sides (L type seal)
KTT	Triple lip seals on both sides (T type seal)
NR	Slot and snap ring for insert bearings with cylindrical outer ring
NPP	Lip seals on both sides (P type seal)
OSE	Bearing without locating element (e.g. eccentric locking collar)
2RSR	Lip seals on both sides (vulcanised)
VA	Corrosion-resistant design made from high alloy rolling bearing steel

Seals Seals for radial insert ball bearings are of a three-piece design. This concept offers, due to the rigidly rolled-in sheet steel washer, optimum seating in the bearing as well as concentric alignment of the seal lip to the inner ring.

Seal types

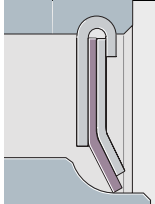
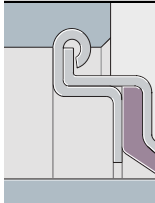
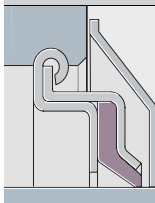
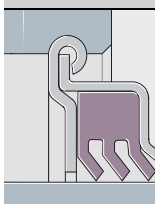
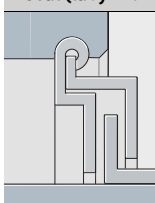
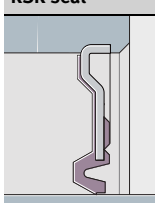
P seal	
	<p>190 308a</p> <p>Two zinc-plated sheet steel washers with intermediate NBR part, seal lip axially preloaded.</p> <p>In order to protect the seal lip from mechanical damage, the outer sheet steel washer extends a considerable distance down towards the bearing inner ring.</p> <p>Used in narrow radial insert ball bearings with inner ring extended on one side.</p>
R seal	
	<p>190 309b</p> <p>Two zinc-plated sheet steel washers extended outwards and angled downwards with intermediate NBR part and radially preloaded seal lip. Better protection against mechanical damage.</p> <p>Substantial grease reservoir due to the space between the extended and angled sheet steel washers.</p> <p>Used in radial insert ball bearings with inner ring extended on both sides.</p>
R seal with C shield	
	<p>190 318a</p> <p>As R seal, but with outer flinger shield with anti-corrosion protection.</p> <p>Additional sealing action without restriction on speed and with additional protection against mechanical damage.</p>
T seal	
	<p>190 310c</p> <p>Two zinc-plated sheet steel washers with intermediate NBR part and three radially preloaded seal lips for heavily contaminated conditions.</p> <p>For better protection of the seal lip against mechanical damage, the outer sheet steel washer is angled outwards.</p> <p>Lower speeds due to higher friction.</p>
L seal (labyrinth seal)	
	<p>190 311b</p> <p>Two zinc-plated sheet steel washers extended outwards in the outer ring with an intermediate sheet steel L-section ring pressed onto the inner ring.</p> <p>Substantial grease reservoir due to the space between the extended and angled sheet steel washers.</p> <p>Used in radial insert ball bearings with inner ring extended on both sides. For increased temperatures and lower friction.</p>
RSR seal	
	<p>190 314d</p> <p>Single-piece, zinc-plated sheet steel washer with moulded, radially preloaded NBR seal lip.</p> <p>Used in radial insert ball bearings with integral adapter sleeve.</p>



Radial insert ball bearings

Features of radial insert ball bearings – comparison of series

Series	For shaft diameters from ... to ...	Compensation of misalignment	Internal clearance		
GRAE..-NPP-B	12 mm – 60 mm	yes	C3		
GRAE..-NPP-B-FA125.5	20 mm – 60 mm				
GRA..-NPP-B-AS2/V	$5/8$ inch – $1\ 3/4$ inch				
RAE..-NPP-B	12 mm – 50 mm				
RA..-NPP-B	$3/4$ inch – $1\ 1/2$ inch				
RALE..-NPP-B	20 mm – 30 mm				
GE..-KRR-B	17 mm – 120 mm				
GE..-KRR-B-FA125.5	20 mm – 50 mm				
GE..-KRR-B-FA164	17 mm – 90 mm			C5	
GE..-KRR-B-FA101	20 mm – 120 mm			C4	
G1..-KRR-B-AS2/V	$1\ 5/16$ inch – $2\ 15/16$ inch			C3	
GE..-KRR-B-2C	25 mm – 40 mm				
E..-KRR-B	25 mm – 40 mm				
GNE..-KRR-B	30 mm – 100 mm				
GE..-KTT-B	20 mm – 80 mm				
GE..-KLL-B	20 mm – 50 mm			C5	
GYE..-KRR-B	12 mm – 90 mm			yes	C3
GY1..-KRR-B-AS2/V	$3/4$ inch – 2 inch				
GYE..-KRR-B-VA	12 mm – 40 mm				
GAY..-NPP-B	12 mm – 60 mm				
GAY..-NPP-B-FA164	12 mm, 15 mm	C5			
AY..-NPP-B	12 mm – 30 mm	C3			
GSH..-2RSR-B	20 mm – 50 mm	yes	C4		
GLE..-KRR-B	20 mm – 70 mm	yes	C4		
2..-NPP-B	12 mm – 50 mm	yes	CN		
GVK..-KTT-B	25,4 mm – 40,5 mm	yes	C3		
VK..-KTT-B	25,4 mm				
SK..-KRR-B	17 mm – 31,8 mm	yes	C3		
RABRA	30 mm	yes	C3		
RABRB	12 mm – 50 mm				
PE	20 mm – 40 mm				
BE	20 mm – 40 mm	yes	CN		
RAE..-NPP	12 mm – 60 mm	no	C3		
RA..-NPP	$5/8$ inch – $1\ 1/2$ inch				
RALE..-NPP	20 mm – 30 mm				
RAL..-NPP	$3/4$ inch				
RAE..-NPP-NR	20 mm – 40 mm				
E..-KRR	20 mm – 70 mm				
E..-KLL	20 mm – 50 mm				
RCRA	20 mm				
RCRB	25 mm				
CRB	20 mm – 35 mm				
RCSMA	30 mm				
RCSMB	15 mm – 25 mm				
2..-KRR(-AH)	13 mm – 60 mm			no	CN

Location	Sealing	Cage material	Greasing ¹⁾	Relubrication facility	Temperature ²⁾ °C	Comments	Dimension table		
Eccentric locking collar	P	PA66	GA13	yes	-20 to +120		1052		
			GA47				With anti-corrosion protection	1052	
			GA13	no			1068		
							1052		
							1068		
								Light series	1052
			R	PA66		GA47	yes		With anti-corrosion protection
	Steel	GA11			+150 to +250	Teflon [®] seal lip		1052	
	T	PAES	LO14	GA13	no	-40 to +150	Teflon [®] seal lip	1052	
						-20 to +120		1068	
							Flinger shields	1052	
								1052	
	L	Steel	LO86	GA13	yes		Heavy series	1054	
								1052	
Grub screws	R	PA66	GA13	yes	-20 to +120		1060		
								1068	
						RSR	VA steel		With anti-corrosion protection, flinger shields
	P	PA66	Steel	GA11	no	+150 to +250	Teflon [®] seal lip	1060	
								1060	
						PA66	GA13	-20 to +120	
Adapter sleeve	RSR	PA66	GA13	yes	-20 to +120		1064		
Drive slot	R	PAES	LO14	yes	-40 to +150	Teflon [®] seal lip	1065		
Fit	P	PA66	GA13	no	-20 to +120		1078		
Square bore	T	PA66	GA13	yes	-20 to +120	With anti-corrosion protection, with maximum grease filling	1076		
				no			1076		
Hexagonal bore	R	PA66	GA13	no	-20 to +120	With anti-corrosion protection, with maximum grease filling	1076		
Eccentric locking collar	P	PA66	GA13	no	-20 to +85	Light series	1072		
							1072		
							-20 to +120	Annular slots in aligning ring	1074
Fit	P	PA66	GA13	no	-20 to +120	Annular slots in aligning ring	1074		
Eccentric locking collar	P	PA66	GA13	no	-20 to +120		1066		
							1068		
							1066		
							1068		
							Two slots, one snap ring	1066	
							1066		
							1066		
	R	PA66	GA13	no	-20 to +85	Light series, lead chamfer	1072		
						Lead chamfer	1072		
						Abutment shoulder	1072		
						Light series	1072		
					1072				
Fit	R	PA66	GA13	no	-20 to +120		1075		



¹⁾ Precise information on greasing is given in the section Lubrication.

²⁾ **Caution! Recommended temperature. Regular relubrication if > +100 °C.**

Radial insert ball bearings

Design and safety guidelines Compensation of misalignments

Bearings with a spherical outer ring, fitted in housings with a concave bore, can compensate for static misalignment of the shaft, *Figure 11*:

- if relubrication is used, up to $\pm 2,5^\circ$
- if relubrication is not used, up to $\pm 5^\circ$.

Caution! The units must not be used to support swivelling or tumbling motion.

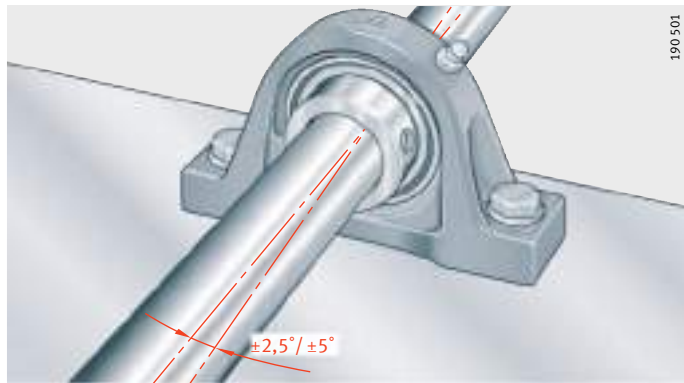

Figure 11
Compensation of static shaft misalignment

Axial load carrying capacity of radial insert ball bearings

The axial load carrying capacity F_a of radial insert ball bearings depends essentially on how they are located on the shaft. The load carrying capacity of the locating method is shown in *Figure 12*.

The precondition for this is that:

- the shaft design complies with the data in *Figure 12*
- the bearings are located using the specified tightening torque M_A .

Caution! For very high axial loads, the forces should be directed through a shoulder on the shaft. Maximum permissible axial load on the bearing: please contact us.

- ① Locking collar and adapter sleeve
 - ② Grub screw/hard, ground shafts
 - ③ Grub screw/soft shaft
- d = bearing bore diameter
 F_a = axial load carrying capacity of bearing

Figure 12
Axial load carrying capacity of locating method

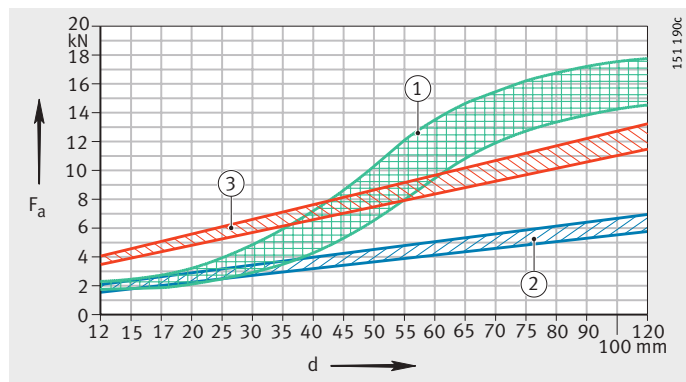

Speed limits for radial insert ball bearings – guide values

The speed limits are dependent on the load, the clearance between the bearing bore and shaft and the friction of the seals in bearings with contact seals.

Figure 13 gives guide values for the permissible speeds. For load ratios $C_r/P > 13$, the speeds can be increased. For these applications, please contact us.

For $C_r/P < 5$, location by means of a location fit is recommended.

Example of permissible speed calculation

Given:

■ Shaft tolerance	h6
■ Radial insert ball bearing	GRAE30-NPP-B
■ Basic dynamic load rating C_r	19 500 N
■ Load P	1300 N
■ Seals	P seals.

Required:

■ Load ratio	$C_r/P = 19\,500\text{ N}/1300\text{ N}$	$C_r/P > 13$
■ Permissible speed		$n \approx 4\,300\text{ min}^{-1}$, Figure 13.

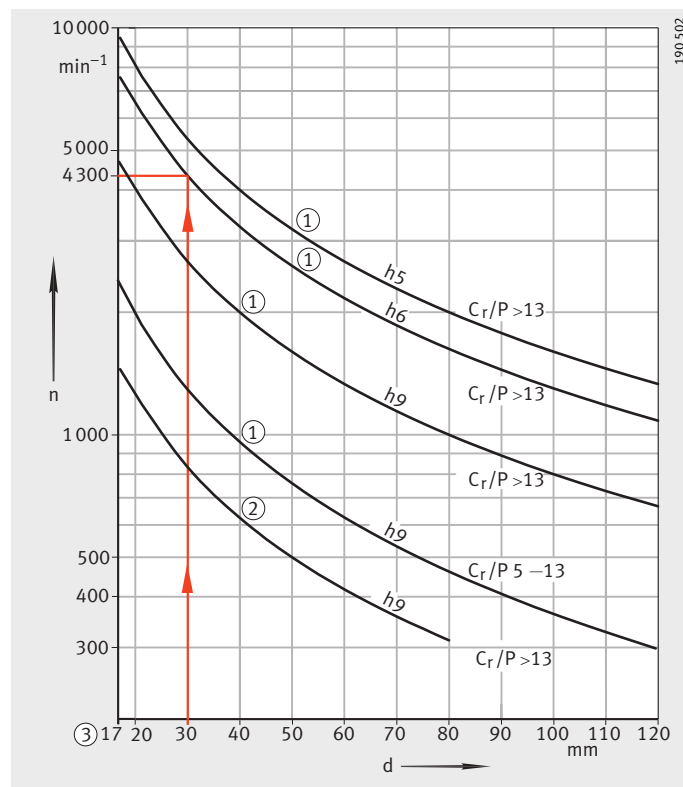

- ① For insert bearings with L, P, R seals
- ② For insert bearings with T seals
- ③ Ball set identical for $d = 12\text{ mm}, 15\text{ mm}, 17\text{ mm}$
 $d =$ bearing bore diameter
 $n =$ permissible speed

Figure 13
Permissible speeds of radial insert ball bearings

Shaft tolerances for radial insert ball bearings – recommendations

The permissible shaft tolerance is dependent on the speed and load. Tolerances from h6 to h9 are possible.

Conventional drawn shafts will suffice for most applications.

Radial insert ball bearings

Accuracy Standard tolerances of radial insert ball bearings

The outside diameter of the bearings corresponds to tolerance class PN in accordance with DIN 620-2. The inner ring bore has a plus tolerance to facilitate mounting of the bearing.

Standard tolerances for the bearings are shown in the table.

Tolerances of radial insert ball bearings

Inner ring				Outer ring			
Nominal dimension d mm		Bore ¹⁾ μm		Nominal dimension D mm		Outside diameter ²⁾ μm	
over	incl.	min.	max.	over	incl.	max.	min.
12	18	0	+18	30	50	0	-11
18	24	0	+18	50	80	0	-13
24	30	0	+18	80	120	0	-15
30	40	0	+18	120	150	0	-18
40	50	0	+18	150	180	0	-25
50	60	0	+18	180	250	0	-30
60	90	0	+25	-	-	-	-
90	120	0	+30	-	-	-	-

¹⁾ This corresponds to the arithmetic mean value derived from the largest and smallest diameters (measured using a two-point measuring device).

²⁾ In the case of sealed bearings, the largest and smallest values of the outside diameter can deviate from the mean value by approximately 0,03 mm.

Radial internal clearance of radial insert ball bearings

The radial internal clearance is given in the table.

The radial internal clearance of most series is C3 and is thus larger than for normal deep groove ball bearings, see table.

The larger internal clearance allows better support of angular misalignment and shaft deflection.

Radial internal clearance

Bore		Radial internal clearance							
d mm		CN μm		C3 μm		C4 μm		C5 μm	
over	incl.	min.	max.	min.	max.	min.	max.	min.	max.
2,5	10	2	13	8	23	14	29	20	37
10	18	3	18	11	25	18	33	25	45
18	24	5	20	13	28	20	36	28	48
24	30	5	20	13	28	23	41	30	53
30	40	6	20	15	33	28	46	40	64
40	50	6	23	18	36	30	51	45	73
50	65	8	28	23	43	38	61	55	90
65	80	10	30	25	51	46	71	65	105
80	100	12	36	30	58	53	84	75	120
100	120	15	41	36	66	61	97	90	140
120	140	18	48	41	81	71	114	105	160
140	160	18	53	46	91	81	130	120	180



Radial insert ball bearings with eccentric locking collar

Spherical outer ring

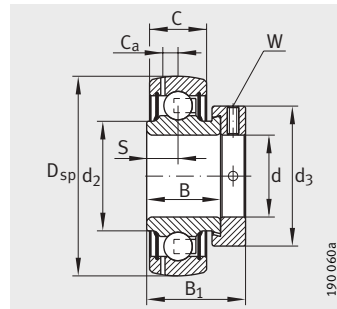

GRAE...-NPP-B

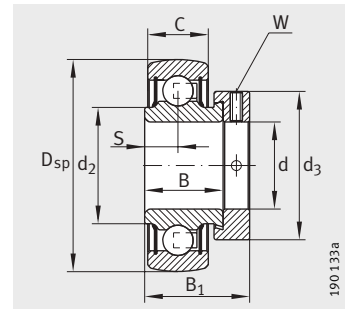

RAE...-NPP-B, RALE...-NPP-B

Dimension table · Dimensions in mm							
Designation ¹⁾	Mass m ≈kg	Dimensions					
		d	D _{sp}	C	C ₂	B	S
GRAE12-NPP-B	0,12	12	40	12	–	19	6,5
RAE12-NPP-B	0,12	12	40	12	–	19	6,5
GRAE15-NPP-B	0,12	15	40	12	–	19	6,5
RAE15-NPP-B	0,12	15	40	12	–	19	6,5
GRAE17-NPP-B	0,12	17	40	12	–	19	6,5
RAE17-NPP-B	0,12	17	40	12	–	19	6,5
GE17-KRR-B	0,16	17	40	12	16,6	27,8	13,9
GE17-KRR-B-FA164	0,16	17	40	12	16,6	27,8	13,9
GRAE20-NPP-B	0,16	20	47	14	–	21,4	7,5
GRAE20-NPP-B-FA125.5	0,16	20	47	14	–	21,4	7,5
RAE20-NPP-B	0,16	20	47	14	–	21,4	7,5
RALE20-NPP-B	0,09	20	42	12	–	16,7	6
GE20-KRR-B	0,2	20	47	14	16,6	34,1	17,1
GE20-KRR-B-FA125.5	0,2	20	47	14	16,6	34,1	17,1
GE20-KRR-B-FA164	0,2	20	47	14	16,6	34,1	17,1
GE20-KTT-B	0,2	20	47	14	16,6	34,1	17,1
GE20-KLL-B	0,2	20	47	14	16,6	34,1	17,1
GRAE25-NPP-B	0,19	25	52	15	–	21,4	7,5
GRAE25-NPP-B-FA125.5	0,19	25	52	15	–	21,4	7,5
RAE25-NPP-B	0,19	25	52	15	–	21,4	7,5
RALE25-NPP-B	0,12	25	47	12	–	17,5	6
E25-KRR-B	0,25	25	52	15	16,7	34,9	17,5
GE25-KRR-B	0,25	25	52	15	16,7	34,9	17,5
GE25-KRR-B-FA125.5	0,25	25	52	15	16,7	34,9	17,5
GE25-KRR-B-FA164	0,25	25	52	15	16,7	34,9	17,5
GE25-KRR-B-FA101	0,25	25	52	15	16,7	34,9	17,5
GE25-KTT-B	0,25	25	52	15	20,2	34,9	17,5
GE25-KRR-B-2C	0,25	25	52	15	24,6	34,9	17,5
GE25-KLL-B	0,25	25	52	15	20,2	34,9	17,5

¹⁾ Permissible speeds of radial insert ball bearings: see page 1049.

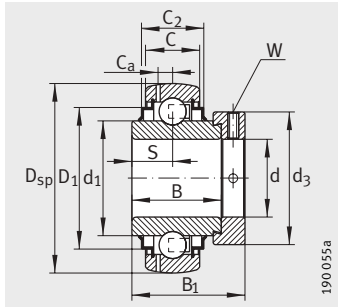

GE..-KRR-B, E..-KRR-B, GE..-KLL-B

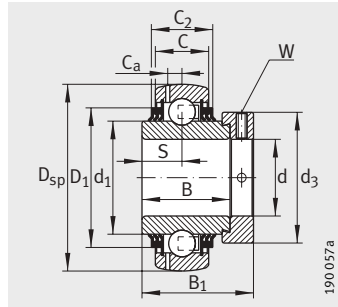

GE..-KTT-B

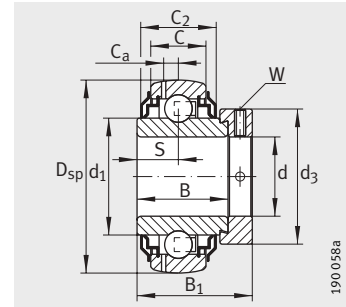

GE..-KRR-B-2C

							Basic load ratings	
d ₁	d ₂	D ₁	C _a	B ₁	d ₃ max.	W	dyn. C _r N	stat. C _{0r} N
-	23	-	3,4	28,6	28	3	9 800	4 750
-	23	-	-	28,6	28	3	9 800	4 750
-	23	-	3,4	28,6	28	3	9 800	4 750
-	23	-	-	28,6	28	3	9 800	4 750
-	23	-	3,4	28,6	28	3	9 800	4 750
-	23	-	-	28,6	28	3	9 800	4 750
23,9	-	31,6	3,4	37,4	28	3	9 800	4 750
23,9	-	31,6	3,4	37,4	28	3	9 800	4 750
-	26,9	-	4	31	33	3	12 800	6 600
-	26,9	-	4	31	33	3	12 800	6 600
-	26,9	-	-	31	33	3	12 800	6 600
-	25,4	-	-	24,5	30	2,5	9 400	5 000
27,6	-	37,4	4	43,7	33	3	12 800	6 600
27,6	-	37,4	4	43,7	33	3	12 800	6 600
27,6	-	37,4	4	43,7	33	3	12 800	6 600
27,6	-	37,4	4	43,7	33	3	12 800	6 600
27,6	-	37,4	4	43,7	33	3	12 800	6 600
-	30,5	-	3,9	31	37,5	3	14 000	7 800
-	30,5	-	3,9	31	37,5	3	14 000	7 800
-	30,5	-	-	31	37,5	3	14 000	7 800
-	30	-	-	25,5	36	2,5	10 100	5 900
33,8	-	42,5	-	44,5	37,5	3	14 000	7 800
33,8	-	42,5	3,9	44,5	37,5	3	14 000	7 800
33,8	-	42,5	3,9	44,5	37,5	3	14 000	7 800
33,8	-	42,5	3,9	44,5	37,5	3	14 000	7 800
33,8	-	42,5	3,9	44,5	37,5	3	14 000	7 800
33,8	-	42,5	3,9	44,5	37,5	3	14 000	7 800
33,8	-	-	3,9	44,5	37,5	3	14 000	7 800
33,8	-	42,5	3,9	44,5	37,5	3	14 000	7 800



Radial insert ball bearings with eccentric locking collar

Spherical outer ring

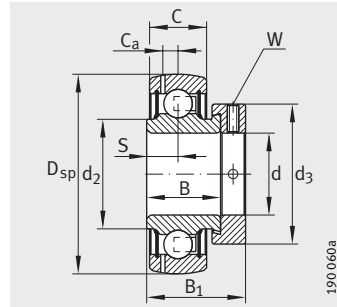

GRAE..-NPP-B

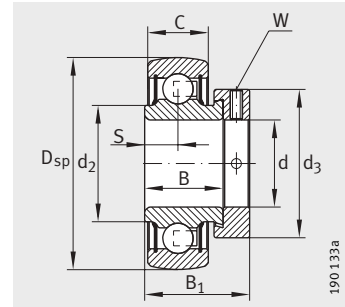

RAE..-NPP-B, RALE..-NPP-B

Dimension table (continued) · Dimensions in mm

Designation ¹⁾	Mass m ≈kg	Dimensions					
		d	D _{sp}	C	C ₂	B	S
GRAE30-NPP-B	0,31	30	62	18	–	23,8	9
GRAE30-NPP-B-FA125.5	0,31	30	62	18	–	23,8	9
RAE30-NPP-B	0,31	30	62	18	–	23,8	9
RALE30-NPP-B	0,17	30	55	13	–	18,5	6,5
E30-KRR-B	0,38	30	62	18	20,7	36,5	18,3
GE30-KRR-B	0,38	30	62	18	20,7	36,5	18,3
GE30-KRR-B-FA125.5	0,38	30	62	18	20,7	36,5	18,3
GE30-KRR-B-FA164	0,38	30	62	18	20,7	36,5	18,3
GE30-KRR-B-FA101	0,38	30	62	18	20,7	36,5	18,3
GNE30-KRR-B	0,54	30	72	20	24	36,6	17,5
GE30-KTT-B	0,38	30	62	18	20,7	36,5	18,3
GE30-KRR-B-2C	0,38	30	62	18	27,2	36,5	18,3
GE30-KLL-B	0,38	30	62	18	20,6	36,5	18,3
GRAE35-NPP-B	0,48	35	72	19	–	25,4	9,5
GRAE35-NPP-B-FA125.5	0,48	35	72	19	–	25,4	9,5
RAE35-NPP-B	0,48	35	72	19	–	25,4	9,5
E35-KRR-B	0,55	35	72	19	22,5	37,7	18,8
GE35-KRR-B	0,55	35	72	19	22,5	37,7	18,8
GE35-KRR-B-FA125.5	0,55	35	72	19	22,5	37,7	18,8
GE35-KRR-B-FA164	0,55	35	72	19	22,5	37,7	18,8
GNE35-KRR-B	0,73	35	80	22	25	38,1	18,3
GE35-KTT-B	0,55	35	72	19	22,5	37,7	18,8
GE35-KRR-B-2C	0,55	35	72	19	29,2	37,7	18,8
GE35-KLL-B	0,55	35	72	19	25,4	37,7	18,8

¹⁾ Permissible speeds of radial insert ball bearings: see page 1049.

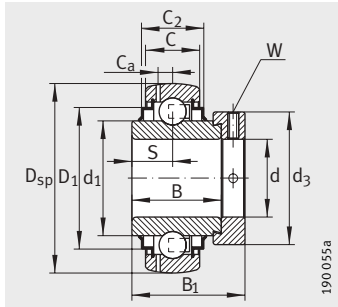

GE..-KRR-B, GNE..-KRR-B,
E..-KRR-B, GE..-KLL-B

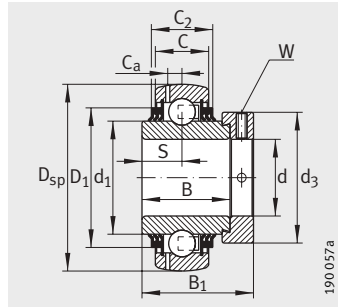

GE..-KTT-B

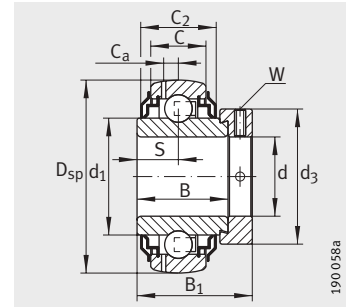

GE..-KRR-B-2C

							Basic load ratings	
d ₁	d ₂	D ₁	C _a	B ₁	d ₃ max.	W	dyn. C _r N	stat. C _{0r} N
-	37,4	-	4,7	35,8	44	4	19 500	11 300
-	37,4	-	4,7	35,8	44	4	19 500	11 300
-	37,4	-	-	35,8	44	4	19 500	11 300
-	35,7	-	-	26,5	42,5	2,5	13 200	8 300
40,2	-	52	-	48,5	44	4	19 500	11 300
40,2	-	52	4,7	48,5	44	4	19 500	11 300
40,2	-	52	4,7	48,5	44	4	19 500	11 300
40,2	-	52	4,7	48,5	44	4	19 500	11 300
44	-	60,2	6,2	50,2	51	5	29 500	16 700
40,2	-	52	4,7	48,5	44	4	19 500	11 300
40,2	-	-	4,7	48,5	44	4	19 500	11 300
40,2	-	52	4,7	48,5	44	4	19 500	11 300
-	44,6	-	5,6	39	51	5	25 500	15 300
-	44,6	-	5,6	39	51	5	25 500	15 300
-	44,6	-	-	39	51	5	25 500	15 300
46,8	-	60,3	-	51,3	51	5	25 500	15 300
46,8	-	60,3	5,6	51,3	51	5	25 500	15 300
46,8	-	60,3	5,6	51,3	51	5	25 500	15 300
46,8	-	60,3	5,6	51,3	51	5	25 500	15 300
48	-	66,6	6,9	51,6	55	5	36 500	20 900
46,8	-	60,3	5,6	51,3	51	5	25 500	15 300
46,8	-	-	5,6	51,3	51	5	25 500	15 300
46,8	-	60,3	5,6	51,3	51	5	25 500	15 300



Radial insert ball bearings with eccentric locking collar

Spherical outer ring

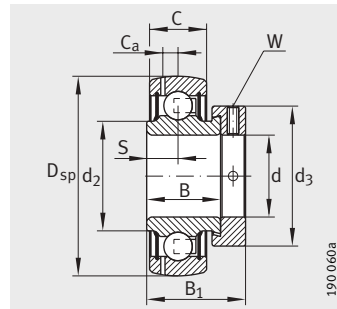

GRAE..-NPP-B

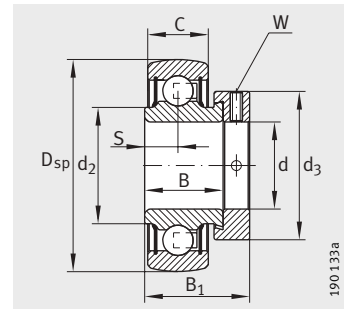

RAE..-NPP-B

Dimension table (continued) · Dimensions in mm

Designation ¹⁾	Mass m ≈kg	Dimensions					
		d	D _{sp}	C	C ₂	B	S
GRAE40-NPP-B	0,62	40	80	21	–	30,2	11
GRAE40-NPP-B-FA125.5	0,62	40	80	21	–	30,2	11
RAE40-NPP-B	0,62	40	80	21	–	30,2	11
E40-KRR-B	0,74	40	80	21	23,5	42,9	21,4
GE40-KRR-B	0,74	40	80	21	23,5	42,9	21,4
GE40-KRR-B-FA125.5	0,74	40	80	21	23,5	42,9	21,4
GE40-KRR-B-FA164	0,74	40	80	21	23,5	42,9	21,4
GE40-KRR-B-FA101	0,74	40	80	21	23,5	42,9	21,4
GNE40-KRR-B	1,09	40	90	23	26	41	18
GE40-KTT-B	0,74	40	80	21	28,1	42,9	21,4
GE40-KRR-B-2C	0,74	40	80	21	31,9	42,9	21,4
GE40-KLL-B	0,74	40	80	21	28,1	42,9	21,4
GRAE45-NPP-B	0,69	45	85	22	–	30,2	11
GRAE45-NPP-B-FA125.5	0,69	45	85	22	–	30,2	11
GE45-KRR-B	0,81	45	85	22	26,4	42,9	21,4
GE45-KRR-B-FA125.5	0,81	45	85	22	26,4	42,9	21,4
GE45-KTT-B	0,86	45	85	22	26,4	42,9	21,4
GE45-KLL-B	0,81	45	85	22	26,4	42,9	21,4
GRAE50-NPP-B	0,77	50	90	22	–	30,2	11
GRAE50-NPP-B-FA125.5	0,77	50	90	22	–	30,2	11
RAE50-NPP-B	0,77	50	90	22	–	30,2	11
GE50-KRR-B	1	50	90	22	26,4	49,2	24,6
GE50-KRR-B-FA125.5	1	50	90	22	26,4	49,2	24,6
GE50-KRR-B-FA164	1	50	90	22	26,4	49,2	24,6
GE50-KRR-B-FA101	1	50	90	22	26,4	49,2	24,6
GNE50-KRR-B	1,87	50	110	29	31	49,2	24,6
GE50-KTT-B	1,06	50	90	22	26,4	49,2	24,6
GE50-KLL-B	1	50	90	22	26,4	49,2	24,6
GRAE55-NPP-B	0,81	55	100	25	–	32,5	12
GE55-KRR-B	1,42	55	100	25	29	55,5	27,8
GE55-KTT-B	1,42	55	100	25	29	55,5	27,8

¹⁾ Permissible speeds of radial insert ball bearings: see page 1049.

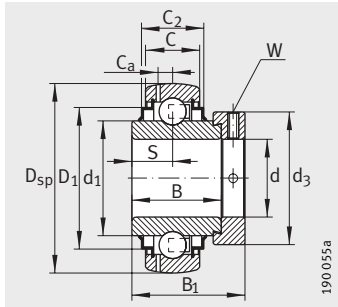

GE..-KRR-B, GNE...-KRR-B,
E...-KRR-B, GE...-KLL-B

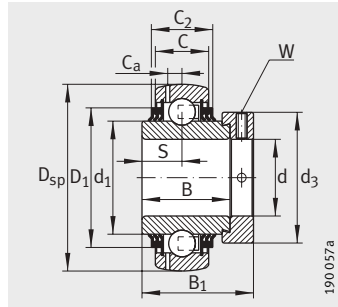

GE...-KTT-B

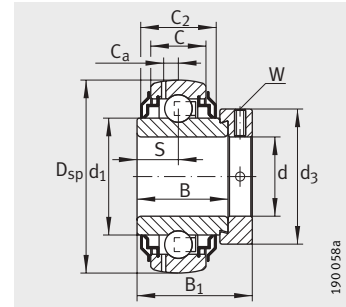

GE...-KRR-B-2C

							Basic load ratings	
d ₁	d ₂	D ₁	C _a	B ₁	d ₃ max.	W	dyn. C _r N	stat. C _{0r} N
-	49,4	-	6,4	43,8	58	5	32 500	19 800
-	49,4	-	6,4	43,8	58	5	32 500	19 800
-	49,4	-	-	43,8	58	5	32 500	19 800
52,3	-	68,3	-	56,5	58	5	32 500	19 800
52,3	-	68,3	6,4	56,5	58	5	32 500	19 800
52,3	-	68,3	6,4	56,5	58	5	32 500	19 800
52,3	-	68,3	6,4	56,5	58	5	32 500	19 800
52,3	-	68,3	6,4	56,5	58	5	32 500	19 800
53,8	-	74,5	7,5	54,6	63	5	44 500	26 000
52,3	-	68,3	6,4	56,5	58	5	32 500	19 800
52,3	-	-	6,4	56,5	58	5	32 500	19 800
52,3	-	68,3	6,4	56,5	58	5	32 500	19 800
-	54,3	-	6,4	43,8	63	5	32 500	20 400
-	54,3	-	6,4	43,8	63	5	32 500	20 400
57,9	-	72,3	6,4	56,5	63	5	32 500	20 400
57,9	-	72,3	6,4	56,5	63	5	32 500	20 400
57,9	-	72,3	6,4	56,5	63	5	32 500	20 400
57,9	-	72,3	6,4	56,5	63	5	32 500	20 400
-	59,4	-	6,9	43,8	69	5	35 000	23 200
-	59,4	-	6,9	43,8	69	5	35 000	23 200
-	59,4	-	-	43,8	69	5	35 000	23 200
62,8	-	77,3	6,9	62,8	69	5	35 000	23 200
62,8	-	77,3	6,9	62,8	69	5	35 000	23 200
62,8	-	77,3	6,9	62,8	69	5	35 000	23 200
62,8	-	77,3	6,9	62,8	69	5	35 000	23 200
68,8	-	92,7	8,7	66,5	75,8	5	62 000	38 000
62,8	-	77,3	6,9	62,8	69	5	35 000	23 200
62,8	-	77,3	6,9	62,8	69	5	35 000	23 200
-	66	-	7	48,4	76	5	43 500	29 000
69,8	-	85,9	7	71,4	76	5	43 500	29 000
69,8	-	85,9	7	71,4	76	5	43 500	29 000



Radial insert ball bearings with eccentric locking collar

Spherical outer ring

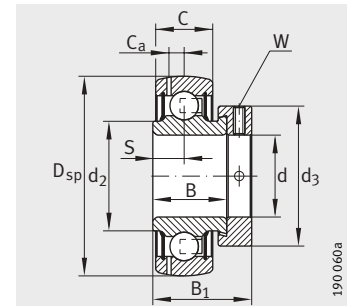

GRAE..-NPP-B

Dimension table (continued) · Dimensions in mm							
Designation ¹⁾	Mass m ≈kg	Dimensions					
		d	D _{sp}	C	C ₂	B	S
GRAE60-NPP-B	1,4	60	110	24	—	37,1	13,5
GRAE60-NPP-B-FA125.5	1,4	60	110	24	—	37,1	13,5
GE60-KRR-B	1,84	60	110	24	29	61,9	31
GE60-KRR-B-FA164	1,84	60	110	24	29	61,9	31
GE60-KRR-B-FA101	1,84	60	110	24	29	61,9	31
GNE60-KRR-B	2,97	60	130	33	37,2	52	23
GE60-KTT-B	1,84	60	110	24	29	61,9	31
GE65-214-KRR-B	2,71	65	125	28	32	48,5	21,5
GE65-214-KRR-B-FA164	2,71	65	125	28	32	48,5	21,5
GE65-214-KTT-B	2,71	65	125	28	32	48,5	21,5
GE70-KRR-B	2,45	70	125	28	32	48,5	21,5
GE70-KRR-B-FA164	2,45	70	125	28	32	48,5	21,5
GE70-KRR-B-FA101	2,45	70	125	28	32	48,5	21,5
GNE70-KRR-B	4,37	70	150	37	41	58	26
GE70-KTT-B	2,45	70	125	28	32	48,5	21,5
GE75-KRR-B	2,65	75	130	28	30,5	49,5	21,5
GE75-KRR-B-FA164	2,65	75	130	28	30,5	49,5	21,5
GE75-KRR-B-FA101	2,65	75	130	28	30,5	49,5	21,5
GE75-KTT-B	2,65	75	130	28	30,5	49,5	21,5
GE80-KRR-B	2,95	80	140	30	38	53,2	23,4
GE80-KRR-B-AH01-FA164	2,95	80	140	30	38	53,2	23,4
GNE80-KRR-B ²⁾	7,1	80	170	41	51	73	34
GE80-KTT-B	2,95	80	140	30	38	53,2	23,4
GE90-KRR-B ²⁾	3,72	90	160	32	35	52	23
GE90-KRR-B-FA164 ²⁾	3,72	90	160	32	35	52	23
GNE90-KRR-B ²⁾	8,07	90	190	45	52,6	77,5	35,5
GE100-KRR-B ²⁾	4,65	100	180	36	39	57,5	25,5
GNE100-KRR-B ²⁾	12,3	100	215	49	59,4	86	39,5
GE120-KRR-B ²⁾	6,93	120	215	40	45	63,5	28,5
GE120-KRR-B-FA101 ²⁾	6,93	120	215	40	45	63,5	28,5

¹⁾ Permissible speeds of radial insert ball bearings: see page 1049.

²⁾ Lubrication groove in outer ring.

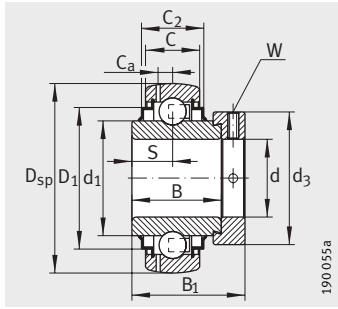

GE..-KRR-B, GNE..-KRR-B

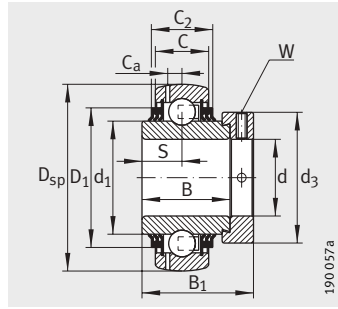

GE..-KTT-B

							Basic load ratings	
d ₁	d ₂	D ₁	C _a	B ₁	d ₃	W	dyn. C _r N	stat. C _{0r} N
-	72	-	7,2	53,1	84	5	52 000	36 000
-	72	-	7,2	53,1	84	5	52 000	36 000
76,5	-	94,5	7,2	77,9	84	5	52 000	36 000
76,5	-	94,5	7,2	77,9	84	5	52 000	36 000
76,5	-	94,5	7,2	77,9	84	5	52 000	36 000
79,4	-	109	11,2	68	89	5	82 000	52 000
76,5	-	94,5	7,2	77,9	84	5	52 000	36 000
85,2	-	109	8,9	66	96	6	62 000	44 000
85,2	-	109	8,9	66	96	6	62 000	44 000
85,2	-	109	8,9	66	96	6	62 000	44 000
85,2	-	109	8,9	66	96	6	62 000	44 000
85,2	-	109	8,9	66	96	6	62 000	44 000
85,2	-	109	8,9	66	96	6	62 000	44 000
92,2	-	127	12	75,5	102	6	104 000	68 000
85,2	-	109	8,9	66	96	6	62 000	44 000
90	-	113	8,5	67	100	6	62 000	44 500
90	-	113	8,5	67	100	6	62 000	44 500
90	-	113	8,5	67	100	6	62 000	44 500
90	-	113	8,5	67	100	6	62 000	44 500
97	-	120	8,8	70,7	108	6	72 000	54 000
97	-	120	8,8	70,7	108	6	72 000	54 000
109	-	142,8	13,2	93,6	108	6	123 000	87 000
97	-	120	8,8	70,7	108	6	72 000	54 000
109,4	-	138	10	69,5	118	6	96 000	72 000
109,4	-	138	10	69,5	118	6	96 000	72 000
122,2	-	161,3	14,3	101	132	6	143 000	107 000
122,2	-	155,5	11,2	75	132	6	122 000	93 000
137,1	-	182,8	16,7	109,4	145	6	174 000	140 000
146,4	-	186,5	12,8	81	152	6	155 000	131 000
146,4	-	186,5	12,8	81	152	6	155 000	131 000



Radial insert ball bearings with grub screws in inner ring

Spherical outer ring

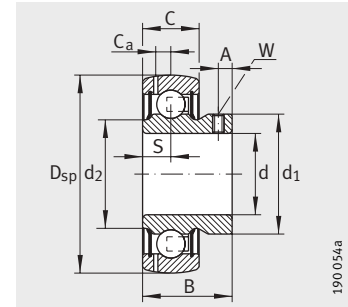

GAY..-NPP-B, AY..-NPP-B

Dimension table · Dimensions in mm							
Designation ¹⁾	Mass m ≈kg	Dimensions					
		d	D _{sp}	C	C ₂	B	S
GAY12-NPP-B	0,1	12	40	12	–	22	6
GAY12-NPP-B-FA164	0,1	12	40	12	–	22	6
AY12-NPP-B	0,1	12	40	12	–	22	6
GYE12-KRR-B	0,11	12	40	12	16,6	27,4	11,5
GYE12-KRR-B-VA	0,11	12	40	12	13,5	25	9,6
GAY15-NPP-B	0,09	15	40	12	–	22	6
GAY15-NPP-B-FA164	0,09	15	40	12	–	22	6
AY15-NPP-B	0,09	15	40	12	–	22	6
GYE15-KRR-B	0,1	15	40	12	16,6	27,4	11,5
GYE15-KRR-B-VA	0,1	15	40	12	13,5	25	9,6
GYE16-KRR-B	0,1	16	40	12	16,6	27,4	11,5
GAY17-NPP-B	0,08	17	40	12	–	22	6
AY17-NPP-B	0,08	17	40	12	–	22	6
GYE17-KRR-B	0,09	17	40	12	16,6	27,4	11,5
GYE17-KRR-B-VA	0,09	17	40	12	13,5	25	9,6
GAY20-NPP-B	0,13	20	47	14	–	25	7
AY20-NPP-B	0,13	20	47	14	–	25	7
GYE20-KRR-B	0,17	20	47	14	16,6	31	12,7
GYE20-KRR-B-VA ²⁾	0,18	20	47	16	17,5	31	12,7
GAY25-NPP-B	0,16	25	52	15	–	27	7,5
AY25-NPP-B	0,16	25	52	15	–	27	7,5
GYE25-KRR-B	0,2	25	52	15	16,7	34,1	14,3
GYE25-KRR-B-VA ²⁾	0,21	25	52	17	18,5	34	14,3
GAY30-NPP-B	0,25	30	62	18	–	30	9
AY30-NPP-B	0,25	30	62	18	–	30	9
GYE30-KRR-B	0,33	30	62	18	20,7	38,1	15,9
GYE30-KRR-B-VA ²⁾	0,4	30	62	19	20,5	38,1	15,9
GAY35-NPP-B	0,39	35	72	19	–	35	9,5
GYE35-KRR-B	0,49	35	72	19	22,5	42,9	17,5
GYE35-KRR-B-VA ²⁾	0,43	35	72	20	21,5	42,9	17,5

¹⁾ Permissible speeds of radial insert ball bearings: see page 1049.

²⁾ Lubrication groove in outer ring.

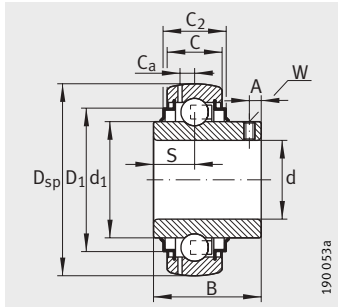

GYE..-KRR-B

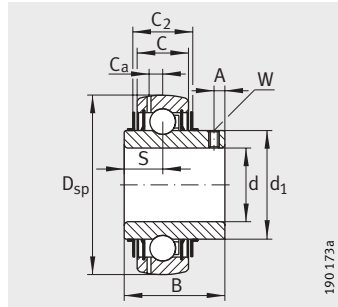

GYE..-KRR-B-VA

						Basic load ratings	
d ₁	d ₂	D ₁	C _a	A	W	dyn. C _r N	stat. C _{0r} N
23,9	22,9	-	3,4	4,2	2,5	9 800	4 750
23,9	22,9	-	3,4	4,2	2,5	9 800	4 750
23,9	22,9	-	-	4	2,5	9 800	4 750
23,9	-	31,6	3,4	4	2,5	9 800	4 750
23,9	-	-	3,4	4	2,5	9 800	4 750
23,9	22,9	-	3,4	4	2,5	9 800	4 750
23,9	22,9	-	3,4	4	2,5	9 800	4 750
23,9	22,9	-	-	4	2,5	9 800	4 750
23,9	-	31,6	3,4	4	2,5	9 800	4 750
24	-	-	3,4	4	2,5	9 800	4 750
23,9	-	31,6	3,4	4	2,5	9 800	4 750
23,9	22,9	-	3,4	4	2,5	9 800	4 750
23,9	22,9	-	-	4	2,5	9 800	4 750
23,9	-	31,6	3,4	4	2,5	9 800	4 750
23,9	-	-	3,4	4	2,5	9 800	4 750
28,3	26,7	-	4	4,5	2,5	12 800	6 600
28,3	26,7	-	-	4,5	2,5	12 800	6 600
27,6	-	37,4	4	4,5	2,5	12 800	6 600
29	-	-	4	5	2,5	12 800	6 600
33,5	30,4	-	3,9	5	2,5	14 000	7 800
33,5	30,4	-	-	5	2,5	14 000	7 800
33,8	-	42,5	3,9	5	2,5	14 000	7 800
34	-	-	4,5	5,5	2,5	14 000	7 800
39,4	37,3	-	4,7	5,8	3	19 500	11 300
39,4	37,3	-	-	5,8	3	19 500	11 300
40,2	-	52	4,7	5,8	3	19 500	11 300
40,4	-	-	5,2	6	3	19 500	11 300
46,9	44,5	-	5,6	6	3	25 500	15 300
46,8	-	60,3	5,6	6	3	25 500	15 300
47,4	-	-	5,6	6,5	3	25 500	15 300



Radial insert ball bearings with grub screws in inner ring

Spherical outer ring

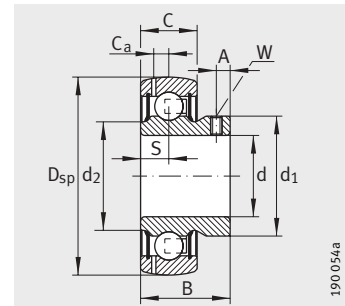

GAY..-NPP-B

Dimension table (continued) · Dimensions in mm							
Designation ¹⁾	Mass m ≈kg	Dimensions					
		d	D _{sp}	C	C ₂	B	S
GAY40-NPP-B	0,51	40	80	21	–	39,5	10,5
GYE40-KRR-B	0,65	40	80	21	23,5	49,2	19
GYE40-KRR-B-VA²⁾	0,63	40	80	21	22,5	49,2	19
GAY45-NPP-B	0,55	45	85	22	–	41,5	11
GYE45-KRR-B	0,7	45	85	22	26,4	49,2	19
GYE45-210-KRR-B	0,8	45	90	22	26,4	51,6	19
GAY50-NPP-B	0,62	50	90	22	–	43	11
GYE50-KRR-B	0,8	50	90	22	26,4	51,6	19
GYE55-KRR-B	1,1	55	100	25	29	55,6	22,2
GAY60-NPP-B	1,07	60	110	24	–	47	13
GYE60-KRR-B	1,32	60	110	24	29	65,1	25,4
GYE65-214-KRR-B	2,25	65	125	28	32	74,6	30,2
GYE70-KRR-B	1,95	70	125	28	32	74,6	30,2
GYE75-KRR-B	2,19	75	130	28	30,5	77,8	33,3
GYE80-KRR-B	2,93	80	140	30	38	82,6	33,3
GYE90-KRR-B²⁾	4,2	90	160	32	35	96	39,7

¹⁾ Permissible speeds of radial insert ball bearings: see page 1049.

²⁾ Lubrication groove in outer ring.

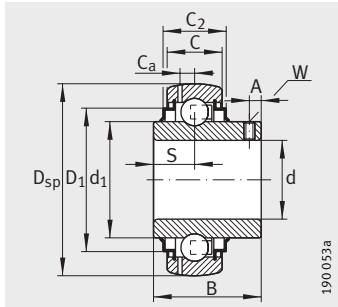

GYE..-KRR-B

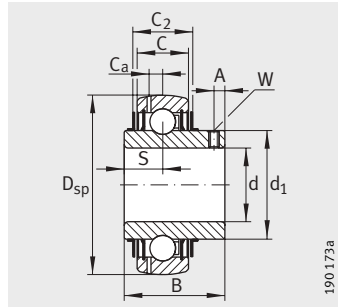

GYE..-KRR-B-VA

						Basic load ratings	
d ₁	d ₂	D ₁	C _a	A	W	dyn. C _r N	stat. C _{0r} N
52,4	49,3	-	6,4	8	4	32 500	19 800
52,3	-	68,3	6,4	8	4	32 500	19 800
52,7	-	-	5,9	8	4	32 500	19 800
57	54,3	-	6,4	8	4	32 500	20 400
57	-	72,3	6,4	8	4	32 500	20 400
62,9	-	77,3	6,9	8,5	4	35 000	23 200
62	59,3	-	6,9	9	4	35 000	23 200
62,8	-	77,3	6,9	8,5	4	35 000	23 200
69,8	-	85,9	7	9	4	43 500	29 000
76	73,6	-	7,2	10	5	52 000	36 000
76,5	-	94,5	7,2	10,1	5	52 000	36 000
85,2	-	109	8,9	12,1	5	62 000	44 000
85,2	-	109	8,9	12	5	62 000	44 000
90	-	113	8,5	12,7	5	62 000	44 500
97	-	120	8,8	12	5	72 000	54 000
109,4	-	138	10	12	6	96 000	72 000



Radial insert ball bearings with integral adapter sleeve

Spherical outer ring

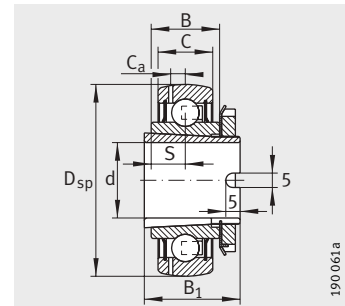

GSH..-2RSR-B

Dimension table · Dimensions in mm											
Designation ¹⁾	Mass m ≈kg	Dimensions							Limiting speed n _{G grease} min ⁻¹	Basic load ratings	
		d	D _{sp}	C	B	S	C _a	B ₁		dyn. C _r N	stat. C _{0r} N
GSH20-2RSR-B	0,14	20	47	14	15	7,5	4	28	10 000	12 700	6 600
GSH25-2RSR-B	0,17	25	52	15	15	7,5	3,9	28	8 000	13 600	7 800
GSH30-2RSR-B	0,27	30	62	18	18	9	4,7	32	6 600	18 900	11 300
GSH35-2RSR-B	0,43	35	72	19	19	9,5	5,8	34	5 700	24 900	15 300
GSH40-2RSR-B	0,54	40	80	21	22	11	6,4	38	5 000	29 500	19 800
GSH50-2RSR-B	0,64	50	90	22	22	11	6,5	40	4 000	33 000	19 900

¹⁾ Permissible speeds of radial insert ball bearings: see page 1049.

Radial insert ball bearings with drive slot

Non-locating bearings
Spherical outer ring

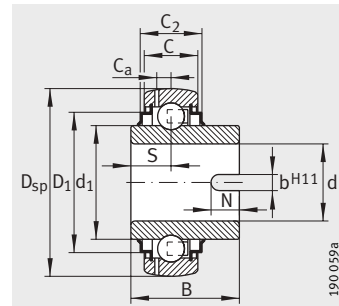

GLE..-KRR-B

Dimension table · Dimensions in mm															
Designation ¹⁾	Mass m ≈kg	Dimensions											Basic load ratings		
		d	D _{sp}	C	C ₂	B	S	d ₁	D ₁	C _a	N	b	dyn. C _r N	stat. C _{0r} N	
GLE20-KRR-B	0,16	20	47	14	16,6	34,1	15,6	27,6	37,4	4	7	7	12 800	6 600	
GLE25-KRR-B	0,19	25	52	15	16,7	34,9	14,7	33,8	42,5	3,9	8	7	14 000	7 800	
GLE30-KRR-B	0,3	30	62	18	20,7	36,5	14,5	40,2	52	4,7	8	7	19 500	11 300	
GLE35-KRR-B	0,43	35	72	19	22,5	37,7	15,7	46,8	60,3	5,6	8	7	25 500	15 300	
GLE40-KRR-B	0,58	40	80	21	23,5	42,9	15,9	52,3	68,3	6,4	9	7	32 500	19 800	
GLE45-KRR-B	0,66	45	85	22	26,4	42,9	17,4	57,9	72,3	6,4	9	7	32 500	20 400	
GLE50-KRR-B	0,76	50	90	22	26,4	49,2	19	62,8	77,3	6,9	10	7	35 000	23 200	
GLE60-KRR-B	1,52	60	110	24	29	61,9	24,6	76,5	95,9	7,2	12	9	52 000	36 000	
GLE70-KRR-B	2,25	70	125	28	32	68,2	27	85,2	109	8,9	12	9	62 000	44 000	

¹⁾ Permissible speeds of radial insert ball bearings: see page 1049.



Radial insert ball bearings with eccentric locking collar

Cylindrical outer ring

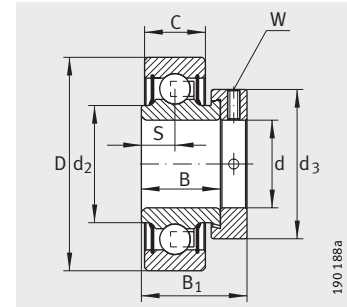

RAE..-NPP, RALE..-NPP

Dimension table · Dimensions in mm								
Designation ¹⁾	Mass m ≈kg	Dimensions						
		d	D	D ₂	C	C ₂	A	a
RAE12-NPP-FA106	0,12	12	40	–	12	–	–	–
RAE15-NPP-FA106	0,12	15	40	–	12	–	–	–
RAE17-NPP-FA106	0,12	17	40	–	12	–	–	–
RAE20-NPP-FA106	0,16	20	47	–	14	–	–	–
RAE20-NPP-NR	0,16	20	47	52,7	14	–	3,58 _{-0,25}	1,12
RALE20-NPP-FA106	0,09	20	42	–	12	–	–	–
E20-KLL	0,2	20	47	–	14	16,6	–	–
E20-KRR	0,2	20	47	–	14	16,6	–	–
RAE25-NPP-FA106	0,19	25	52	–	15	–	–	–
RAE25-NPP-NR	0,19	25	52	57,9	15	–	3,58 _{-0,25}	1,12
RALE25-NPP	0,12	25	47	–	12	–	–	–
E25-KLL	0,25	25	52	–	15	20,2	–	–
E25-KRR	0,25	25	52	–	15	16,7	–	–
RAE30-NPP-FA106	0,31	30	62	–	18	–	–	–
RAE30-NPP-NR	0,31	30	62	67,7	18	–	4,98 _{-0,3}	1,7
RALE30-NPP-FA106	0,17	30	55	–	13	–	–	–
E30-KLL	0,38	30	62	–	18	20,6	–	–
E30-KRR	0,38	30	62	–	18	20,7	–	–
RAE35-NPP-FA106	0,48	35	72	–	19	–	–	–
RAE35-NPP-NR	0,48	35	72	78,6	19	–	4,98 _{-0,3}	1,7
E35-KLL	0,55	35	72	–	19	25,4	–	–
E35-KRR	0,55	35	72	–	19	21,7	–	–
RAE40-NPP-FA106	0,62	40	80	–	21	–	–	–
RAE40-NPP-NR	0,62	40	80	86,6	21	–	4,98 _{-0,3}	1,7
E40-KLL	0,74	40	80	–	21	28,1	–	–
E40-KRR	0,74	40	80	–	21	23,5	–	–
RAE45-NPP-FA106	0,69	45	85	–	22	–	–	–
E45-KLL	0,81	45	85	–	22	26,4	–	–
E45-KRR	0,81	45	85	–	22	26,4	–	–
RAE50-NPP-FA106	0,77	50	90	–	22	–	–	–
E50-KLL	1	50	90	–	22	26,4	–	–
E50-KRR	1	50	90	–	22	26,4	–	–
RAE60-NPP	1,4	60	110	–	24	–	–	–
E60-KRR	1,84	60	110	–	24	29	–	–
E70-KRR	2,45	70	125	–	28	32	–	–

¹⁾ Permissible speeds of radial insert ball bearings: see page 1049.

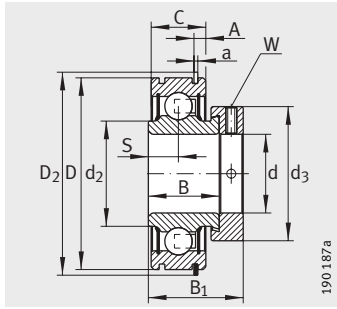

RAE..NPP-NR

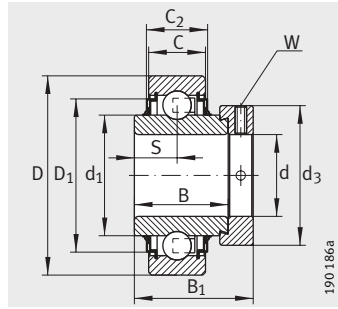

E..-KLL

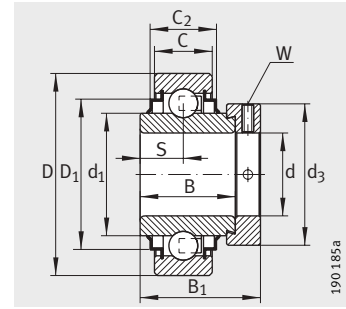

E..-KRR

								Basic load ratings	
B	S	d ₁	d ₂	D ₁	B ₁	d ₃ max.	W	dyn. C _r N	stat. C _{0r} N
19	6,5	-	23	-	28,6	28	3	9 800	4 750
19	6,5	-	23	-	28,6	28	3	9 800	4 750
19	6,5	-	23	-	28,6	28	3	9 800	4 750
21,4	7,5	-	26,9	-	31	33	3	12 800	6 600
21,4	7,5	-	26,9	-	31	33	3	12 800	6 600
16,7	6	-	25,4	-	24,5	30	2,5	9 400	5 000
34,1	17,1	27,6	-	37,4	43,7	33	3	12 800	6 600
34,1	17,1	27,6	-	37,4	43,7	33	3	12 800	6 600
21,4	7,5	-	30,5	-	31	37,5	3	14 000	7 800
21,4	7,5	-	30,5	-	31	37,5	3	14 000	7 800
17,5	6	-	30	-	25,5	36	2,5	10 100	5 900
34,9	17,5	33,8	-	42,5	44,5	37,5	3	14 000	7 800
34,9	17,5	33,8	-	42,5	44,5	37,5	3	14 000	7 800
23,8	9	-	37,4	-	35,8	44	4	19 500	11 300
23,8	9	-	37,4	-	35,8	44	4	19 500	11 300
18,5	6,5	-	35,7	-	26,5	42,5	2,5	13 200	8 300
36,5	18,3	40,2	-	52	48,5	44	4	19 500	11 300
36,5	18,3	40,2	-	52	48,5	44	4	19 500	11 300
25,4	9,5	-	44,6	-	39	51	5	25 500	15 300
25,4	9,5	-	44,6	-	39	51	5	25 500	15 300
37,7	18,8	46,8	-	60,3	51,3	51	5	25 500	15 300
37,7	18,8	46,8	-	60,3	51,3	51	5	25 500	15 300
30,2	11	-	49,4	-	43,8	58	5	32 500	19 800
30,2	11	-	49,4	-	43,8	58	5	32 500	19 800
42,9	21,4	52,3	-	68,3	56,5	58	5	32 500	19 800
42,9	21,4	52,3	-	68,3	56,5	58	5	32 500	19 800
30,2	11	-	54,5	-	43,8	63	5	32 500	20 400
42,9	21,4	57,9	-	72,3	56,5	63	5	32 500	20 400
42,9	21,4	57,9	-	72,3	56,5	63	5	32 500	20 400
30,2	11	-	59,4	-	43,8	69	5	35 000	23 200
49,2	24,6	62,8	-	77,3	62,8	69	5	35 000	23 200
49,2	24,6	62,8	-	77,3	62,8	69	5	35 000	23 200
37,1	13,5	-	72	-	53,1	84	5	52 000	36 000
61,9	31	76,5	-	94,5	77,9	84	5	52 000	36 000
48,5	21,5	85,2	-	109	66	96	6	62 000	44 000



Inch size radial insert ball bearings

Spherical or cylindrical outer ring

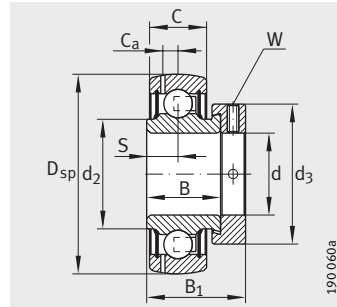

GRA..-NPP-B-AS2/V

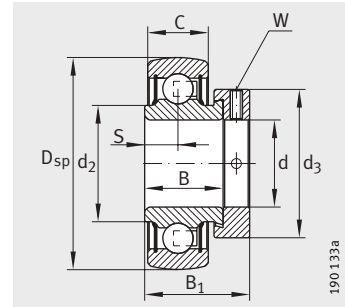

RA..-NPP-B

Dimension table · Dimensions in mm										
Shaft diameter d		Designation ¹⁾	Mass m ≈kg	Dimensions						
				D _{sp}	D	B	B ₁	C	C _a	C ₂
inch	mm									
5/8	15,8750	GRA010-NPP-B-AS2/V	0,12	40	–	19	28,6	12	3,4	–
		RA010-NPP	0,12	–	40	19	28,6	12	–	–
3/4	19,0500	GRA012-NPP-B-AS2/V	0,16	47	–	21,4	31	14	3,4	–
		GY1012-KRR-B-AS2/V	0,17	47	–	31	–	14	3,4	16,6
		RAL012-NPP	0,09	–	42	16,7	24,6	12	–	–
		RA012-NPP	0,16	–	47	21,4	31	14	–	–
7/8	22,2250	GRA014-NPP-B-AS2/V	0,19	52	–	21,4	31	15	3,9	–
		RA014-NPP	0,19	–	52	21,4	31	15	–	–
15/16	23,8125	G1015-KRR-B-AS2/V	0,25	52	–	34,9	44,5	15	3,9	16,7
1	25,4000	GRA100-NPP-B-AS2/V	0,19	52	–	21,4	31	15	3,9	–
		G1100-KRR-B-AS2/V	0,25	52	–	34,9	44,5	15	3,9	16,7
		GY1100-KRR-B-AS2/V	0,2	52	–	34,1	–	15	3,9	16,7
		RA100-NPP	0,19	–	52	21,4	31	15	–	–
		RA100-NPP-B	0,19	52	–	21,4	31	15	–	–
1 ¹ / ₁₆	26,9875	RA101-NPP	0,31	–	62	23,8	35,8	18	–	–
1 ¹ / ₈	28,5750	GRA102-NPP-B-AS2/V	0,31	62	–	23,8	35,8	18	4,7	–
		G1102-KRR-B-AS2/V	0,38	62	–	36,5	48,5	18	4,7	20,7
		RA102-NPP	0,31	–	62	23,8	35,8	18	–	–
1 ³ / ₁₆	30,1625	GRA103-NPP-B-AS2/V	0,31	62	–	23,8	35,8	18	4,7	–
		G1103-KRR-B-AS2/V	0,38	62	–	36,5	48,5	18	4,7	20,7
		RA103-NPP	0,31	–	62	23,8	35,8	18	–	–
1 ¹ / ₄	31,7500	GRA104-206-NPP-B-AS2/V	0,31	62	–	23,8	35,8	18	4,7	–
		G1104-206-KRR-B-AS2/V	0,38	62	–	36,5	48,5	18	4,7	20,7
		GY1104-206-KRR-B-AS2/V	0,33	62	–	38,1	–	18	4,7	20,7
		GRA104-NPP-B-AS2/V	0,48	72	–	25,4	39	19	5,6	–
		G1104-KRR-B-AS2/V	0,55	72	–	37,7	51,3	19	5,6	22,5
		GY1104-KRR-B-AS2/V	0,49	72	–	42,9	–	19	5,6	22,5
		RA104-NPP-B	0,48	72	–	25,4	39	19	–	–
		RA104-NPP	0,48	–	72	25,4	39	19	–	–
		RA104-206-NPP-B	0,31	62	–	23,8	35,8	18	–	–
		RA104-206-NPP	0,31	–	62	23,8	35,8	18	–	9

¹⁾ Permissible speeds of radial insert ball bearings: see page 1049.

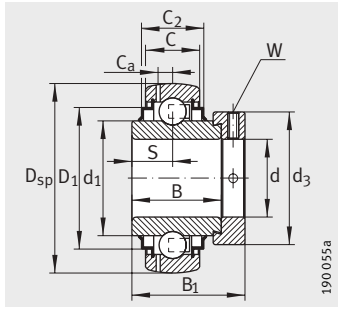

G.-KRR-B-AS2/V

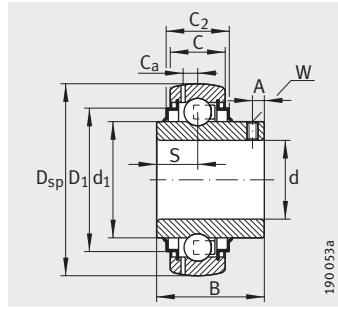

GY.-KRR-B-AS2/V

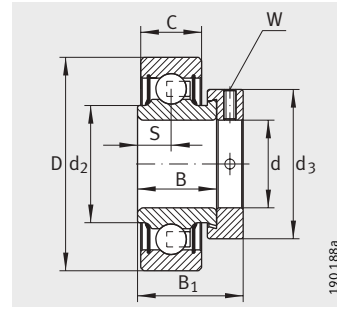

RA..-NPP, RAL..-NPP

S	d ₁	d ₂	D ₁	d ₃ max.	A	W "	Basic load ratings		Shaft diameter	
							dyn. C _r N	stat. C _{0r} N	d	
									inch	mm
6,5	-	23	-	28	-	1/8	9 800	4 750	5/8	15,8750
6,5	-	23	-	28	-	1/8	9 800	4 750		
7,5	-	26,9	-	33	-	1/8	12 800	6 600	3/4	19,0500
12,7	27,6	-	37,4	-	4,5	3/32	12 800	6 600		
6	-	25,4	-	30	-	1/8	9 400	5 000		
7,5	-	26,9	-	33	-	1/8	12 800	6 600		
7,5	-	30,5	-	37,5	-	1/8	14 000	7 800	7/8	22,2250
7,5	-	30,5	-	37,5	-	1/8	14 000	7 800		
17,5	33,8	-	42,5	37,5	-	1/8	14 000	7 800	15/16	23,8125
7,5	-	30,5	-	37,5	-	1/8	14 000	7 800	1	25,4000
17,5	33,8	-	42,5	37,5	-	1/8	14 000	7 800		
14,3	33,8	-	42,5	-	5	3/32	14 000	7 800		
7,5	-	30,5	-	37,5	-	1/8	14 000	7 800		
7,5	-	30,5	-	37,5	-	1/8	14 000	7 800		
9	-	37,4	-	44	-	5/32	19 500	11 300	1 1/16	26,9875
9	-	37,4	-	44	-	5/32	19 500	11 300	1 1/8	28,5750
18,3	40,2	-	52	44	-	5/32	19 500	11 300		
9	-	37,4	-	44	-	5/32	19 500	11 300		
9	-	37,4	-	44	-	5/32	19 500	11 300	1 3/16	30,1625
18,3	40,2	-	52	44	-	5/32	19 500	11 300		
9	-	37,4	-	44	-	5/32	19 500	11 300		
9	-	37,4	-	44	-	5/32	19 500	11 300	1 1/4	31,7500
18,3	40,2	-	52	44	-	5/32	19 500	11 300		
15,9	40,2	-	52	-	5	1/8	19 500	11 300		
9,5	-	44,6	-	51	-	3/16	25 500	15 300		
18,8	46,8	-	60,3	51	-	3/16	25 500	15 300		
17,5	46,8	-	60,3	-	6	1/8	25 500	15 300		
9,5	-	44,6	-	51	-	3/16	25 500	15 300		
9,5	-	44,6	-	51	-	3/16	25 500	15 300		
9	-	37,4	-	44	-	5/32	19 500	11 300		
9	-	37,4	-	44	-	5/32	19 500	11 300		



Inch size radial insert ball bearings

Spherical or cylindrical outer ring

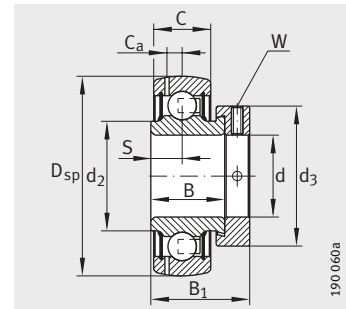

GRA..-NPP-B-AS2/V

Dimension table (continued) · Dimensions in mm										
Shaft diameter d		Designation ¹⁾	Mass m ≈kg	Dimensions						
				D_{sp}	D	B	B_1	C	C_a	C_2
inch	mm									
1 ³ / ₈	34,9250	GRA106-NPP-B-AS2/V	0,48	72	–	25,4	39	19	5,6	–
		G1106-KRR-B-AS2/V	0,55	72	–	37,7	51,3	19	5,6	22,5
1 ⁷ / ₁₆	36,5125	GRA107-NPP-B-AS2/V	0,48	72	–	25,4	39	19	5,6	–
		G1107-KRR-B-AS2/V	0,55	72	–	37,7	51,3	19	5,6	22,5
		RA107-NPP	0,48	–	72	25,4	39	19	–	–
1 ¹ / ₂	38,1000	GRA108-NPP-B-AS2/V	0,62	80	–	30,2	43,8	21	6,4	–
		G1108-KRR-B-AS2/V	0,74	80	–	42,9	56,5	21	6,4	23,5
		GY1108-KRR-B-AS2/V	0,65	80	–	49,2	–	21	6,4	23,5
		RA108-NPP-B	0,62	80	–	30,2	43,8	21	–	–
		RA108-NPP	0,62	–	80	30,2	43,8	21	–	–
1 ⁵ / ₈	41,2750	G1110-KRR-B-AS2/V	0,81	85	–	42,9	56,5	22	6,4	26,4
1 ¹¹ / ₁₆	42,8625	G1111-KRR-B-AS2/V	0,81	85	–	42,9	56,5	22	6,4	26,4
1 ³ / ₄	44,4500	GRA112-NPP-B-AS2/V	0,69	85	–	30,2	43,8	22	6,4	–
		G1112-KRR-B-AS2/V	0,81	85	–	42,9	56,5	22	6,4	26,4
		GY1112-KRR-B-AS2/V	0,7	85	–	49,2	–	22	6,4	26,4
1 ¹⁵ / ₁₆	49,2125	G1115-KRR-B-AS2/V	1	90	–	49,2	62,8	22	6,9	26,4
2	50,8000	G1200-KRR-B-AS2/V	1,42	100	–	55,5	71,4	25	7	29
		GY1200-KRR-B-AS2/V	1,1	100	–	55,6	–	25	7	29
2 ³ / ₁₆	55,5625	G1203-KRR-B-AS2/V	1,42	100	–	55,5	71,4	25	7	29
2 ⁷ / ₁₆	61,9125	G1207-KRR-B-AS2/V	1,84	110	–	61,9	77,9	24	7,2	29
2 ¹⁵ / ₁₆	74,6125	G1215-KRR-B-AS2/V	2,65	130	–	49,5	67	28	8,5	30,5
		GY1215-KRR-B-AS2/V	1,97	130	–	77,8	–	28	8,5	31,5

¹⁾ Permissible speeds of radial insert ball bearings: see page 1049.

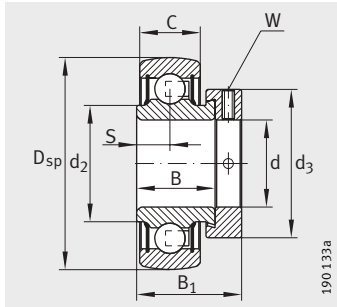

RA..-NPP-B

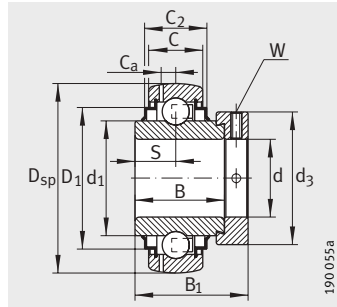

G..-KRR-B-AS2/V

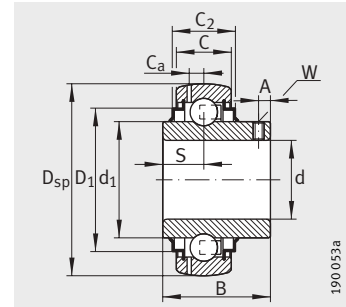

GY..-KRR-B-AS2/V

S	d ₁	d ₂	D ₁	d ₃ max.	A	W "	Basic load ratings		Shaft diameter d	
							dyn. C _r N	stat. C _{0r} N	inch	mm
							9,5	-	44,6	-
18,8	46,8	-	60,3	51	-	³ / ₁₆	25 500	15 300		
9,5	-	44,6	-	51	-	³ / ₁₆	25 500	15 300	1⁷/₁₆	36,5125
18,8	46,8	-	60,3	51	-	³ / ₁₆	25 500	15 300		
9,5	-	44,6	-	51	-	³ / ₁₆	25 500	15 300		
11	-	49,4	-	58	-	³ / ₁₆	32 500	19 800	1¹/₂	38,1000
21,4	52,3	-	68,3	58	-	³ / ₁₆	32 500	19 800		
19	52,3	-	68,3	-	8	⁵ / ₃₂	32 500	19 800		
11	-	49,4	-	58	-	³ / ₁₆	32 500	19 800		
11	-	49,4	-	58	-	³ / ₁₆	32 500	19 800		
21,4	57,9	-	72,3	63	-	³ / ₁₆	32 500	20 400	1⁵/₈	41,2750
21,4	57,9	-	72,3	63	-	³ / ₁₆	32 500	20 400	1¹¹/₁₆	42,8625
11	-	54,5	-	63	-	³ / ₁₆	32 500	20 400	1³/₄	44,4500
21,4	57,9	-	72,3	63	-	³ / ₁₆	32 500	20 400		
19	57,9	-	72,3	-	8	⁵ / ₃₂	32 500	20 400		
24,6	62,8	-	77,3	69	-	³ / ₁₆	35 000	23 200	1¹⁵/₁₆	49,2125
27,8	69,8	-	85,9	76	-	³ / ₁₆	43 500	29 000	2	50,8000
22,2	69,8	-	85,9	-	9	⁵ / ₃₂	43 500	29 000		
27,8	69,8	-	85,9	76	-	³ / ₁₆	43 500	29 000	2³/₁₆	55,5625
31	76,5	-	94,5	84	-	³ / ₁₆	52 000	36 000	2⁷/₁₆	61,9125
21,5	90	-	113	100	-	¹ / ₄	62 000	44 500	2¹⁵/₁₆	74,6125
33,4	90	-	113	-	12,7	³ / ₁₆	62 000	44 500		



Radial insert ball bearings with rubber interliner

Spherical or
cylindrical outside surface of rubber interliner

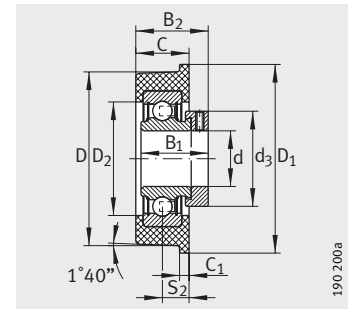

CRB

Dimension table · Dimensions in mm									
Designation ¹⁾		Mass m ≈kg	Dimensions						
Unit ²⁾	Radial insert ball bearing		d	D	D ₁	C	C ₂	C ₁	
	RABRB12/47-FA106	RAE12-NPP-B-FA106	0,15	12	47,3	–	17,6	–	–
	RCSMB15/65-FA106	RAE15-NPP-FA106	0,18	15	65,1	–	25,4	–	–
	RABRB15/47-FA106	RAE15-NPP-B-FA106	0,15	15	47,3	–	18	–	–
	RCSMB17/65-FA106	RAE17-NPP-FA106	0,18	17	65,1	–	25,4	–	–
	CRB20/83	RAE20-NPP	0,3	20	83,6	87,4	25,4	–	4,8
	CRB20/76	RAE20-NPP	0,3	20	77,5	80	25,4	–	5
	RCSMB20/65-FA106	RAE20-NPP-FA106	0,22	20	65,1	–	25,4	–	–
	RCRA20/46-FA106	RAE20-NPP-FA106	0,14	20	46	–	18,3	16	–
	RABRB20/52-FA106	RAE20-NPP-B-FA106	0,2	20	52,3	–	17,6	–	–
	CRB25/83	RAE25-NPP	0,32	25	83,6	87,4	25,4	–	4,8
	CRB25/70	RAE25-NPP	0,32	25	71,5	76	25	–	5
	CRB25/72	RAE25-NPP	0,32	25	73	80	25	–	5
	RCSMB25/65-FA106	RAE25-NPP-FA106	0,24	25	65,1	–	25,4	–	–
	RCRB25/57-FA106	RAE25-NPP-FA106	0,21	25	57,3	–	19,8	17,5	–
	RABRB25/62-FA106	RAE25-NPP-B-FA106	0,24	25	62,2	–	20,8	–	–
	CRB30/83	RAE30-NPP	0,41	30	83,6	87,4	28	–	4,8
	CRB30/92	RAE30-NPP	0,41	30	93	98	28	–	5
	RCSMA30/65-FA106	RAE30-NPP-FA106	0,32	30	65,1	–	25,4	–	–
	RABRA30/62-FA106	RAE30-NPP-B-FA106	0,3	30	62,2	–	20,8	–	–
	RABRB30/72-FA106	RAE30-NPP-B-FA106	0,38	30	72,2	–	23	–	–
	CRB35/110	RAE35-NPP	0,56	35	112,3	120	30	–	5
	RABRB35/80-FA106	RAE35-NPP-B-FA106	0,57	35	80,2	–	24	–	–
	RABRB40/85-FA106	RAE40-NPP-B-FA106	0,73	40	85	–	27	–	–
	RABRB50/100-FA106	RAE50-NPP-B-FA106	0,92	50	100,2	–	30	–	–

¹⁾ Permissible speeds of radial insert ball bearings: see page 1049.

²⁾ Operating temperature from –20 °C to +85 °C.

³⁾ Also available by agreement in NBR80.

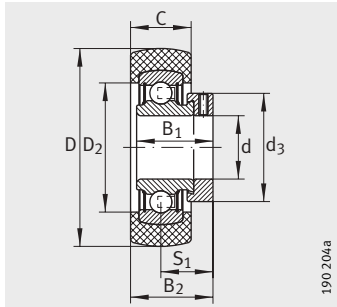

RABRA, RABRB

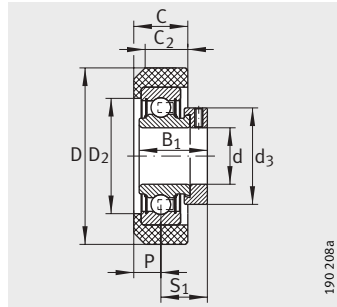

RCRA, RCRB

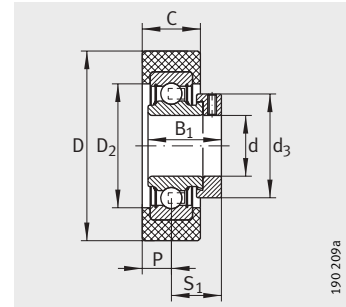

RCSMA, RCSMB

							Rubber ring		Basic load ratings	
S ₁	D ₂	B ₁	P	d ₃	S ₂	B ₂	Hardness Shore A	Load carrying capacity C _G	dyn. C _r	stat. C _{0r}
				max.			°	N	N	N
22,1	33,5	28,6	–	28	–	30,9	70	840	9 800	4 750
22,1	35	28,6	12,7	28	–	–	70	900	9 800	4 750
22,1	33,5	28,6	–	28	–	31,1	70	840	9 800	4 750
22,1	35	28,6	12,7	28	–	–	70	900	9 800	4 750
–	40	31	–	33	12,7	36,2	80	750	12 800	6 600
–	40	31	–	33	12,5	36	80	750	12 800	6 600
23,5	40	31	12,7	33	–	–	70	1 200	12 800	6 600
18,6	35	24,5	10	30	–	–	70	900	9 400	5 000
23,5	39	31	–	33	–	32,3	70	1 160	12 800	6 600
–	46	31	–	37,5	12,7	36,2	80	1 000	14 000	7 800
–	46	31	–	37,5	12,5	36	80	1 000	14 000	7 800
–	46	31	–	37,5	12,5	36	80	1 000	14 000	7 800
23,5	46	31	12,7	37,5	–	–	70	1 400	14 000	7 800
23,5	44,5	31	9,8	37,5	–	–	70	1 400	14 000	7 800
23,5	44,5	31	–	37,5	–	33,9	70 ³⁾	1 390	14 000	7 800
–	56	35,8	–	44	14	40,7	80	1 400	19 500	11 300
–	56	35,8	–	44	14	40,7	80	1 400	19 500	11 300
20	47,6	26,5	15	42,5	–	–	70	1 400	13 200	8 300
20	47	26,5	–	42,5	–	30,4	70	1 390	13 200	8 300
26,7	54	35,8	–	44	–	38,2	70 ³⁾	1 980	19 500	11 300
–	64	39	–	51	15	44,4	80	1 500	25 500	15 300
29,4	62	39	–	51	–	41,4	70	2 700	25 500	15 300
32,7	70	43,8	–	58	–	46,7	70 ³⁾	3 500	32 500	19 800
32,7	80	43,8	–	69	–	47,7	70 ³⁾	4 100	35 000	23 200



Radial insert ball bearings with steel aligning ring

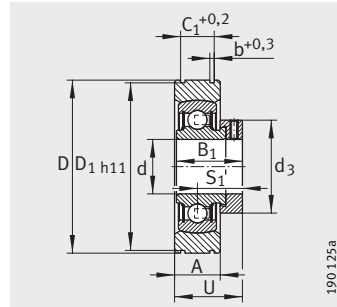

PE

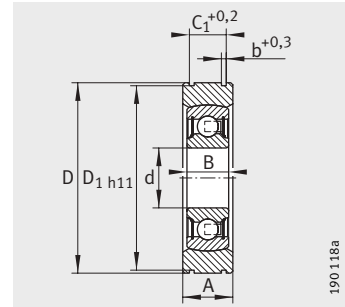

BE

Dimension table · Dimensions in mm

Designation	Mass Unit	Dimensions											Basic load ratings	
		d	D ³⁾	A	C ₁	b	D ₁	B	B ₁	S ₁	d ₃	U	dyn. C _r N	stat. C _{0r} N
PE20 ¹⁾	0,24	20	55	16	11,2	1,6	53,5	–	31	23,5	33	31,5	12 800	6 600
BE20 ²⁾	0,19	20	55	16	11,2	1,6	53,5	14	–	–	–	–	12 800	6 600
PE25 ¹⁾	0,31	25	62	17	11,2	1,6	60,5	–	31	23,5	37,5	32	14 000	7 800
BE25 ²⁾	0,25	25	62	17	11,2	1,6	60,5	15	–	–	–	–	14 000	7 800
PE30 ¹⁾	0,48	30	72	21	14,4	2,2	70,2	–	35,8	26,7	44	37,2	19 500	11 300
BE30 ²⁾	0,37	30	72	21	14,4	2,2	70,2	16	–	–	–	–	19 500	11 300
PE35 ¹⁾	0,64	35	80	21	14,4	2,2	78,2	–	39	29,4	51	40	25 500	15 300
BE35 ²⁾	0,45	35	80	21	14,4	2,2	78,2	17	–	–	–	–	25 500	15 300
PE40 ¹⁾	0,88	40	90	25	15,4	2,7	88	–	43,8	32,7	58	45,2	32 500	19 800
BE40 ²⁾	0,63	40	90	25	15,4	2,7	88	18	–	–	–	–	32 500	19 800

1) Permissible speeds of radial insert ball bearings RAE..NPP-B: see page 1049.

2) Permissible speeds of radial insert ball bearings 2..NPP-B: see page 1078.

3) Before splitting, dimension D corresponds to tolerance class PN according to DIN 620-2.

Deep groove ball bearings with extended inner ring

Cylindrical outer ring

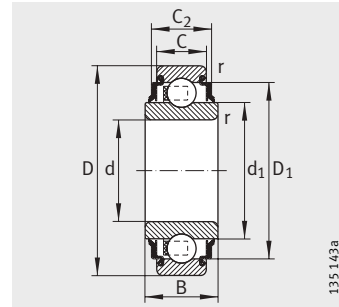

2..-KRR, 2..-KRR-AH..

Dimension table · Dimensions in mm												
Designation	Mass m ≈kg	Dimensions								Limiting speed n _G grease min ⁻¹	Basic load ratings	
		d	D	C	C ₂	d ₁	D ₁	B	r _{min}		dyn. C _r N	stat. C _{0r} N
203-KRR-AH05	0,08	13 ²⁾	40	12	12	24,5	30,6	18,3	0,6	13 000	9 800	4 750
202-KRR	0,05	15	35	11	11	21,5	28,8	14,4	0,6	14 600	7 600	3 700
203-KRR-AH02	0,07	16,2 ³⁾	40	12	12	24,5	32,6	18,3	0,6	13 000	9 800	4 750
203-KRR	0,07	17	40	12	12	24,5	32,9	18,3	0,6	13 000	9 800	4 750
204-KRR	0,12	20	47	14	14	28,7	38,7	17,7	1	11 000	12 800	6 600
205-KRR	0,16	25	52	15	16,7	33,8	42,6	21	1	8 800	14 000	7 800
206-KRR	0,24	30	62	16	19,6	40,2	52	24	1	7 300	19 500	11 300
207-KRR-AH03 ¹⁾	0,35	35	72	17	19,7	46,8	60,3	25	2	6 300	25 500	15 300
208-KRR-AH04 ¹⁾	0,46	38,892	80	21	21,2	52,3	68,2	27,5	1	5 500	32 500	19 800
208-KRR	0,44	40	80	18	20,5	52,3	68,2	27	1,1	5 500	32 500	19 800
209-KRR	0,53	45	85	19	26,4	57,9	72,3	30	1,1	4 900	32 500	20 400
210-KRR	0,58	50	90	20	24	62,8	77,6	30	1,1	4 400	35 000	23 200
211-KRR	0,85	55	100	21	27,5	69,8	85,9	36	1,5	4 000	43 500	29 000
212-KRR	1,1	60	110	22	30	76,5	94,7	36	1,5	3 700	52 000	36 000

1) With steel cage.

2) $d^{+0,08}_{-0,05}$.

3) $d^{+0,1}$.



Self-aligning deep groove ball bearings

Spherical outer ring
With square or
hexagonal bore

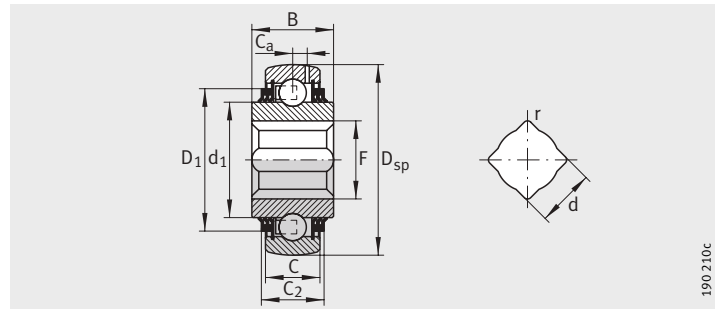

190 210c

GVK..-KTT-B(-AH.), VK..-KTT-B(-AH.)

Dimension table · Dimensions in mm									
Width across flats of shaft d		Designation	Mass m ≈kg	Dimensions					
				d	d	D _{sp}	C	C ₂	d ₁
inch	mm				Deviation				
–	17,0000	SKE17-204-KRR-B	0,12	17,0000	+0,15 +0,05	47	14	–	28,7
7/8	22,2250	SK014-205-KRR-B	0,2	22,2250	+0,15 +0,05	52	15	16,7	33,8
1	25,4000	GVK100-208-KTT-B	0,74	25,4000	+0,9 +0,6	80	21	28,1	52,3
		VK100-208-KTT-B-AH10	0,72	25,4000	+0,9 +0,6	80	18	25,3	52,3
		SK100-206-KRR-B-AH11	0,32	25,4000	+0,15 +0,03	62	16	18,7	40,2
1 1/8	28,5750	GVK102-208-KTT-B-AH10	0,68	28,5750	+0,9 +0,6	80	18	25,3	52,3
		SK102-207-KRR-B-AH10	0,45	28,5750	+0,175 +0,03	72	17	20,5	46,8
1 1/4	31,7500	GVK104-209-KTT-B	0,71	31,7500	+0,9 +0,6	85	22	27,4	57,9
		SK104-207-KRR-B-AH12	0,45	31,7500	+0,2 +0,1	72	17	20,5	46,8
1 9/16	39,6875	GVK109-211-KTT-B	1,25	39,6875	+1,1 +0,8	100	25	29	69,8

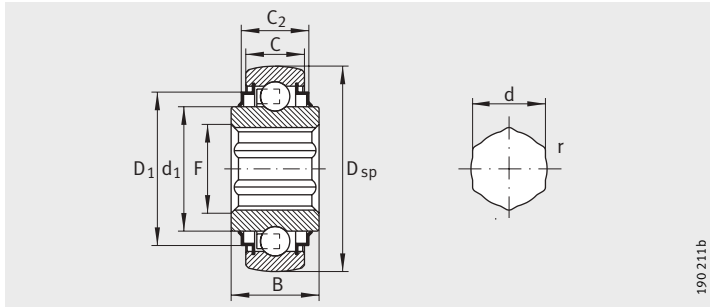

SK..-KRR-B(-AH)

F	D ₁	C _a	B	r	Limiting speed n _G grease min ⁻¹	Basic load ratings		Width across flats of shaft	
						dyn. C _r N	stat. C _{0r} N	d	
								inch	mm
20,2	–	–	17,7	0,13	900	12 800	6 600	–	17,0000
26,2	42,6	–	25,4	0,13	900	14 000	7 800	7/8	22,2250
35,4	68,3	6,4	36,5	2,5	500	32 500	19 800	1	25,4000
35,4	68,3	–	36,5	2,5	500	32 500	19 800		
30,5	52	–	24	0,13	800	19 500	11 300		
41,3	68,3	5,8	36,5	2,5	500	32 500	19 800	1 ¹ / ₈	28,5750
38	60,3	–	37,7	0,25	800	25 500	15 300		
44,3	72,3	6,4	36,5	2,5	500	32 500	20 400	1 ¹ / ₄	31,7500
38	60,3	–	25	0,12	800	25 500	15 300		
55,2	85,9	7,1	36	2,5	450	43 500	29 000	1 ⁹ / ₁₆	39,6875



Self-aligning deep groove ball bearings

Spherical outer ring
Bore for fit

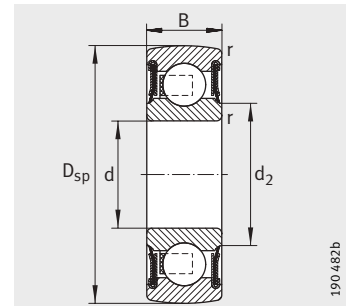

2..-NPP-B

Dimension table · Dimensions in mm									
Designation	Mass m ≈ kg	Dimensions					Limiting speed n _G grease min ⁻¹	Basic load ratings	
		d	D _{sp}	B	d ₂	r _{min}		dyn. C _r N	stat. C _{0r} N
201-NPP-B¹⁾	0,04	12	32	10	17,1	0,6	18 300	6 800	3 050
203-NPP-B²⁾	0,06	17	40	12	22,5	0,6	13 000	9 800	4 750
204-NPP-B²⁾	0,11	20	47	14	26,5	1	11 000	12 800	6 600
205-NPP-B²⁾	0,13	25	52	15	30,3	1	8 800	14 000	7 800
206-NPP-B¹⁾	0,2	30	62	16	37,4	1	7 300	19 500	11 300
207-NPP-B¹⁾	0,29	35	72	17	42,4	1	6 300	25 500	15 300
208-NPP-B¹⁾	0,37	40	80	18	48,4	1,1	5 500	32 500	19 800
209-NPP-B¹⁾	0,41	45	85	19	53,2	1,1	4 900	32 500	20 400
210-NPP-B¹⁾	0,46	50	90	20	58,2	1,1	4 400	35 000	23 200

¹⁾ One-piece seal with moulded seal lip.

²⁾ Three-piece P seal.



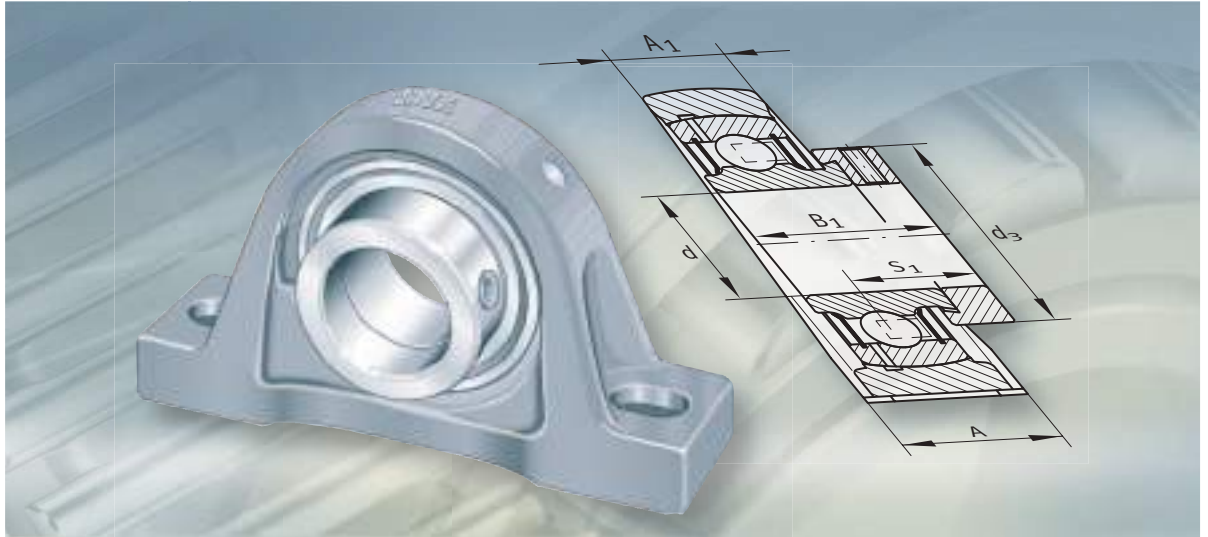

Housing units

Housing units

	Page
Product overview	Housing units 1082
Features	Housing units with cast iron housing 1086
	Housing units with sheet steel housing 1088
	Possible combinations of insert bearings and housings 1089
	Other products 1089
	Suffixes 1089
	Possible combinations – radial insert ball bearings with cast iron housings 1090
	Possible combinations – radial insert ball bearings with sheet steel housings 1092
Design and safety guidelines	Compensation of misalignments 1094
	Load carrying capacity of housings 1095
	Load carrying capacity and speed limits of radial insert ball bearings 1095
	Design of adjacent construction 1096
	Bearing end caps 1096
Fitting and dismantling	Delivered condition 1097
	Storage/storage period 1097
	Removal from packaging 1097
	Guidelines for fitting 1097
	Fitting of plated components 1097
	Fitting of cast iron units – plummer block and flanged housing units 1098
	Fitting of cast iron units – radial insert ball bearings with integral adapter sleeve 1100
	Fitting of bearing end caps 1102
	Fitting of sheet steel units with eccentric locking collar/ grub screws in inner ring 1103
Accuracy	Cast iron housings 1105
	Sheet steel housings 1105
Dimension tables	Plummer block housing units (cast iron housings) 1106
	Flanged housing units (cast iron housings) 1120
	Take-up housing units (cast iron housings, sheet steel housings) 1150
	Plummer block housing units (sheet steel housings) 1160
	Flanged housing units (sheet steel housings) 1162



Product overview Housing units

Plummer block housing units

Cast iron housings with long base

Combinations
of bearings and housings
see page 1090

PASE, PASEY, RASE, RASEL, RASEA, RASEY, TASE, LASE, RSAO, RASEY..-JIS

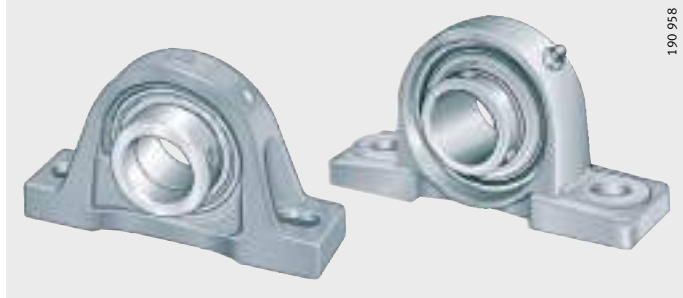

Cast iron housings with short base

PSHE, PSHEY, RSHE, RSHEY, TSHE



Two-bolt flanged housing units

Cast iron housings

Combinations
of bearings and housings
see page 1090

PCJT, PCJTY, RCJTZ, RCJT, RCJTA, RCJTY, PCFT, TCJT, LCJT, RCJTY..-JIS

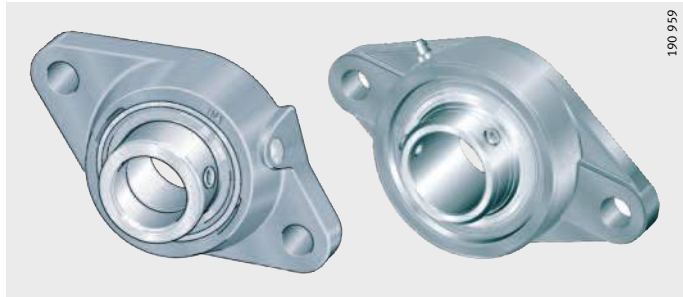

FLCTE, FLCTEY, GLCTE



**Three-bolt
flanged housing units**

Cast iron housings

Combinations
of bearings and housings
see page 1090

PCFTR

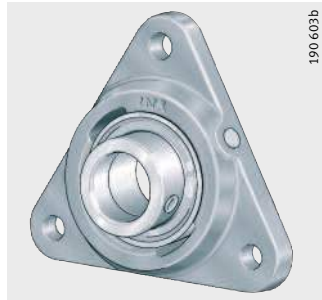

**Four-bolt
flanged housing units**

Cast iron housings

Combinations
of bearings and housings
see page 1090

PCJ, PCJY, RCJ, RCJY, RCJL, RCJO, TCJ, PCF, RCJY..-JIS

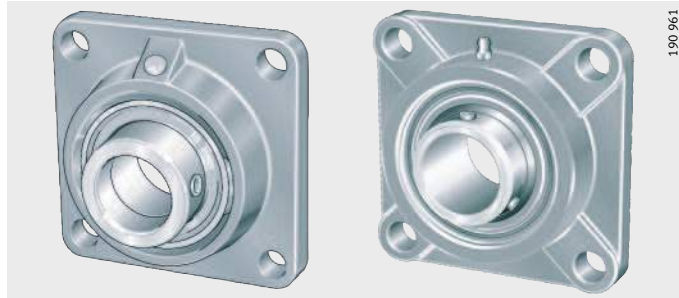

**PME, PMEY, RME, RMEY,
RME0, TME**



RFE, TFE



PCCJ



Product overview Housing units

Take-up housing units

Cast iron housings

Combinations
of bearings and housings
see page 1091

**PTUE, PTUEY, RTUE, RTUEY,
RTUEO, TTUE**

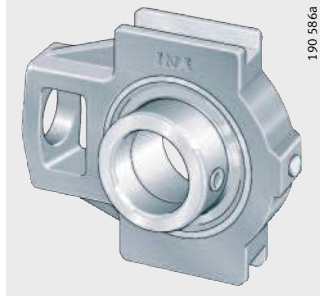

PHE, PHEY, RHE, THE

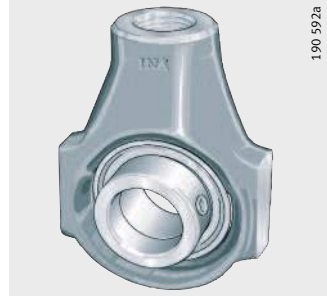

PSFT



Sheet steel housings

MSTU



Cast iron/sheet steel housings

PHUSE

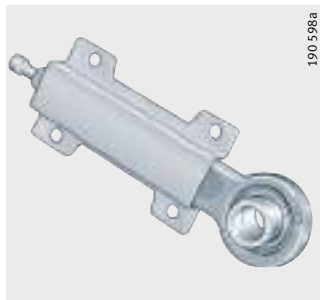

Plummer block housing units

Sheet steel housings

Combinations
of bearings and housings
see page 1092

PBS



PB, PBY, RPB



**Two-bolt and three-bolt
flanged housing units**

Sheet steel housings

Combinations
of bearings and housings
see page 1092

RAT, RATY, RALT, PCSLT

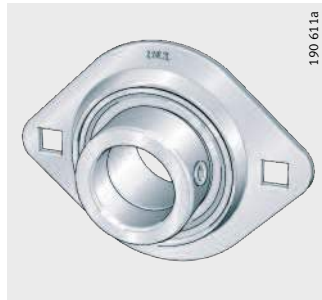

RCSMF



RATR, RALTR, RRTR, RATRY

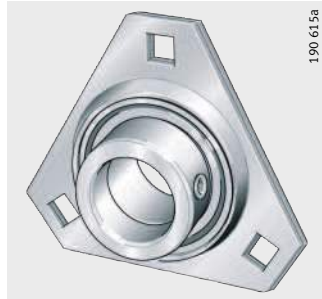

RA, RAY, RRY, GRA, GRRY



Housing units

Features INA housed bearing units are available as plummer block, flanged and take-up housing units in numerous different designs. The units are ready-to-fit and comprise INA cast iron or sheet steel housings in which INA radial insert ball bearings are fitted. In order to ensure function and reliability under all operating conditions, the bearings and housings are matched to each other.

Due to the spherical outside surface of the bearing outer ring and the concave housing bore, housing units can compensate for static angular misalignment of the shaft; see Compensation of misalignments, page 1094.

The units are used predominantly as locating bearings, but are also suitable as non-locating bearings under low loads and speeds.

The housings are screw mounted on the adjacent construction. Less stringent tolerances are adequate for the screw mounting surfaces; see Design of adjacent construction, page 1096.

Housing units with cast iron housing

Cast iron housings are single-piece units with high load carrying capacity; see Load carrying capacity of cast iron housings, page 1095. For lubrication of radial insert ball bearings, the housing bore has a radial groove and the housing has a lubrication hole suitable for conventional lubrication nipples to DIN 71 412. In the delivered condition, the hole in the housing is closed off by a plastic plug. Cast iron units are available as plummer block and flanged housing units.

Plummer block housing units

Plummer block housing units have a long or a short base, *Figure 1*. Housings with a long base are screw mounted to the adjacent construction by means of slots, housings with a short base by blind threaded holes.

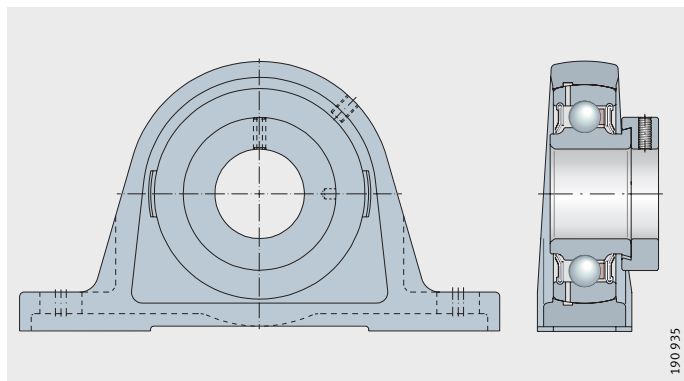

Figure 1

Plummer block housing unit – cast iron housing with long base

Flanged housing units

Flanged housing units are available as two-bolt, three-bolt and four-bolt units, *Figure 2*. The housings are oval, triangular, square or round in shape. The housings have through holes for locating purposes. Some series also have a centring spigot. The centring spigot is mounted in a turned recess in the machine structure. This gives concentric alignment of the housings and relieves the fixing screws of any radial forces.

PCJT

Figure 2

Flanged housing unit – cast iron housing

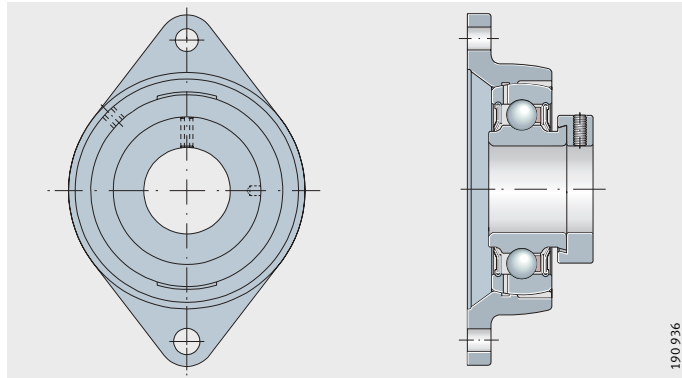

Take-up housing units

Take-up housing units can be moved or swivelled, *Figure 3*. They are used where shafts must carry out long displacement motions.

PTUE

Figure 3

Take-up housing unit – cast iron housing

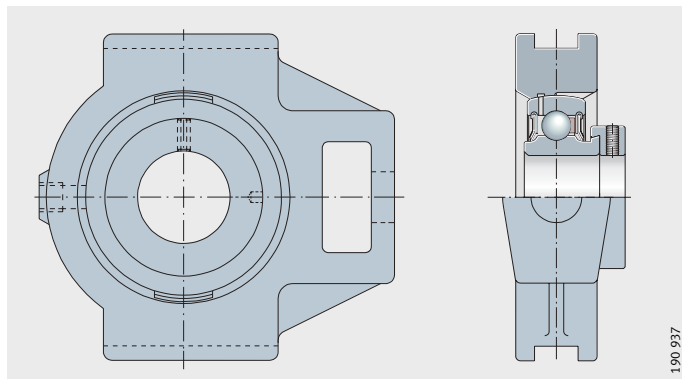

Housing materials

The material used for the cast iron housings is cast iron to EN-GJL-200/250. Housings are also available by agreement in spheroidal graphite cast iron to EN-GJS-400/450.

Bearing end caps

In order to cover the exposed ends of rotating shafts, cast iron housings with the suffix N can be fitted with bearing end caps.

Housing units

Corrosion-resistant units

Corrosion-resistant units are available as plummer block and flanged housing units. The housings and insert bearings are plated with Corrotect® and have the suffix FA125.

The units are used if moisture, contaminated water, salt spray mist, weakly alkaline or weakly acidic cleaning agents are present.

Units for high and low temperatures

These units are available as plummer block and flanged housing units. The housings correspond to the cast iron housings described above. The high temperature variant FA164 includes a tapered lubrication nipple to DIN 71412 screwed into the housing.

The radial insert ball bearings fitted have the suffix FA164 or FA101 and are designed for high or low temperatures; see Radial insert ball bearings, page 1037.

Housing units with sheet steel housing

Sheet steel housings are two-piece units made from pressed deep drawn sheet steel and are in some cases plated with Corrotect®. Series GRA and GRRY can be relubricated via a lubrication nipple. The units are available as plummer block and flanged housing units, *Figure 4* and *Figure 5*.

Units with sheet steel housings are suitable for moderate loads and lightweight constructions.

Plummer block and flanged housing units with rubber interliner

In addition to the normal plummer block and flanged housing units, there is also a design with a rubber interliner on the bearing outer ring. This interliner absorbs shocks and vibrations and thus gives damping of running noises.

PB

Figure 4

Plummer block housing unit – sheet steel housing

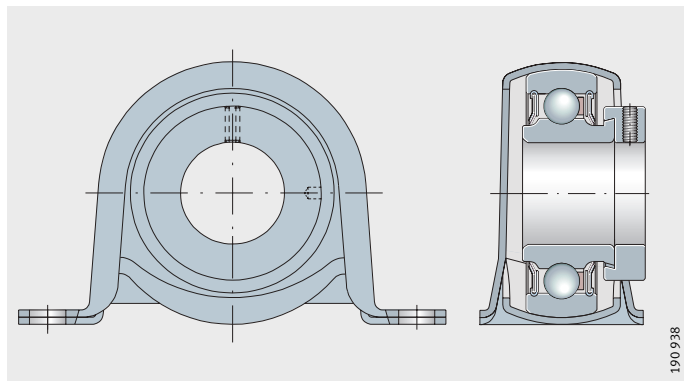

GRA

Figure 5

Flanged housing unit – sheet steel housing

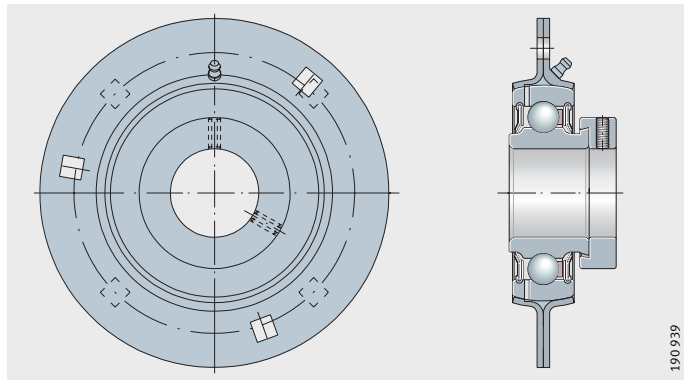

Corrosion-resistant units The two-piece sheet steel flanged units have the suffix VA and are also available with a relubrication facility. They are used if moisture, contaminated water, salt spray mist, weakly alkaline or weakly acidic cleaning agents are present.

Possible combinations of radial insert ball bearings and housings Possible combinations – radial insert ball bearings with sheet steel housings, see page 1090/1092.

Other products In addition to the comprehensive catalogue range, INA also supplies housing units for special applications, including:

- corrosion-resistant flanged housing units with two-piece housings
 - a polypropylene flanged element combined with a corrosion-resistant alloy steel flanged element
- units with plastic housings combined with radial insert ball bearings of type VA
- other designs with special greases, seals etc. Please contact us as necessary.

Suffixes Suffixes for available housing unit designs: see table.

Available designs

Suffixes	Description
2C	Radial insert ball bearing with flinger shields on both sides
FA101	High/low temperature design for –40 °C to +150 °C
FA106	Bearing subjected to special noise testing
FA107	Bearing with lubrication holes on the locating side
FA125	With Corrotect® plating
FA164	High temperature design up to +250 °C
N	Cast iron housing with undercut slot for end caps
OSE	Bearing without locating element
JIS	Housing dimensions according to JIS B 1559

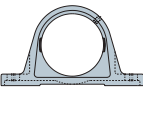
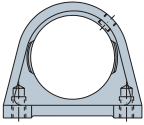
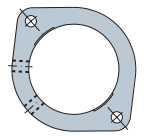
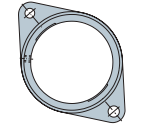
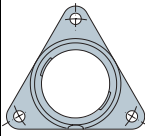
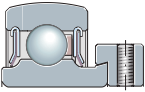
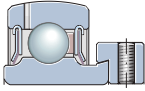
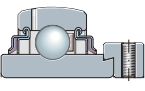
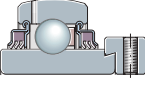
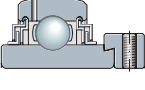
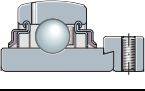
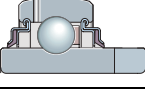
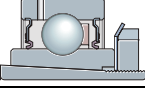
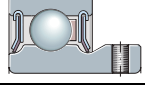
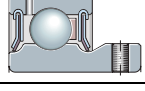
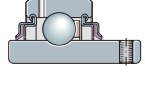

Housing units

Possible combinations – radial insert ball bearings with cast iron housings		Housings					
		Plummer block housings		Two-bolt flanged housings		Three-bolt flanged housings	
							
		GG.ASE	GG.SHE	GG.LCTE²⁾	GG.CJT	GG.CFTR	
GG.SAO¹⁾		GG.GLCTE	GG.CFT				
			GG.CJTZ				
RAE..-NPP-B d = 12 to 50 mm				FLCTE²⁾ page 1120			
GRAE..-NPP-B d = 12 to 60 mm		PASE page 1106	PSHE page 1116	GLCTE page 1120	PCJT page 1122 PCFT page 1122	PCFTR page 1132	
GE..-KRR-B d = 17 to 120 mm		RASE page 1106	RSHE page 1116		RCJT page 1122 RCJTZ page 1130	Available by agreement only	
GE..-KTT-B d = 20 to 80 mm		TASE page 1106	TSHE page 1116		TCJT page 1122	Available by agreement only	
GE..-KLL-B d = 20 to 50 mm		LASE page 1106	Available by agreement only		LCJT page 1122	Available by agreement only	
GNE..-KRR-B¹⁾ d = 30 to 100 mm		RSAO page 1108					
GLE..-KRR-B d = 20 to 70 mm		RASEL page 1106	Available by agreement only		Available by agreement only	Available by agreement only	
GSH..-2RSR-B d = 20 to 50 mm		RASEA page 1106	Available by agreement only		RCJTA page 1122	Available by agreement only	
AY..-NPP-B d = 12 to 30 mm				FLCTEY²⁾ page 1120			
GAY..-NPP-B d = 12 to 60 mm		PASEY page 1106	PSHEY page 1116	FLCTEY²⁾ page 1120	PCJTY page 1122	Available by agreement only	
GYE..-KRR-B d = 12 to 90 mm		RASEY page 1106	RSHEY page 1116		RCJTY page 1122	Available by agreement only	

Catalogue range, for dimension tables see pages indicated.

Other dimensions and combinations available by agreement.

Combinations not possible or not advisable.



Four-bolt flanged housings		Four-bolt flanged housings		Take-up housings		
						
GG.ME	GG.CJ	GG.TUE	GEH.HUE GEH..-HUSE	GG.HE	GG.SFT	GEH..-MSTU
GG.MEO¹⁾	GG.CJO¹⁾	GG.TUEO¹⁾				
GG.FE	GG.CF					
						MSTU page 1158
PME page 1142	PCJ page 1134 PCF page 1134	PTUE page 1150	PHUSE page 1156	PHE page 1154	PSFT page 1158	
RME page 1142 RFE page 1146	RCJ page 1134	RTUE page 1150	Available by agreement only	RHE page 1154	Available by agreement only	Available by agreement only
TME page 1142 TFE page 1146	TCJ page 1134	TTUE page 1150	Available by agreement only	THE page 1154	Available by agreement only	Available by agreement only
Available by agreement only	Available by agreement only	Available by agreement only	Available by agreement only	Available by agreement only	Available by agreement only	Available by agreement only
RMEO page 1142	RCJO page 1136	RTUEO page 1152				
Available by agreement only	RCJL page 1136	Available by agreement only	Available by agreement only	Available by agreement only	Available by agreement only	Available by agreement only
Available by agreement only	Available by agreement only	Available by agreement only	Available by agreement only	Available by agreement only	Available by agreement only	Available by agreement only
						Available by agreement only
PMEY page 1142	PCJY page 1134	PTUEY page 1150	Available by agreement only	PHEY page 1154	Available by agreement only	
RMEY page 1142	RCJY page 1134	RTUEY page 1150	Available by agreement only	Available by agreement only	Available by agreement only	Available by agreement only



1) Heavy series.

2) Without lubrication hole.

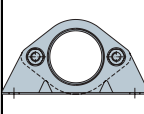
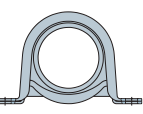
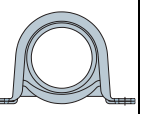
Housing units

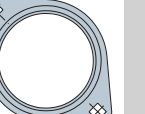
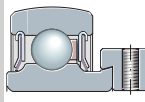
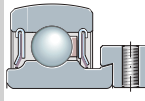
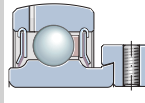
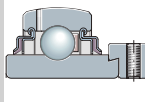
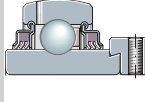
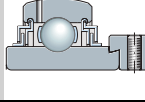
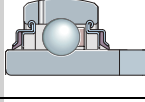
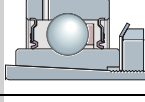
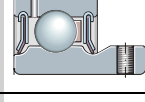
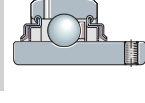
Possible combinations – radial insert ball bearings with sheet steel housings		Housings				
		Plummer block housings			Two-bolt flanged housings	
						
GEH...PBS	GEH...BT	GEH...BT GRG...RABR	FLAN...LST (2 pieces)	FLAN...MST (2 pieces)		
RALE...NPP-B d = 20 to 30 mm				RPB page 1160	RALT page 1162	
RAE...NPP-B d = 12 to 40 mm		PBS page 1160	PB page 1160	RPB page 1160		RAT page 1162
GRAE...NPP-B d = 20 to 60 mm						
GE...KRR-B d = 17 to 60 mm		Housing and bearing to be ordered separately	Housing and bearing to be ordered separately	Housing and bearing to be ordered separately		Housing and bearing to be ordered separately
GE...KIT-B d = 20 to 60 mm		Housing and bearing to be ordered separately	Housing and bearing to be ordered separately			Housing and bearing to be ordered separately
GE...KLL-B d = 20 to 50 mm		Housing and bearing to be ordered separately	Housing and bearing to be ordered separately			Housing and bearing to be ordered separately
GLE...KRR-B d = 20 to 60 mm		Housing and bearing to be ordered separately	Housing and bearing to be ordered separately			Housing and bearing to be ordered separately
GSH...2RSR-B d = 20 to 50 mm		Housing and bearing to be ordered separately	Housing and bearing to be ordered separately			Housing and bearing to be ordered separately
(G)AY...NPP-B d = 12 to 60 mm		Housing and bearing to be ordered separately	PBY page 1160			RATY page 1162
GYE...KRR-B d = 12 to 60 mm		Housing and bearing to be ordered separately	Housing and bearing to be ordered separately			Housing and bearing to be ordered separately

Catalogue range, for dimension tables see pages indicated.

Other dimensions and combinations available by agreement.

Combinations not possible or not advisable.

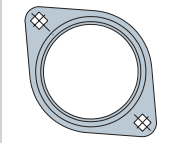
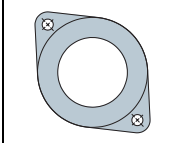
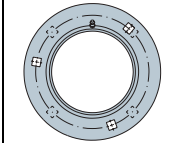
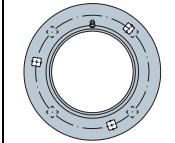
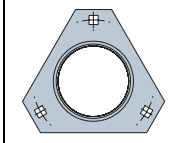
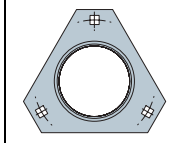
Three-bolt flanged housings					
					
FLAN..-CSLT FLAN..-CST	FLAN..-RCSMF GRG..-RCSM	FLAN..-MSB (2 pieces)	FLAN..-MSA FLAN..-MSB	FLAN..-LSTR (2 pieces)	FLAN..-MSTR (2 pieces)
PCSLT page 1162				RALTR page 1166	
	RCSMF page 1164	RA page 1168			RATR page 1166
		RA page 1168	GRA page 1168		
		Housing and bearing to be ordered separately	Housing and bearing to be ordered separately		RRTR page 1166
		Housing and bearing to be ordered separately	Housing and bearing to be ordered separately		Housing and bearing to be ordered separately
		Housing and bearing to be ordered separately	Housing and bearing to be ordered separately		Housing and bearing to be ordered separately
		Housing and bearing to be ordered separately	Housing and bearing to be ordered separately		Housing and bearing to be ordered separately
		Housing and bearing to be ordered separately	Housing and bearing to be ordered separately		Housing and bearing to be ordered separately
		RAY page 1168			RATRY page 1166
		RRY page 1168	GRRY page 1168		Housing and bearing to be ordered separately



Housing units

Design and safety guidelines

INA radial insert ball bearings and housings are matched to each other and, as a unit, give particularly robust and economical bearing arrangements.

Compensation of misalignments

Units with a spherical outer ring and concave housing bore can compensate for static misalignment of the shaft, *Figure 6*:

- if relubrication is used, up to $\pm 2,5^\circ$
- if relubrication is not used, up to $\pm 5^\circ$.

Caution! The units must not be used to support swivelling or tumbling motion.

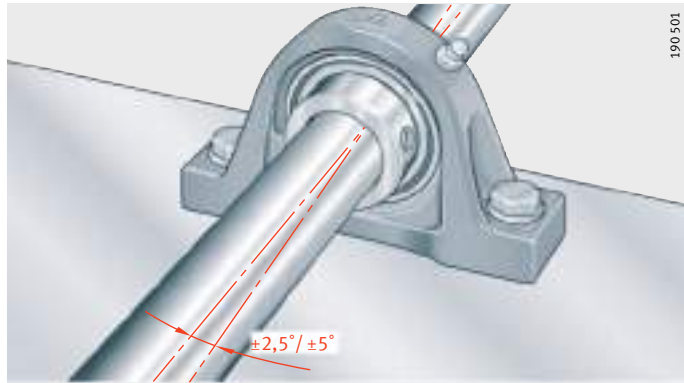

Figure 6
Compensation
of static shaft misalignment

Load carrying capacity of housings

Caution!

Due to their versatile characteristics, INA housed bearing units can be easily used in almost all industrial sectors. If bearing arrangements are planned for equipment in which a malfunction could be hazardous to persons or an unplanned stoppage of the machine could cause major disruption, it is essential that you consult us before proceeding with the design.

Cast iron housings – radial load carrying capacity

Cast iron housings can support the same radial loads as the radial insert ball bearings fitted. The static load carrying capacity of radial insert ball bearings C_{0r} is stated in the dimension tables.

For shock loads, appropriate safety factors must be applied. In this case, please contact us.

Caution!

In the case of TUE and TUEO, the maximum radial tensile loading is only $0,25 \times C_{0r}$ (for higher loads, please contact us).

Axial load carrying capacity

The axial load carrying capacity of cast iron housings is restricted to $0,50 \times C_{0r}$.

Sheet steel housings – radial load carrying capacity

Sheet steel housings are suitable for moderate loads.

The permissible radial load carrying capacity C_{0rG} is given in the dimension tables.

Axial load carrying capacity

The permissible axial load carrying capacity of sheet steel housings is shown in the table.

Permissible axial load carrying capacity

Units with sheet steel housings	Permissible axial load carrying capacity ¹⁾
MSTU	$0,20 \times C_{0rG}$
PHUSE	$0,25 \times C_{0rG}$
PB, PBY, RPB	$0,33 \times C_{0rG}$
PBS	$0,20 \times C_{0rG}$
RALTR, RATR, RATRY, RRTR	$0,50 \times C_{0rG}$
PCSLT, RAT, RATY, RALT	$0,50 \times C_{0rG}$
RCSMF	$0,33 \times C_{0rG}$
RA, RAY, GRA, RRY, GRRY	$0,50 \times C_{0rG}$

¹⁾ C_{0rG} is the permissible radial load carrying capacity of the sheet steel housing according to the dimension table.



Load carrying capacity and speed limits of radial insert ball bearings

Caution!

In the design of housing units, attention must be paid to the load carrying capacity and speed limits of the radial insert ball bearings fitted:

- axial load carrying capacity, see page 1048
- speed limits, see page 1049
- dimension tables.

Housing units

Design of adjacent construction

The permissible shaft tolerance is dependent on the speed, load and the insert bearing fitted. Shafts of tolerance zone h6 to h9 can be used. Conventional drawn shafts will suffice for most applications.

Screw mounting surfaces

Recommendations for the screw mounting surfaces:

- roughness of the screw mounting surface max. $R_a 12,5$ ($R_z 63$)
- geometrical tolerance 0,04/100 concave, spherical not permissible.

Fixing screws

The screw connection should be designed according to VDI 2230; friction value $\mu = 0,14$. Screws of grade 8.8 or better can be used. For fixing, hexagonal socket head screws to DIN EN ISO 4 762 should be used. The screws should be secured by at least a washer to DIN EN ISO 7 089/7 090 or additionally with a lock washer to DIN 128 or a conical spring washer to DIN 6 796.

The screws are not included in the delivery.

Bearing end caps

In order to cover the shaft ends, bearing end caps made from plastic (acrylic ester rubber) are available, table, *Figure 7*. The caps are suitable for temperatures from -20 °C to $+80\text{ °C}$. They protect against injury due to rotating shafts and also protect the bearings against contamination.

For fixing of the caps, housings with the suffix N have an annular groove on the side with the locating slot. Fitting of the caps is described on page 1102.

The series for which end caps are supplied are indicated in the dimension tables. Bearing end caps are accessories and must always be ordered separately.

End caps

Bearing end caps Designation	Dimensions			
	d	D	L	E max.
KASK04	20	48	36	30
KASK05	25	54	38	30
KASK06	30	63	44	35
KASK07	35	73	47	39
KASK08	40	82	51	42
KASK10	50	92	56	46
KASK12	60	112	65	55

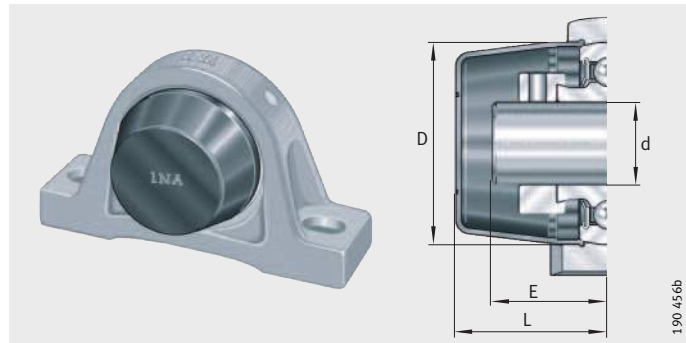

Figure 7

Plummer block housing unit with bearing end cap

Fitting and dismantling Radial insert ball bearings must be handled with care before and during assembly. Their trouble-free operation is also dependent on the care taken in fitting.

Delivered condition The housings have a coating of anthracite grey primer (\approx RAL 7016). The radial insert ball bearings are greased; for information on the grease used, see table Features of radial insert ball bearings – comparison of series, page 1046.

Storage/storage period The units should be stored:
■ in dry, clean rooms with the temperature as constant as possible
■ at a maximum relative humidity of max. 65%.
The storage period of radial insert ball bearings is limited by the storage life of the grease, see section Lubrication.

Removal from packaging Perspiration causes corrosion. Hands should be kept clean and dry. Bearings should not be removed from their original packaging until immediately before assembly.

Guidelines for fitting

Caution! If cast iron housings and bearings are not supplied by INA as ready-to-fit units but are instead combined by the customer, the following guidelines should be followed:

- if the fit is too loose, grease can escape between the housing and bearing and will not therefore reach the bearing during relubrication
- if the fit is too tight, the bearing outer ring cannot align itself within the housing bore.

The assembly area should be as dry and clean as possible.

First, bolt the housing to the adjacent construction, then locate the inner bearing ring on the shaft – if this sequence is followed, the bearing will align itself to the shaft such that stresses do not occur.

Provide the fitting tools and fixing screws.

Clean the shaft and remove any burrs.

Inspect the bearing seating surfaces on the shaft.

Keep bearing seating surfaces clean, dry and free of grease.

Caution! The specified tolerances must be observed.

Fitting forces must never be directed through the rolling elements.

Blows must never be applied directly to the bearing rings and seals.

Fitting of plated components

Before fitting, the compatibility of products plated with Corrotect[®] with the media should be checked.

The tolerances are increased by the thickness of the plating.

In order to reduce the forces involved in pressing-in, the surface of the parts should be lightly greased or a mounting paste used.



Housing units

Fitting of cast iron units – plummer block and flanged housing units

Push the housing unit onto the shaft and align it with the fixing holes in the adjacent construction, *Figure 8*.

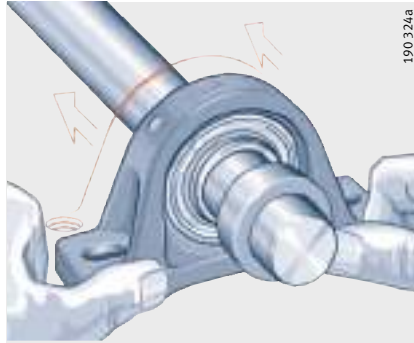

Figure 8
Pushing the unit onto the shaft

Mount the housing on the adjacent construction using the fixing screws, *Figure 9*.

If the shaft is to be supported by several housing units, tighten the screws finger tight at first, align the shaft and then tighten the screws securely.

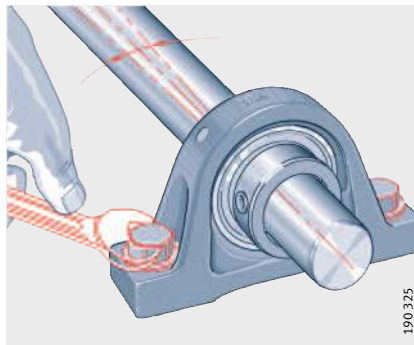

Figure 9
Screw mounting
the housing finger tight

Slide the eccentric locking collar onto the collar seating on the bearing inner ring and rotate by hand, preferably in the direction of shaft rotation, *Figure 10*.

Using a drift and hammer, tension the eccentric locking collar by means of one or two strong blows, *Figure 10*.

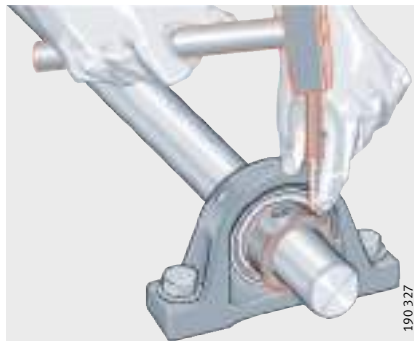

Figure 10
Tensioning
the eccentric locking collar

For location using a locking collar, tighten the grub screw by means of a torque wrench, *Figure 11*.

For location using grub screws in the inner ring, tighten both grub screws by means of a torque wrench.

Caution! Observe the tightening torque M_A according to the table.

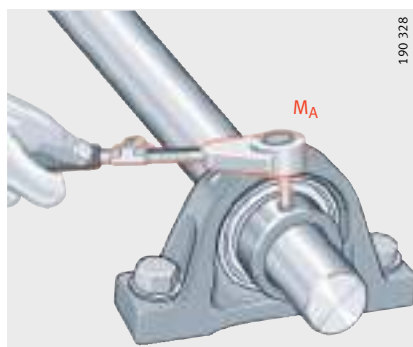

Figure 11
Tightening the grub screw
in the eccentric locking collar or
inner ring

Dismantling

For bearings with an eccentric locking collar, undo the grub screw and rotate the locking collar in the opposite direction to the direction of shaft rotation.

For bearings with grub screws in the inner ring, undo both grub screws.

Unbolt the housing.

Tightening torques for grub screws

Width across flats A/F mm	Thread	Tightening torque ¹⁾ M_A Nm
2,5	M5	3,6
3	M6×0,75	6
4	M8×1	14
5	M10×1,25	26
6	M12, M12×1,25 ²⁾	42

¹⁾ The tightening torques are valid for original INA grub screws only.

²⁾ GYE90-KRR-B.



Housing units

Fitting of cast iron units – radial insert ball bearings with integral adapter sleeve

The bearing seatings on the shaft and outside surface of the adapter must be dry and free of grease.

Push the housing unit onto the shaft and align it with the fixing holes in the adjacent construction, *Figure 12*.

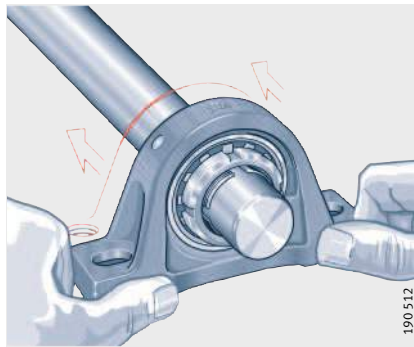

Figure 12

Pushing the unit onto the shaft

Mount the housing on the adjacent construction using the fixing screws, *Figure 13*. If the shaft is to be supported by several housing units, tighten the screws finger tight at first, align the shaft and then tighten the screws securely.

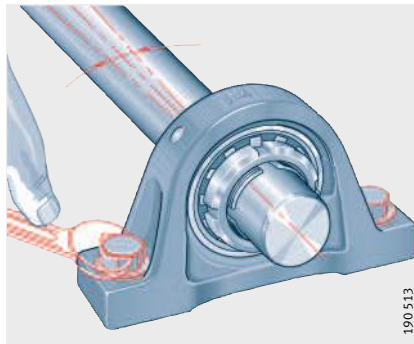

Figure 13

Screw mounting the housing finger tight

Tighten the locknut using 2 hook wrenches of type A to DIN 1810-5; for tightening, the adapter sleeve must be located using a second hook wrench, *Figure 14*. Wrenches for tightening and counter-tensioning: see table.

Caution! Do not exceed the maximum tightening torque M_A given in the table, otherwise the operating clearance in the bearing will become too small. Driving the locknut up will slightly displace the bearing in an axial direction.

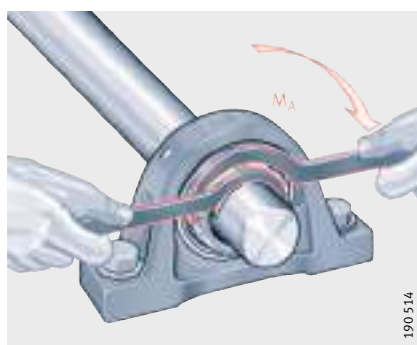

Figure 14
Tightening of locknut

Bend the tab on the tab washer into a groove in the locknut to secure the nut against loosening, *Figure 15*.

Caution! Ensure that the seal in the bearing is not damaged when bending the locking tab over.

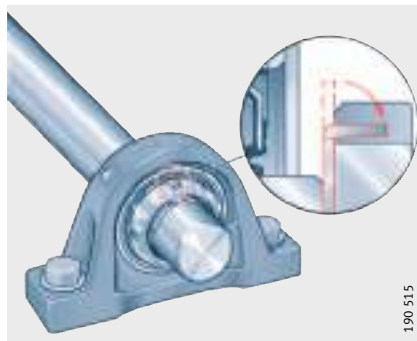

Figure 15
Securing of locknut

Dismantling

Bend back the tab on the tab washer and undo the locknut by a few turns. Place the impact cap in front of the locknut and drive the adapter sleeve off the shaft seat using hammer blows. Unbolt the housing.

Hook wrenches and tightening torques

Shaft diameter d mm	Hook wrench, type A, to DIN 1810 A		Tightening torque Locknut	
	For tightening locknut	For countertensioning adapter sleeve	$M_{A \text{ min}}$ Nm	$M_{A \text{ max}}$ Nm
20	A 30–32 (HN 4)	A 25–28 (HN 2)	13	17
25	A 40–42 (HN 5)	A 30–32 (HN 3)	22	28
30	A 45–50 (HN 6)	A 34–36 (HN 4)	33	40
35	A 52–55 (HN 7)	A 40–42 (HN 5)	47	56
40	A 58–62 (HN 8)	A 45–50 (HN 6)	70	80
50	A 68–75 (HN 10)	A 52–55 (HN 7)	90	105



Housing units

Fitting of bearing end caps

Description of bearing end caps: see page 1096.

Caution!

Bearing end caps should only be fitted or dismantled while the shaft is stationary. If the shaft is rotating, there is a high risk of injury.

Position the tabs of the end cap in the locating slots, noting the position of the INA logo, *Figure 16*.

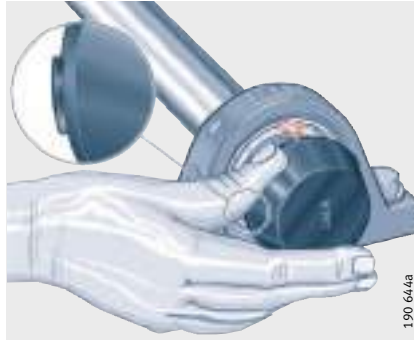

Figure 16
Positioning the cap

Rotate the end cap clockwise by 90°, noting the position of the INA logo, *Figure 17*. Check that the end cap is secured properly in the housing.

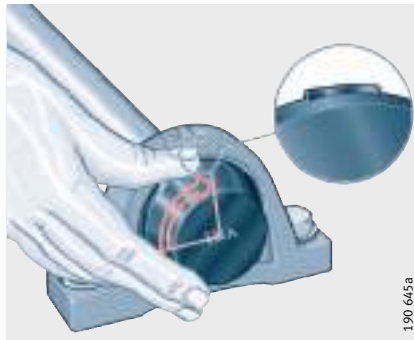

Figure 17
Locking the cap in place

Dismantling

Loosen the end cap by rotating it in the opposite direction (90°), noting the position of the INA logo, *Figure 18*.

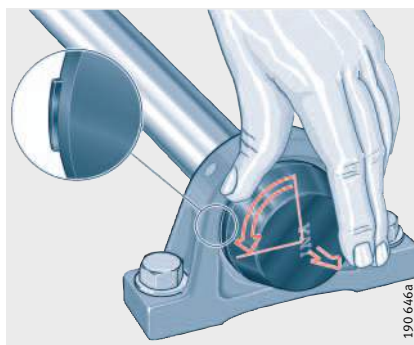

Figure 18
Removing the cap

Fitting of sheet steel units with eccentric locking collar/grub screws in inner ring

Caution!

With two-piece housings, the housing and radial insert ball bearing should be assembled first.

Push the housing unit onto the shaft and align it with the fixing holes in the adjacent construction, *Figure 19*.



Figure 19

Pushing the unit onto the shaft

Mount the housing on the adjacent construction using the fixing screws, *Figure 20*. If the shaft is to be supported by several housing units, tighten the screws finger tight at first, align the shaft and then tighten the screws securely.



Figure 20

Screw mounting the housing finger tight



Housing units

Slide the eccentric locking collar onto the collar seating on the bearing inner ring and rotate by hand, preferably in the direction of shaft rotation.

Using a drift and hammer, tension the eccentric locking collar by means of one or two strong blows, *Figure 21*.



Figure 21
Tensioning
the eccentric locking collar

For location using a locking collar, tighten the grub screw by means of a torque wrench, *Figure 22*.

For location using grub screws in the inner ring, tighten both grub screws by means of a torque wrench.

Caution! Observe the tightening torque M_A according to the table, page 1099.

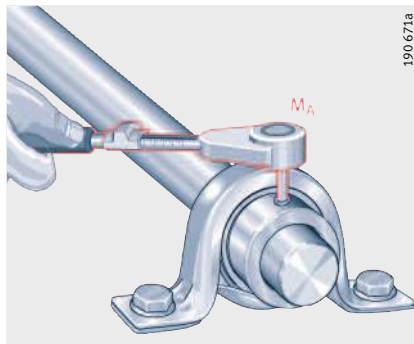

Figure 22
Tightening the grub screw
in the eccentric locking collar or
inner ring

Dismantling

For bearings with an eccentric locking collar, undo the grub screw and rotate the locking collar in the opposite direction to the direction of shaft rotation.

For bearings with grub screws in the inner ring, undo both grub screws.

Unbolt the housing.

- Accuracy** The housings correspond predominantly to DIN 626-2 and ISO 3 228, insofar as they are described therein.
Series with the suffix -JIS are designed in accordance with the “Japanese Industry Standard” JIS B 1559.
Accuracy of fitted radial insert ball bearings: see page 1050.
- Cast iron housings** The dimensional tolerances for the machined surfaces of cast iron housings are $\pm 0,25$ mm.
The dimensional tolerances for unmachined as well as machined to unmachined surfaces correspond to GTB 14 DIN 1 680-2.
For the JIS design, the dimensional tolerances correspond to ISO 8 062/CT10.
- Sheet steel housings** The bearing seat of sheet steel housings is designed such that the bearing is securely seated in the housing when the housing parts are bolted together.



Plummer block housing units

Cast iron housings with long base

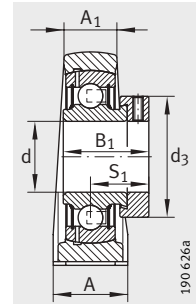
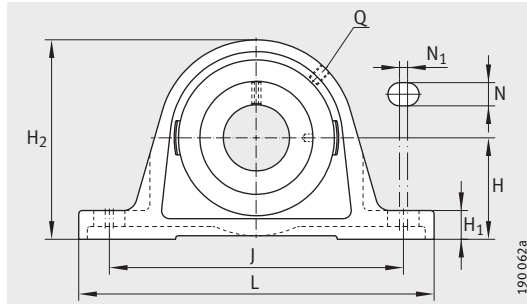

PASE (-FA125), RASE (-FA125, -FA164), TASE, LASE, PASEY, RASEY (-JIS), RASEA, RASEL

PASE

Dimension table · Dimensions in mm									
Designation			Mass m ≈kg	Dimensions					
Unit	Housing	Radial insert ball bearing		d	H	J	L	A	A ₁
PASE12	GG.ASE03	GRAE12-NPP-B	0,46	12	30,2	95	125	30	18
PASEY12	GG.ASE03	GAY12-NPP-B	0,44	12	30,2	95	125	30	18
RASEY12	GG.ASE03	GYE12-KRR-B	0,45	12	30,2	95	125	30	18
PASE15	GG.ASE03	GRAE15-NPP-B	0,46	15	30,2	95	125	30	18
PASEY15	GG.ASE03	GAY15-NPP-B	0,43	15	30,2	95	125	30	18
RASEY15	GG.ASE03	GYE15-KRR-B	0,45	15	30,2	95	125	30	18
RASEY16	GG.ASE03	GYE16-KRR-B	0,45	16	30,2	95	125	30	18
PASE17	GG.ASE03	GRAE17-NPP-B	0,46	17	30,2	95	125	30	18
RASE17	GG.ASE03	GE17-KRR-B	0,5	17	30,2	95	125	30	18
PASEY17	GG.ASE03	GAY17-NPP-B	0,42	17	30,2	95	125	30	18
RASEY17	GG.ASE03	GYE17-KRR-B	0,45	17	30,2	95	125	30	18
PASE20-N	GG.ASE04-E-N	GRAE20-NPP-B	0,55	20	33,3	97	130	32	19
PASE20-N-FA125	GG.ASE04-E-N-FA125.1	GRAE20-NPP-B-FA125.5	0,55	20	33,3	97	130	32	19
RASE20-N	GG.ASE04-E-N	GE20-KRR-B	0,59	20	33,3	97	130	32	19
RASE20-N-FA125	GG.ASE04-E-N-FA125.1	GE20-KRR-B-FA125.5	0,59	20	33,3	97	130	32	19
RASE20-FA164 ¹⁾	GG.ASE04-E-N	GE20-KRR-B-FA164	0,59	20	33,3	97	130	32	19
TASE20-N	GG.ASE04-E-N	GE20-KTT-B	0,59	20	33,3	97	130	32	19
LASE20-N	GG.ASE04-E-N	GE20-KLL-B	0,59	20	33,3	97	130	32	19
PASEY20-N	GG.ASE04-E-N	GAY20-NPP-B	0,52	20	33,3	97	130	32	19
RASEY20-N	GG.ASE04-E-N	GYE20-KRR-B	0,56	20	33,3	97	130	32	19
RASEY20-JIS	GG.P204	GYE20-KRR-B-FA107	0,63	20	33,3	95	127	38	22
RASEA20-N	GG.ASE04-E-N	GSH20-2RSR-B	0,51	20	33,3	97	130	32	19
RASEL20-N	GG.ASE04-E-N	GLE20-KRR-B	0,58	20	33,3	97	130	32	19
PASE25-N	GG.ASE05-N	GRAE25-NPP-B	0,64	25	36,5	103	130	36	21
PASE25-N-FA125	GG.ASE05-N-FA125.1	GRAE25-NPP-B-FA125.5	0,64	25	36,5	103	130	36	21
RASE25-N	GG.ASE05-N	GE25-KRR-B	0,7	25	36,5	103	130	36	21
RASE25-N-FA125	GG.ASE05-N-FA125.1	GE25-KRR-B-FA125.5	0,7	25	36,5	103	130	36	21
RASE25-FA164 ¹⁾	GG.ASE05-N	GE25-KRR-B-FA164	0,7	25	36,5	103	130	36	21
TASE25-N	GG.ASE05-N	GE25-KTT-B	0,7	25	36,5	103	130	36	21
LASE25-N	GG.ASE05-N	GE25-KLL-B	0,7	25	36,5	103	130	36	21
PASEY25-N	GG.ASE05-N	GAY25-NPP-B	0,61	25	36,5	103	130	36	21
RASEY25-N	GG.ASE05-N	GYE25-KRR-B	0,65	25	36,5	103	130	36	21
RASEY25-JIS	GG.P205	GYE25-KRR-B-FA107	0,79	25	36,5	105	140	38	23
RASEA25-N	GG.ASE05-N	GSH25-2RSR-B	0,6	25	36,5	103	130	36	21
RASEL25-N	GG.ASE05-N	GLE25-KRR-B	0,67	25	36,5	103	130	36	21

¹⁾ With lubrication nipple DIN 71412-AR 1/8.

²⁾ To be ordered separately.

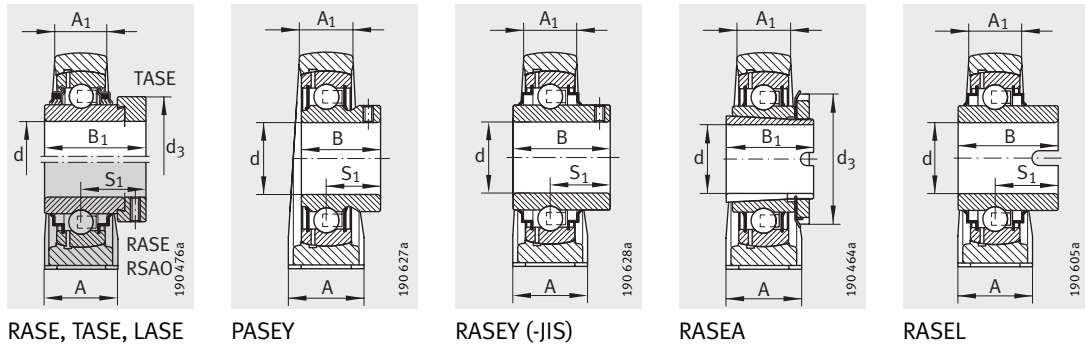

									Basic load ratings		End cap ²⁾
H ₁	H ₂	N	N ₁	B	B ₁	S ₁	Q	d ₃ max.	dyn. C _r N	stat. C _{0r} N	
10	57	11	8	–	28,6	22,1	M6	28	9 800	4 750	–
10	57	11	8	22	–	16	M6	–	9 800	4 750	–
10	57	11	8	27,4	–	15,9	M6	–	9 800	4 750	–
10	57	11	8	–	28,6	22,1	M6	28	9 800	4 750	–
10	57	11	8	22	–	16	M6	–	9 800	4 750	–
10	57	11	8	27,4	–	15,9	M6	–	9 800	4 750	–
10	57	11	8	27,4	–	15,9	M6	–	9 800	4 750	–
10	57	11	8	–	28,6	22,1	M6	28	9 800	4 750	–
10	57	11	8	–	37,4	23,4	M6	28	9 800	4 750	–
10	57	11	8	22	–	16	M6	–	9 800	4 750	–
10	57	11	8	27,4	–	15,9	M6	–	9 800	4 750	–
14,5	64	11	8	–	31	23,5	R _p 1/8	33	12 800	6 600	KASK04
14,5	64	11	8	–	31	23,5	R _p 1/8	33	12 800	6 600	KASK04
14,5	64	11	8	–	43,7	26,6	R _p 1/8	33	12 800	6 600	KASK04
14,5	64	11	8	–	43,7	26,6	R _p 1/8	33	12 800	6 600	KASK04
14,5	64	11	8	–	43,7	26,6	R _p 1/8	33	12 800	6 600	–
14,5	64	11	8	–	43,7	26,6	R _p 1/8	33	12 800	6 600	KASK04
14,5	64	11	8	–	43,7	26,6	R _p 1/8	33	12 800	6 600	KASK04
14,5	64	11	8	25	–	18	R _p 1/8	33	12 800	6 600	KASK04
14,5	64	11	8	31	–	18,3	R _p 1/8	–	12 800	6 600	KASK04
14	65	13	6	31	–	18,3	M6	–	12 800	6 600	–
14,5	64	11	8	–	28	–	R _p 1/8	32	12 700	6 600	KASK04
14,5	64	11	8	34,1	–	18,5	R _p 1/8	–	12 800	6 600	KASK04
14,5	70	11	8	–	31	23,5	R _p 1/8	37,5	14 000	7 800	KASK05
14,5	70	11	8	–	31	23,5	R _p 1/8	37,5	14 000	7 800	KASK05
14,5	70	11	8	–	44,5	26,9	R _p 1/8	37,5	14 000	7 800	KASK05
14,5	70	11	8	–	44,5	26,9	R _p 1/8	37,5	14 000	7 800	KASK05
14,5	70	11	8	–	44,5	26,9	R _p 1/8	37,5	14 000	7 800	–
14,5	70	11	8	–	44,5	26,9	R _p 1/8	37,5	14 000	7 800	KASK05
14,5	70	11	8	–	44,5	26,9	R _p 1/8	37,5	14 000	7 800	KASK05
14,5	70	11	8	27	–	19,5	R _p 1/8	–	14 000	7 800	KASK05
14,5	70	11	8	34,1	–	19,6	R _p 1/8	–	14 000	7 800	KASK05
15	71	13	6	34,1	–	19,8	M6	–	14 000	7 800	–
14,5	70	11	8	–	28	–	R _p 1/8	38	13 600	7 800	KASK05
14,5	70	11	8	34,9	–	20,2	R _p 1/8	–	14 000	7 800	KASK05



Plummer block housing units

Cast iron housings with long base

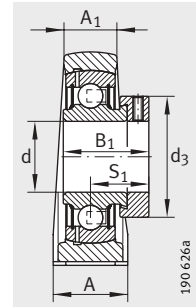
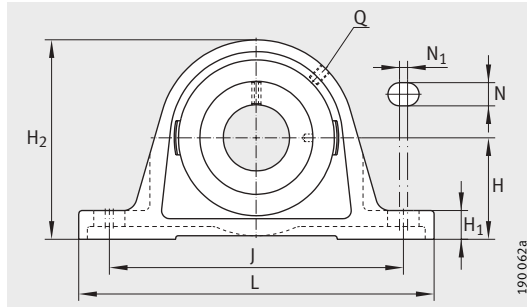

PASE (-FA125), RASE (-FA125, -FA164), TASE, LASE, RSAO, PASEY, RASEY (-JIS), RASEA, RASEL

PASE

Dimension table (continued) · Dimensions in mm

Designation			Mass m ≈kg	Dimensions					
Unit	Housing	Radial insert ball bearing		d	H	J	L	A	A ₁
PASE30-N	GG.ASE06-N	GRAE30-NPP-B	1,04	30	42,9	118	158	40	25
PASE30-N-FA125	GG.ASE06-N-FA125.1	GRAE30-NPP-B-FA125.5	1,04	30	42,9	118	158	40	25
RASE30-N	GG.ASE06-N	GE30-KRR-B	1,11	30	42,9	118	158	40	25
RASE30-N-FA125	GG.ASE06-N-FA125.1	GE30-KRR-B-FA125.5	1,11	30	42,9	118	158	40	25
RASE30-FA164¹⁾	GG.ASE06-N	GE30-KRR-B-FA164	1,11	30	42,9	118	158	40	25
TASE30-N	GG.ASE06-N	GE30-KTT-B	1,12	30	42,9	118	158	40	25
LASE30-N	GG.ASE06-N	GE30-KLL-B	1,11	30	42,9	118	158	40	25
RSAO30	GG.SAO06	GNE30-KRR-B	1,8	30	50	140	180	50	28
PASEY30-N	GG.ASE06-N	GAY30-NPP-B	0,98	30	42,9	118	158	40	25
RASEY30-N	GG.ASE06-N	GYE30-KRR-B	1,06	30	42,9	118	158	40	25
RASEY30-JIS	GG.P206	GYE30-KRR-B-FA107	1,3	30	42,9	121	165	48	26
RASEA30-N	GG.ASE06-N	GSH30-2RSR-B	1	30	42,9	118	158	40	25
RASEL30-N	GG.ASE06-N	GLE30-KRR-B	1,03	30	42,9	118	158	40	25
PASE35-N	GG.ASE06-N	GRAE35-NPP-B	1,53	35	47,6	126	163	45	27
PASE35-N-FA125	GG.ASE07-N-FA125.1	GRAE35-NPP-B-FA125.5	1,53	35	47,6	126	163	45	27
RASE35-N	GG.ASE07-N	GE35-KRR-B	1,6	35	47,6	126	163	45	27
RASE35-N-FA125	GG.ASE07-N-FA125.1	GE35-KRR-B-FA125.5	1,6	35	47,6	126	163	45	27
RASE35-FA164¹⁾	GG.ASE07-N	GE35-KRR-B-FA164	1,6	35	47,6	126	163	45	27
TASE35-N	GG.ASE07-N	GE35-KTT-B	1,61	35	47,6	126	163	45	27
LASE35-N	GG.ASE07-N	GE35-KLL-B	1,6	35	47,6	126	163	45	27
RSAO35	GG.SAO07	GNE35-KRR-B	2,75	35	56	160	210	56	30
PASEY35-N	GG.ASE07-N	GAY35-NPP-B	1,44	35	47,6	126	163	45	27
RASEY35-N	GG.ASE07-N	GYE35-KRR-B	1,54	35	47,6	126	163	45	27
RASEY35-JIS	GG.P207	GYE35-KRR-B-FA107	1,41	35	47,6	127	167	48	27
RASEA35-N	GG.ASE07-N	GSH35-2RSR-B	1,48	35	47,6	126	163	45	27

¹⁾ With lubrication nipple DIN 71412-AR 1/8.

²⁾ To be ordered separately.

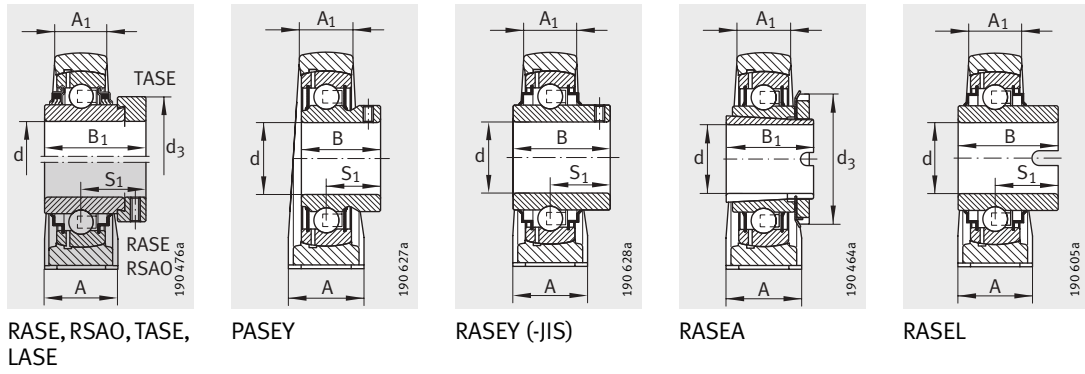

H ₁	H ₂	N	N ₁	B	B ₁	S ₁	Q	d ₃ max.	Basic load ratings		End cap ²⁾
									dyn. C _r N	stat. C _{0r} N	
17	82	14	8	–	35,8	26,7	R _p 1/8	44	19 500	11 300	KASK06
17	82	14	8	–	35,8	26,7	R _p 1/8	44	19 500	11 300	KASK06
17	82	14	8	–	48,5	30,1	R _p 1/8	44	19 500	11 300	KASK06
17	82	14	8	–	48,5	30,1	R _p 1/8	44	19 500	11 300	KASK06
17	82	14	8	–	48,5	30,1	R _p 1/8	44	19 500	11 300	–
17	82	14	8	–	48,5	30,1	R _p 1/8	44	19 500	11 300	KASK06
17	82	14	8	–	48,5	30,1	R _p 1/8	44	19 500	11 300	KASK06
18	95	17,5	3	–	50	32,5	R _p 1/8	51	29 500	16 700	–
17	82	14	8	30	–	21	R _p 1/8	–	19 500	11 300	KASK06
17	82	14	8	38,1	–	22,2	R _p 1/8	–	19 500	11 300	KASK06
17	83	17	4	38,1	–	22,2	M6	–	19 500	11 300	–
17	82	14	8	–	32	–	R _p 1/8	45	18 900	11 300	KASK06
17	82	14	8	36,5	–	22,5	R _p 1/8	–	19 500	11 300	KASK06
19	93	14	7	–	39	29,4	R _p 1/8	51	25 500	15 300	KASK07
19	93	14	7	–	39	29,4	R _p 1/8	51	25 500	15 300	KASK07
19	93	14	7	–	51,3	32,3	R _p 1/8	51	25 500	15 300	KASK07
19	93	14	7	–	51,3	32,3	R _p 1/8	51	25 500	15 300	KASK07
19	93	14	7	–	51,3	32,3	R _p 1/8	51	25 500	15 300	–
19	93	14	7	–	51,3	32,3	R _p 1/8	51	25 500	15 300	KASK07
19	93	14	7	–	51,3	32,3	R _p 1/8	51	25 500	15 300	KASK07
20	106	17,5	8	–	51,6	33,4	R _p 1/8	55	36 500	20 900	–
19	93	14	7	35	–	25,5	R _p 1/8	–	25 500	15 300	KASK07
19	93	14	7	42,9	–	25,4	R _p 1/8	–	25 500	15 300	KASK07
18	93	17	4	42,9	–	25,4	M6	–	25 500	15 300	–
19	93	14	7	–	34	–	R _p 1/8	52	24 900	15 300	KASK07



Plummer block housing units

Cast iron housings with long base

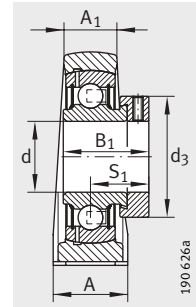
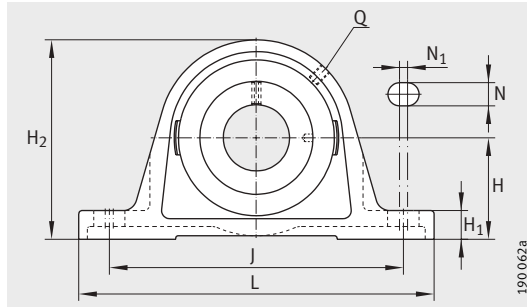

PASE (-FA125), RASE (-FA125, -FA164), TASE, LASE, RSAO, PASEY, RASEY (-JIS), RASEA, RASEL

PASE

Dimension table (continued) · Dimensions in mm									
Designation			Mass	Dimensions					
Unit	Housing	Radial insert ball bearing	m	d	H	J	L	A	A ₁
			≈kg						
PASE40-N	GG.ASE/AK08-N	GRAE40-NPP-B	1,71	40	49,2	138	179	48	30
PASE40-N-FA125	GG.ASE/AK08-N-FA125.1	GRAE40-NPP-B-FA125.5	1,71	40	49,2	138	179	48	30
RASE40-N	GG.ASE/AK08-N	GE40-KRR-B	1,83	40	49,2	138	179	48	30
RASE40-N-FA125	GG.ASE/AK08-N-FA125.1	GE40-KRR-B-FA125.5	1,83	40	49,2	138	179	48	30
RASE40-FA164¹⁾	GG.ASE/AK08-N	GE40-KRR-B-FA164	1,83	40	49,2	138	179	48	30
TASE40-N	GG.ASE/AK08-N	GE40-KTT-B	1,86	40	49,2	138	179	48	30
LASE40-N	GG.ASE/AK08-N	GE40-KLL-B	1,83	40	49,2	138	179	48	30
RSAO40	GG.SAO08	GNE40-KRR-B	3,18	40	60	170	220	60	31
PASEY40-N	GG.ASE/AK08-N	GAY40-NPP-B	1,6	40	49,2	138	179	48	30
RASEY40-N	GG.ASE/AK08-N	GYE40-KRR-B	1,74	40	49,2	138	179	48	30
RASEY40-JIS	GG.P208	GYE40-KRR-B-FA107	1,68	40	49,2	137	184	54	30
RASEA40-N	GG.ASE/AK08-N	GSH40-2RSR-B	1,71	40	49,2	138	179	48	30
RASEL40-N	GG.ASE/AK08-N	GLE40-KRR-B	1,7	40	49,2	138	179	48	30
PASE45	GG.ASE09	GRAE45-NPP-B	2,09	45	54	150	192	48	32
PASE45-FA125	GG.ASE09-FA125.1	GRAE45-NPP-B-FA125.5	2,09	45	54	150	192	48	32
RASE45	GG.ASE09	GE45-KRR-B	2,21	45	54	150	192	48	32
RASE45-FA125	GG.ASE09-FA125.1	GE45-KRR-B-FA125.5	2,21	45	54	150	192	48	32
TASE45	GG.ASE09	GE45-KTT-B	2,26	45	54	150	192	48	32
LASE45	GG.ASE09	GE45-KLL-B	2,21	45	54	150	192	48	32
PASEY45	GG.ASE09	GAY45-NPP-B	1,95	45	54	150	192	48	32
RASEY45	GG.ASE09	GYE45-KRR-B	2,1	45	54	150	192	48	32
RASEY45-JIS	GG.P209	GYE45-KRR-B-FA107	2,07	45	54	146	190	54	30
RASEL45	GG.ASE09	GLE45-KRR-B	2,1	45	54	150	192	48	32
PASE50-N	GG.ASE10-N	GRAE50-NPP-B	2,47	50	57,2	158	200	54	34
PASE50-N-FA125	GG.ASE10-N-FA125.1	GRAE50-NPP-B-FA125.5	2,47	50	57,2	158	200	54	34
RASE50-N	GG.ASE10-N	GE50-KRR-B	2,7	50	57,2	158	200	54	34
RASE50-N-FA125	GG.ASE10-N-FA125.1	GE50-KRR-B-FA125.5	2,7	50	57,2	158	200	54	34
RASE50-FA164¹⁾	GG.ASE10-N	GE50-KRR-B-FA164	2,7	50	57,2	158	200	54	34
TASE50-N	GG.ASE10-N	GE50-KTT-B	2,76	50	57,2	158	200	54	34
LASE50-N	GG.ASE10-N	GE50-KLL-B	2,7	50	57,2	158	200	54	34

¹⁾ With lubrication nipple DIN 71412-AR 1/8.

²⁾ To be ordered separately.

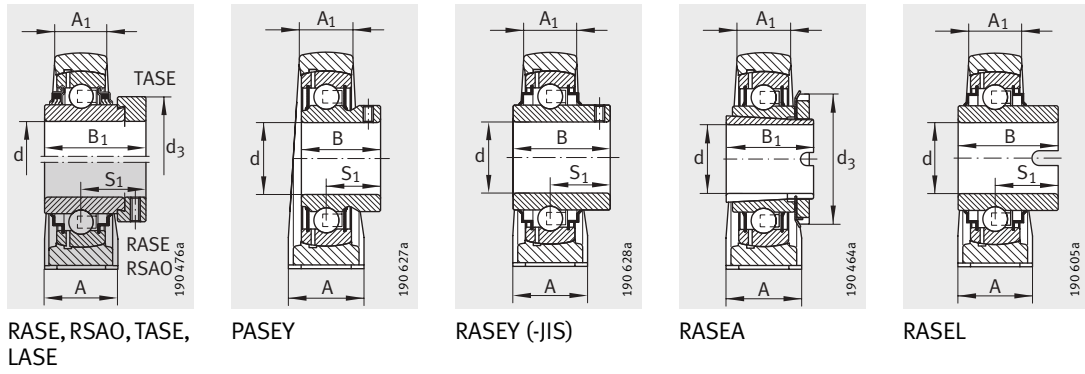

									Basic load ratings		End cap ²⁾
H ₁	H ₂	N	N ₁	B	B ₁	S ₁	Q	d ₃ max.	dyn. C _r N	stat. C _{0r} N	
19	99	14	12	–	43,8	32,7	R _p 1/8	58	32 500	19 800	KASK08
19	99	14	12	–	43,8	32,7	R _p 1/8	58	32 500	19 800	KASK08
19	99	14	12	–	56,5	34,9	R _p 1/8	58	32 500	19 800	KASK08
19	99	14	12	–	56,5	34,9	R _p 1/8	58	32 500	19 800	KASK08
19	99	14	12	–	56,5	34,9	R _p 1/8	58	32 500	19 800	–
19	99	14	12	–	56,5	34,9	R _p 1/8	58	32 500	19 800	KASK08
19	99	14	12	–	56,5	34,9	R _p 1/8	58	32 500	19 800	KASK08
22	116	17,5	10	–	54,6	36,6	R _p 1/8	63	44 500	26 000	–
19	99	14	12	39,5	–	29	R _p 1/8	–	32 500	19 800	KASK08
19	99	14	12	49,2	–	30,2	R _p 1/8	–	32 500	19 800	KASK08
18	98	17	4	49,2	–	30,2	M6	–	32 500	19 800	–
19	99	14	12	–	38	–	R _p 1/8	58	29 500	19 800	KASK08
19	99	14	12	42,9	–	27	R _p 1/8	–	32 500	19 800	KASK08
21,5	107	14	15	–	42,8	32,7	R _p 1/8	63	32 500	20 400	–
21,5	107	14	15	–	43,8	32,7	R _p 1/8	63	32 500	20 400	–
21,5	107	14	15	–	56,5	34,9	R _p 1/8	63	32 500	20 400	–
21,5	107	14	15	–	56,5	34,9	R _p 1/8	63	32 500	20 400	–
21,5	107	14	15	–	56,5	34,9	R _p 1/8	63	32 500	20 400	–
21,5	107	14	15	–	56,5	34,9	R _p 1/8	63	32 500	20 400	–
21,5	107	14	15	41,5	–	30,5	R _p 1/8	–	32 500	20 400	–
21,5	107	14	15	49,2	–	30,2	R _p 1/8	–	32 500	20 400	–
20	106	17	4	49,2	–	30,2	M6	–	32 500	20 400	–
21,5	107	14	15	42,9	–	25,5	R _p 1/8	–	32 500	20 400	–
21,5	115	18	5	–	43,8	32,7	R _p 1/8	69	35 000	23 200	KASK10
21,5	115	18	5	–	43,8	32,7	R _p 1/8	69	35 000	23 200	KASK10
21,5	115	18	5	–	62,8	38,1	R _p 1/8	69	35 000	23 200	KASK10
21,5	115	18	5	–	62,8	38,1	R _p 1/8	69	35 000	23 200	KASK10
21,5	115	18	5	–	62,8	38,1	R _p 1/8	69	35 000	23 200	–
21,5	115	18	5	–	62,8	38,1	R _p 1/8	69	35 000	23 200	KASK10
21,5	115	18	5	–	62,8	38,1	R _p 1/8	69	35 000	23 200	KASK10



Plummer block housing units

Cast iron housings with long base

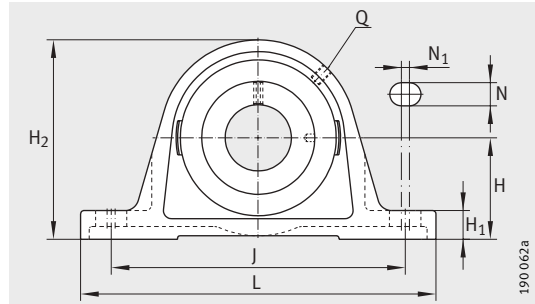

PASE (-FA125), RASE (-FA164), TASE, RSAO, PASEY, RASEY (-JIS), RASEA, RASEL

Dimension table (continued) · Dimensions in mm									
Designation			Mass m ≈ kg	Dimensions					
Unit	Housing	Radial insert ball bearing		d	H	J	L	A	A ₁
RSAO50	GG.SAO10	GNE50-KRR-B	6,1	50	75	212	275	75	39
PASEY50-N	GG.ASE10-N	GAY50-NPP-B	2,32	50	57,2	158	200	54	34
RASEY50-N	GG.ASE10-N	GYE50-KRR-B	2,5	50	57,2	158	200	54	34
RASEY50-JIS	GG.P210	GYE50-KRR-B-FA107	2,57	50	57,2	159	206	60	32
RASEA50-N	GG.ASE10-N	GSH50-2RSR-B	2,09	50	57,2	158	200	54	34
RASEL50-N	GG.ASE10-N	GLE50-KRR-B	2,46	50	57,2	158	200	54	34
PASE55	GG.ASE11	GRAE55-NPP-B	2,79	55	63,5	176	222	60	35
RASE55	GG.ASE11	GE55-KRR-B	3,4	55	63,5	176	222	60	35
TASE55	GG.ASE11	GE55-KTT-B	3,47	55	63,5	176	222	60	35
RASEY55-JIS	GG.P211	GYE55-KRR-B-FA107	3,47	55	63,5	171	219	60	34
RASEY55	GG.ASE11	GYE55-KRR-B	3,08	55	63,5	176	222	60	35
PASE60-N	GG.ASE12-N	GRAE60-NPP-B	4,35	60	69,9	190	240	60	42
PASE60-N-FA125	GG.ASE12-N-FA125.1	GRAE60-NPP-B-FA125.5	4,35	60	69,9	190	240	60	42
RASE60-N	GG.ASE12-N	GE60-KRR-B	4,79	60	69,9	190	240	60	42
RASE60-FA164¹⁾	GG.ASE12-N	GE60-KRR-B-FA164	4,79	60	69,9	190	240	60	42
TASE60-N	GG.ASE12-N	GE60-KTT-B	4,79	60	69,9	190	240	60	42
RSAO60	GG.SAO12	GNE60-KRR-B	9	60	85	250	330	85	46
PASEY60-N	GG.ASE12-N	GAY60-NPP-B	4,02	60	69,9	190	240	60	42
RASEY60-N	GG.ASE12-N	GYE60-KRR-B	4,27	60	69,9	190	240	60	42
RASEY60-JIS	GG.P212	GYE60-KRR-B-FA107	4,53	60	69,8	184	241	70	36
RASEL60-N	GG.ASE12-N	GLE60-KRR-B	4,27	60	69,9	190	240	60	42
RASE65	GG.ASE14	GE65-214-KRR-B	6,41	65	79,4	203	260	65	44
TASE65	GG.ASE14	GE65-214-KTT-B	6,41	65	79,4	203	260	65	44
RASEY65	GG.ASE14	GYE65-214-KRR-B	5,95	65	79,4	203	260	65	44
RASE70	GG.ASE14	GE70-KRR-B	6,15	70	79,4	203	260	65	44
RASE70-FA164¹⁾	GG.ASE14	GE70-KRR-B-FA164	6,15	70	79,4	203	260	65	44
TASE70	GG.ASE14	GE70-KTT-B	6,15	70	79,4	203	260	65	44
RSAO70	GG.ASE14	GNE70-KRR-B	11	70	95	282	360	90	54
RASEY70	GG.ASE14	GYE70-KRR-B	5,65	70	79,4	203	260	65	44
RASEL70	GG.ASE14	GLE70-KRR-B	6,5	70	79,4	203	260	65	44
RASE75	GG.ASE15	GE75-KRR-B	7,65	75	82,5	210	265	66	48
RASE75-FA164¹⁾	GG.ASE15	GE75-KRR-B-FA164	7,65	75	82,5	210	265	66	48
TASE75	GG.ASE15	GE75-KTT-B	7,65	75	82,5	210	265	66	48
RASEY75	GG.ASE15	GYE75-KRR-B	7,19	75	82,5	210	265	66	48

¹⁾ With lubrication nipple DIN 71412-AR 1/8.

²⁾ To be ordered separately.

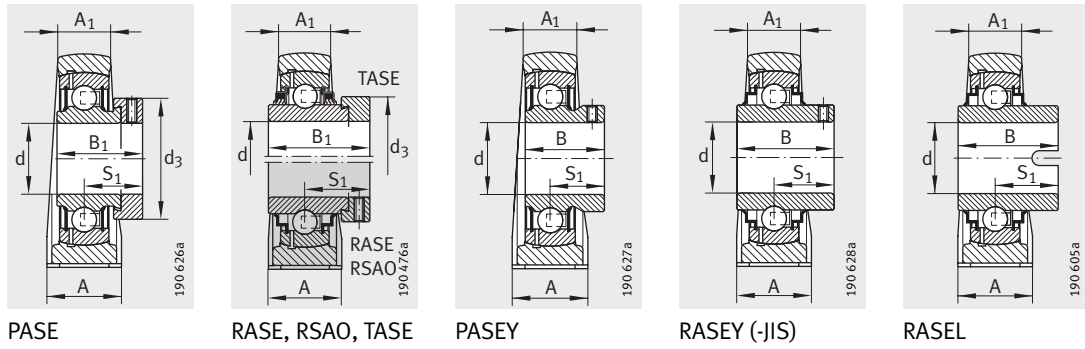

									Basic load ratings		End cap ²⁾
H ₁	H ₂	N	N ₁	B	B ₁	S ₁	Q	d ₃	dyn. C _r	stat. C _{0r}	
								max.	N	N	
27	143	20	15	–	66,8	42,1	R _p 1/8	75,8	62 000	38 000	–
21,5	115	18	5	43	–	32	R _p 1/8	–	35 000	23 200	KASK10
21,5	115	18	5	51,6	–	32,6	R _p 1/8	–	35 000	23 200	KASK10
21	114	20	5	51,6	–	32,6	M6	–	35 000	23 200	–
21,5	115	18	5	–	40	–	R _p 1/8	70	33 000	19 900	KASK10
21,5	115	18	5	49,2	–	30,2	R _p 1/8	–	35 000	23 200	KASK10
22,5	124,5	18	12	–	48,4	36,4	R _p 1/8	76	43 500	29 000	–
22,5	124,5	18	12	–	71,4	43,6	R _p 1/8	76	43 500	29 000	–
22,5	124,5	18	12	–	71,4	43,6	R _p 1/8	76	43 500	29 000	–
23	126	20	5	55,6	–	33,4	M6	–	43 500	29 000	–
22,5	124,5	18	12	55,6	–	33,4	R _p 1/8	–	43 500	29 000	–
25	140	18	10	–	53,1	39,6	R _p 1/8	84	52 000	36 000	KASK12
25	140	18	10	–	53,1	39,6	R _p 1/8	84	52 000	36 000	KASK12
25	140	18	10	–	77,9	46,8	R _p 1/8	84	52 000	36 000	KASK12
25	140	18	10	–	77,9	46,8	R _p 1/8	84	52 000	36 000	–
25	140	18	10	–	77,9	46,8	R _p 1/8	84	52 000	36 000	KASK12
32	165	25	13	–	68,4	45,4	R _p 1/8	89	82 000	52 000	–
25	140	18	10	47	–	34	R _p 1/8	–	52 000	36 000	KASK12
25	140	18	10	65,1	–	39,7	R _p 1/8	–	52 000	36 000	KASK12
25	138	20	5	65,1	–	39,7	M6	–	52 000	36 000	–
25	140	18	10	61,9	–	37,3	R _p 1/8	–	52 000	36 000	KASK12
27,5	156	22	6	–	66	44,6	R _p 1/8	96	62 000	44 000	–
27,5	156	22	6	–	66	44,6	R _p 1/8	96	62 000	44 000	–
27,5	156	22	6	74,6	–	44,4	R _p 1/8	–	62 000	44 000	–
27,5	156	22	6	–	66	44,6	R _p 1/8	96	62 000	44 000	–
27,5	156	22	6	–	66	44,6	R _p 1/8	96	62 000	44 000	–
27,5	156	22	6	–	66	44,6	R _p 1/8	96	62 000	44 000	–
35	187	27	15	–	75,5	49,4	R _p 1/8	102	104 000	68 000	–
27,5	156	22	6	74,6	–	44,4	R _p 1/8	–	62 000	44 000	–
27,5	156	22	6	68,2	–	41,2	R _p 1/8	–	62 000	44 000	–
27,5	164	22	8	–	67	45,6	R _p 1/8	100	62 000	44 500	–
27,5	164	22	8	–	67	45,6	R _p 1/8	100	62 000	44 500	–
27,5	164	22	8	–	67	45,6	R _p 1/8	100	62 000	44 500	–
27,5	164	22	8	77,8	–	44,5	R _p 1/8	–	62 000	44 500	–



Plummer block housing units

Cast iron housings with long base

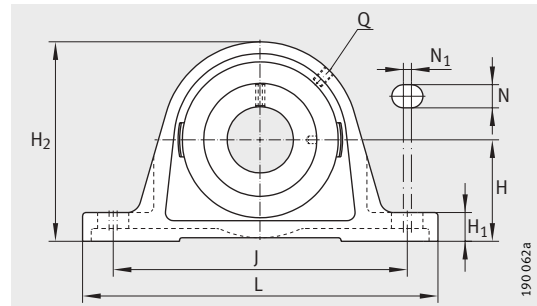

RASE (-FA164), TASE, RSAO, RASEY

Dimension table (continued) - Dimensions in mm							
Designation			Mass m ≈kg	Dimensions			
Unit	Housing	Radial insert ball bearing		d	H	J	L
RASE80	GG.ASE16	GE80-KRR-B	8,65	80	89	232	290
RASE80-AH01-FA164 ¹⁾	GG.ASE16	GE80-KRR-B-AH01-FA164	8,65	80	89	232	290
TASE80	GG.ASE16	GE80-KTT-B	8,65	80	89	232	290
RSAO80	GG.SAO16	GNE80-KRR-B	22,5	80	116	315	390
RASEY80	GG.ASE16	GYE80-KRR-B	8,63	80	89	232	290
RASE90	GG.ASE18	GE90-KRR-B	12,12	90	101,6	268	330
RASE90-FA164 ¹⁾	GG.ASE18	GE90-KRR-B-FA164	12,12	90	101,6	268	330
RSAO90	GG.SAO18	GNE90-KRR-B	29,5	90	130	340	410
RASEY90	GG.ASE18	GYE90-KRR-B	12,6	90	101,6	268	330
RASE100	GG.ASE20	GE100-KRR-B	15,85	100	115	308	380
RSAO100	GG.SAO20	GNE100-KRR-B	41	100	145	375	440
RASE120	GG.ASE24	GE120-KRR-B	25,53	120	135	358	440

¹⁾ With lubrication nipple DIN 71412-AR 1/8.

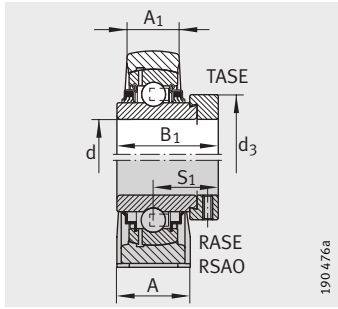

RASE, RSAO, TASE

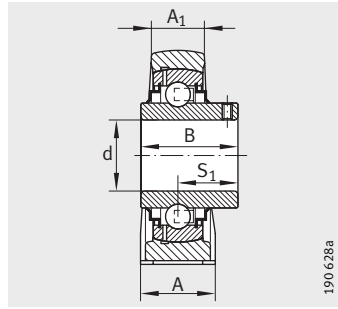

RASEY

											Basic load ratings	
A	A ₁	H ₁	H ₂	N	N ₁	B	B ₁	S ₁	Q	d ₃ max.	dyn. C _r N	stat. C _{0r} N
78	55	30	175	26	8	–	70,7	47,6	R _p 1/8	108	72 000	54 000
78	55	30	175	26	8	–	70,7	47,6	R _p 1/8	108	72 000	54 000
78	55	30	175	26	8	–	71	47,6	R _p 1/8	108	72 000	54 000
110	76	50	226	25,5	19	–	93,6	59,7	R _p 1/8	118	123 000	87 000
78	55	30	175	26	8	82,6	–	49,3	R _p 1/8	–	72 000	54 000
85	55	35	200	27	8	–	69,6	46,6	R _p 1/8	118	96 000	72 000
85	55	35	200	27	8	–	69,6	46,6	R _p 1/8	118	96 000	72 000
120	84	57	250	28	26	–	101	65,5	R _p 1/8	132	143 000	107 000
85	55	35	200	27	8	96	–	56,3	R _p 1/8	–	96 000	72 000
95	62	40	225	30	8	–	75	49,5	R _p 1/8	132	122 000	93 000
130	94	65	280	32	15	–	109,5	70	R _p 1/8	145	174 000	140 000
105	70	45	265	33	8	–	81	52,5	R _p 1/8	152	155 000	131 000



Plummer block housing units

Cast iron housings with short base

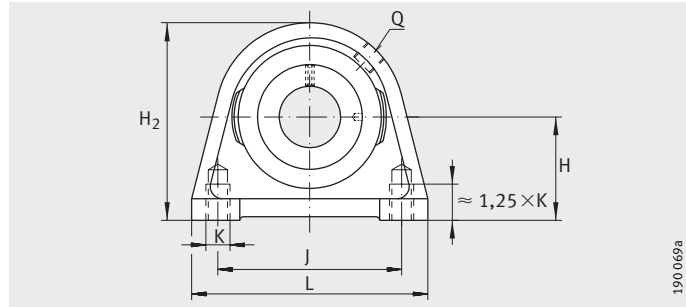

PSHE, RSHE, TSHE, PSHEY, RSHEY

Dimension table · Dimensions in mm							
Designation			Mass m ≈kg	Dimensions			
Unit	Housing	Radial insert ball bearing		d	H	A	A ₁
PSHE12	GG.SHE03	GRAE12-NPP-B	0,44	12	30,2	30	18
PSHEY12	GG.SHE03	GAY12-NPP-B	0,42	12	30,2	30	18
PSHE15	GG.SHE03	GRAE15-NPP-B	0,44	15	30,2	30	18
PSHEY15	GG.SHE03	GAY15-NPP-B	0,41	15	30,2	30	18
RSHEY15	GG.SHE03	GYE15-KRR-B	0,42	15	30,2	30	18
PSHE17	GG.SHE03	GRAE17-NPP-B	0,44	17	30,2	30	18
RSHE17	GG.SHE03	GE17-KRR-B	0,48	17	30,2	30	18
PSHEY17	GG.SHE03	GAY17-NPP-B	0,4	17	30,2	30	18
RSHEY17	GG.SHE03	GYE17-KRR-B	0,41	17	30,2	30	18
PSHE20-N	GG.SHE04-N	GRAE20-NPP-B	0,51	20	33,3	32	19
RSHE20-N	GG.SHE04-N	GE20-KRR-B	0,55	20	33,3	32	19
TSHE20-N	GG.SHE04-N	GE20-KTT-B	0,55	20	33,3	32	19
PSHEY20-N	GG.SHE04-N	GAY20-NPP-B	0,48	20	33,3	32	19
RSHEY20-N	GG.SHE04-N	GYE20-KRR-B	0,52	20	33,3	32	19
PSHE25-N	GG.SHE05-E-N	GRAE25-NPP-B	0,6	25	36,5	36	21
RSHE25-N	GG.SHE05-E-N	GE25-KRR-B	0,66	25	36,5	36	21
TSHE25-N	GG.SHE05-E-N	GE25-KTT-B	0,66	25	36,5	36	21
PSHEY25-N	GG.SHE05-E-N	GAY25-NPP-B	0,57	25	36,5	36	21
RSHEY25-N	GG.SHE05-E-N	GYE25-KRR-B	0,61	25	36,5	36	21
PSHE30-N	GG.SHE06-E-N	GRAE30-NPP-B	1,05	30	42,9	40	25
RSHE30-N	GG.SHE06-E-N	GE30-KRR-B	1,12	30	42,9	40	25
TSHE30-N	GG.SHE06-E-N	GE30-KTT-B	1,13	30	42,9	40	25
PSHEY30-N	GG.SHE06-E-N	GAY30-NPP-B	0,99	30	42,9	40	25
RSHEY30-N	GG.SHE06-E-N	GYE30-KRR-B	1,07	30	42,9	40	25
PSHE35-N	GG.SHE07-E-N	GRAE35-NPP-B	1,44	35	47,6	45	27
RSHE35-N	GG.SHE07-E-N	GE35-KRR-B	1,51	35	47,6	45	27
TSHE35-N	GG.SHE07-E-N	GE35-KTT-B	1,51	35	47,6	45	27
PSHEY35-N	GG.SHE07-E-N	GAY35-NPP-B	1,35	35	47,6	45	27
RSHEY35-N	GG.SHE07-E-N	GYE35-KRR-B	1,45	35	47,6	45	27

¹⁾ To be ordered separately.

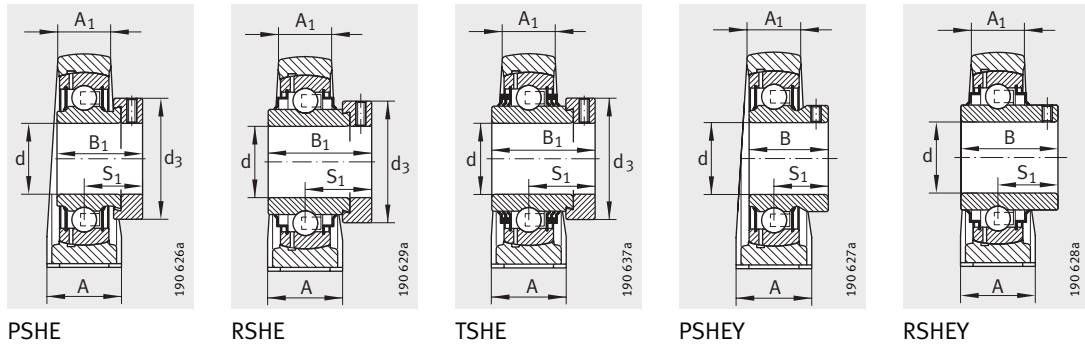

H ₂	K	B	B ₁	J	S ₁	Q	d ₃ max.	L	Basic load ratings		End cap ¹⁾
									dyn. C _r N	stat. C _{0r} N	
57	M8	–	28,6	47	22,1	M6	28	63	9 800	4 750	–
57	M8	22	–	47	16	M6	–	63	9 800	4 750	–
57	M8	–	28,6	47	22,1	M6	28	63	9 800	4 750	–
57	M8	22	–	47	16	M6	–	63	9 800	4 750	–
57	M8	27,4	–	47	15,9	M6	–	63	9 800	4 750	–
57	M8	–	28,6	47	22,1	M6	28	63	9 800	4 750	–
57	M8	–	37,4	47	23,4	M6	28	63	9 800	4 750	–
57	M8	22	–	47	16	M6	–	63	9 800	4 750	–
57	M8	27,4	–	47	15,9	M6	–	63	9 800	4 750	–
64	M8	–	31	50,8	23,5	R _p 1/8	33	65	12 800	6 600	KASK04
64	M8	–	43,7	50,8	26,6	R _p 1/8	33	65	12 800	6 600	KASK04
64	M8	–	43,7	50,8	26,6	R _p 1/8	33	65	12 800	6 600	KASK04
64	M8	25	–	50,8	18	R _p 1/8	–	65	12 800	6 600	KASK04
64	M8	31	–	50,8	18,3	R _p 1/8	–	65	12 800	6 600	KASK04
70	M10	–	31	50,8	23,5	R _p 1/8	37,5	70	14 000	7 800	KASK05
70	M10	–	44,5	50,8	26,9	R _p 1/8	37,5	70	14 000	7 800	KASK05
70	M10	–	44,5	50,8	26,9	R _p 1/8	37,5	70	14 000	7 800	KASK05
70	M10	27	–	50,8	19,5	R _p 1/8	–	70	14 000	7 800	KASK05
70	M10	34,1	–	50,8	19,6	R _p 1/8	–	70	14 000	7 800	KASK05
82	M10	–	35,8	76,2	26,7	R _p 1/8	44	98	19 500	11 300	KASK06
82	M10	–	48,5	76,2	30,1	R _p 1/8	44	98	19 500	11 300	KASK06
82	M10	–	48,5	76,2	30,1	R _p 1/8	44	98	19 500	11 300	KASK06
82	M10	30	–	76,2	21	R _p 1/8	–	98	19 500	11 300	KASK06
82	M10	38,1	–	76,2	22,2	R _p 1/8	–	98	19 500	11 300	KASK06
93	M10	–	39	82,6	29,4	R _p 1/8	51	103	25 500	15 300	KASK07
93	M10	–	51,3	82,6	32,3	R _p 1/8	51	103	25 500	15 300	KASK07
93	M10	–	51,3	82,6	32,3	R _p 1/8	51	103	25 500	15 300	KASK07
93	M10	35	–	82,6	25,5	R _p 1/8	–	103	25 500	15 300	KASK07
93	M10	42,9	–	82,6	25,4	R _p 1/8	–	103	25 500	15 300	KASK07



Plummer block housing units

Cast iron housings with short base

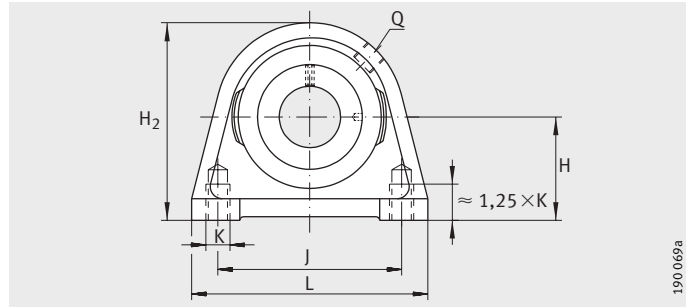

PSHE, RSHE, TSHE, PSHEY, RSHEY

Dimension table (continued) · Dimensions in mm							
Designation			Mass m ≈kg	Dimensions			
Unit	Housing	Radial insert ball bearing		d	H	A	A ₁
PSHE40-N	GG.SHE08-E-N	GRAE40-NPP-B	1,84	40	49,2	48	30
RSHE40-N	GG.SHE08-E-N	GE40-KRR-B	1,96	40	49,2	48	30
TSHE40-N	GG.SHE08-E-N	GE40-KTT-B	1,99	40	49,2	48	30
PSHEY40-N	GG.SHE08-E-N	GAY40-NPP-B	1,73	40	49,2	48	30
RSHEY40-N	GG.SHE08-E-N	GYE40-KRR-B	1,87	40	49,2	48	30
PSHE45	GG.SHE09	GRAE405-NPP-B	2,14	45	54	48	32
RSHE45	GG.SHE09	GE45-KRR-B	2,26	45	54	48	32
TSHE45	GG.SHE09	GE45-KTT-B	2,31	45	54	48	32
PSHEY45	GG.SHE09	GAY405-NPP-B	2	45	54	48	32
RSHEY45	GG.SHE09	GYE45-KRR-B	2,15	45	54	48	32
PSHE50-N	GG.SHE10-E-N	GRAE50-NPP-B	2,79	50	57,2	54	34
RSHE50-N	GG.SHE10-E-N	GE50-KRR-B	3,02	50	57,2	54	34
TSHE50-N	GG.SHE10-E-N	GE50-KTT-B	3,08	50	57,2	54	34
PSHEY50-N	GG.SHE10-E-N	GAY50-NPP-B	2,64	50	57,2	54	34
RSHEY50-N	GG.SHE10-E-N	GYE50-KRR-B	2,82	50	57,2	54	34
PSHE55	GG.SHE11	GRAE505-NPP-B	2,91	55	64	60	35
RSHE55	GG.SHE11	GE55-KRR-B	3,52	55	64	60	35
TSHE55	GG.SHE11	GE55-KTT-B	3,59	55	64	60	35
RSHEY55	GG.SHE11	GYE55-KRR-B	3,2	55	64	60	35
PSHE60-N	GG.SHE12-N	GRAE60-NPP-B	4,1	60	69,9	60	42
RSHE60-N	GG.SHE12-N	GE60-KRR-B	4,54	60	69,9	60	42
TSHE60-N	GG.SHE12-N	GE60-KTT-B	4,54	60	69,9	60	42
PSHEY60-N	GG.SHE12-N	GAY60-NPP-B	3,87	60	69,9	60	42
RSHEY60-N	GG.SHE12-N	GYE60-KRR-B	4,02	60	69,9	60	42

¹⁾ To be ordered separately.

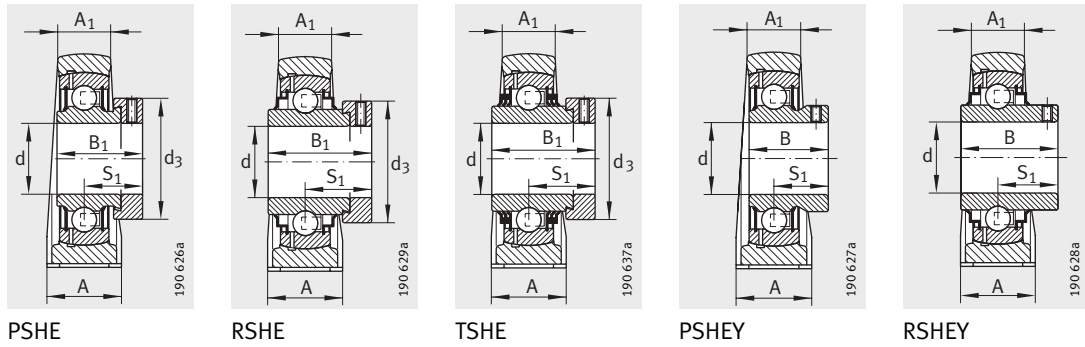

H ₂	K	B	B ₁	J	S ₁	Q	d ₃ max.	L	Basic load ratings		End cap ¹⁾
									dyn. C _r N	stat. C _{0r} N	
99	M12	–	43,8	88,9	32,7	R _p 1/8	58	116	32 500	19 800	KASK08
99	M12	–	56,5	88,9	34,9	R _p 1/8	58	116	32 500	19 800	KASK08
99	M12	–	56,5	88,9	34,9	R _p 1/8	58	116	32 500	19 800	KASK08
99	M12	39,5	–	88,9	29	R _p 1/8	–	116	32 500	19 800	KASK08
99	M12	49,2	–	88,9	30,2	R _p 1/8	–	116	32 500	19 800	KASK08
107	M12	–	43,8	95,3	32,7	R _p 1/8	63	120	32 500	20 400	–
107	M12	–	56,5	95,3	34,9	R _p 1/8	63	120	32 500	20 400	–
107	M12	–	56,5	95,3	34,9	R _p 1/8	63	120	32 500	20 400	–
107	M12	41,5	–	95,3	30,5	R _p 1/8	–	120	32 500	20 400	–
107	M12	49,2	–	95,3	30,5	R _p 1/8	–	120	32 500	20 400	–
115	M16	–	43,8	101,6	32,7	R _p 1/8	69	135	35 000	23 200	KASK10
115	M16	–	62,8	101,6	38,1	R _p 1/8	69	135	35 000	23 200	KASK10
115	M16	–	62,8	101,6	38,1	R _p 1/8	69	135	35 000	23 200	KASK10
115	M16	43	–	101,6	32	R _p 1/8	–	135	35 000	23 200	KASK10
115	M16	51,6	–	101,6	32,6	R _p 1/8	–	135	35 000	23 200	KASK10
125	M16	–	48,4	118	36,4	R _p 1/8	76	150	43 500	29 000	–
125	M16	–	71,4	118	43,6	R _p 1/8	76	150	43 500	29 000	–
125	M16	–	71,4	118	43,6	R _p 1/8	76	150	43 500	29 000	–
125	M16	55,6	–	118	33,4	R _p 1/8	–	150	43 500	29 000	–
140	M16	–	53,1	118	39,6	R _p 1/8	84	150	52 000	36 000	KASK12
140	M16	–	77,9	118	46,8	R _p 1/8	84	150	52 000	36 000	KASK12
140	M16	–	77,9	118	46,8	R _p 1/8	84	150	52 000	36 000	KASK12
140	M16	47	–	118	34	R _p 1/8	–	150	52 000	36 000	KASK12
140	M16	65,1	–	118	39,7	R _p 1/8	–	150	52 000	36 000	KASK12



Two-bolt flanged housing units

Cast iron housings

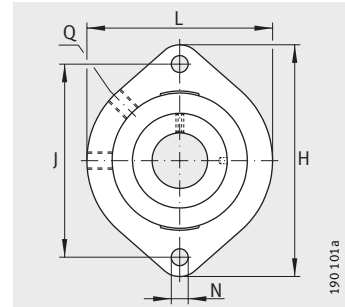

GLCTE

Dimension table · Dimensions in mm							
Designation			Mass m ≈ kg	Dimensions			
Unit	Housing	Radial insert ball bearing		d	L	H	A ₁
FLCTE12	GG.LCTE03	RAE12-NPP-B	0,3	12	58,7	81	15
GLCTE12²⁾	GG.GLCTE03	GRAE12-NPP-B	0,3	12	58,7	81	15
FLCTEY12	GG.LCTE03	AY12-NPP-B	0,28	12	58,7	81	15
FLCTE15	GG.LCTE03	RAE15-NPP-B	0,3	15	58,7	81	15
GLCTE15²⁾	GG.GLCTE03	GRAE15-NPP-B	0,3	15	58,7	81	15
FLCTEY15	GG.LCTE03	AY15-NPP-B	0,27	15	58,7	81	15
FLCTE17	GG.LCTE03	RAE17-NPP-B	0,3	17	58,7	81	15
GLCTE17²⁾	GG.GLCTE03	GRAE17-NPP-B	0,3	17	58,7	81	15
FLCTEY17	GG.LCTE03	AY17-NPP-B	0,26	17	58,7	81	15
FLCTE20	GG.LCTE04	RAE20-NPP-B	0,39	20	66,5	90,5	17
GLCTE20¹⁾	GG.GLCTE04-E	GRAE20-NPP-B	0,39	20	66,5	90,5	17
FLCTEY20	GG.LCTE04	AY20-NPP-B	0,36	20	66,5	90,5	17
FLCTE25	GG.LCTE05	RAE25-NPP-B	0,47	25	71	97	17,5
GLCTE25¹⁾	GG.GLCTE05-E	GRAE25-NPP-B	0,47	25	71	97	17,5
FLCTEY25	GG.LCTE05	AY25-NPP-B	0,44	25	71	97	17,5
FLCTE30	GG.LCTE06	RAE30-NPP-B	0,76	30	84	112,5	20,5
GLCTE30¹⁾	GG.GLCTE06-E	GRAE30-NPP-B	0,76	30	84	112,5	20,5
FLCTEY30	GG.LCTE06	AY30-NPP-B	0,7	30	84	112,5	20,5
FLCTE35	GG.LCTE07	RAE35-NPP-B	1,02	35	94	126	22
GLCTE35²⁾	GG.GLCTE07	GRAE35-NPP-B	1,02	35	94	126	22
FLCTEY35	GG.LCTE07	GAY35-NPP-B	0,93	35	94	126	22
FLCTE40	GG.LCTE08	RAE40-NPP-B	1,27	40	100	150	24
GLCTE40²⁾	GG.GLCTE08	GRAE40-NPP-B	1,27	40	100	150	24
FLCTEY40	GG.LCTE08	GAY40-NPP-B	1,18	40	100	150	24

¹⁾ Lubrication hole 45°.

²⁾ Lubrication hole 90°.

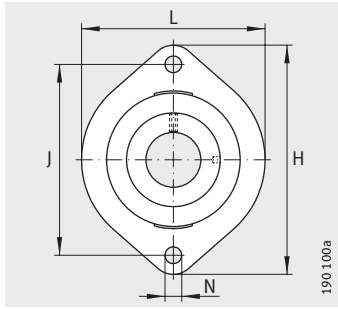

FLCTE, FLCTEY

190 100a

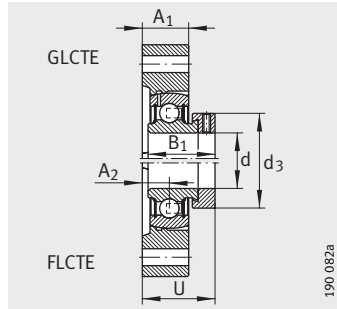

GLCTE, FLCTE

190 082a

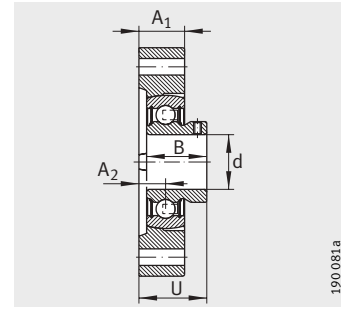

FLCTEY

190 081a

								Basic load ratings	
N	B	B ₁	J	A ₂	Q	d ₃	U	dyn. C _r N	stat. C _{0r} N
6,6	–	28,6	63,5	8,4	–	28	30,5	9 800	4 750
6,6	–	28,6	63,5	8,4	M6 ²⁾	28	30,5	9 800	4 750
6,6	22	–	63,5	8,4	–	–	24,4	9 800	4 750
6,6	–	28,6	63,5	8,4	–	28	30,5	9 800	4 750
6,6	–	28,6	63,5	8,4	M6 ²⁾	28	30,5	9 800	4 750
6,6	22	–	63,5	8,4	–	–	24,4	9 800	4 750
6,6	–	28,6	63,5	8,4	–	28	30,5	9 800	4 750
6,6	–	28,6	63,5	8,4	M6 ²⁾	28	30,5	9 800	4 750
6,6	22	–	63,5	8,4	–	–	24,4	9 800	4 750
9	–	31	71,4	9,5	–	33	33	12 800	6 600
9	–	31	71,4	9,5	M6 ¹⁾	33	33	12 800	6 600
9	25	–	71,4	9,5	–	–	27	12 800	6 600
9	–	31	76,2	9,9	–	37,5	33,4	14 000	7 800
9	–	31	76,2	9,9	M6 ¹⁾	37,5	33,4	14 000	7 800
9	27	–	76,2	9,9	–	–	29,4	14 000	7 800
11,5	–	35,8	90,5	11,4	–	44	38,1	19 500	11 300
11,5	–	35,8	90,5	11,4	R _p 1/8 ¹⁾	44	38,1	19 500	11 300
11,5	30	–	90,5	11,4	–	–	32,4	19 500	11 300
11,5	–	39	100	12,4	–	51	41,8	25 500	15 300
11,5	–	39	100	12,4	R _p 1/8 ²⁾	51	41,8	25 500	15 300
11,5	35	–	100	12,4	–	–	37,9	25 500	15 300
14	–	43,8	119	13,5	–	58	46,2	32 500	19 800
14	–	43,8	119	13,5	R _p 1/8 ²⁾	58	46,2	32 500	19 800
14	39,5	–	119	13,5	–	–	42,5	32 500	19 800



Two-bolt flanged housing units

Cast iron housings

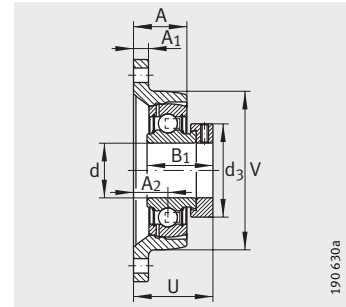
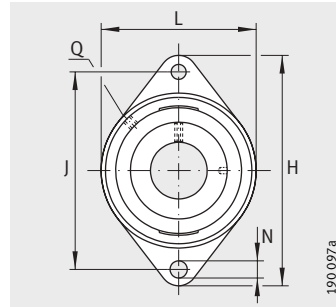

PCFT, PCJT (-N-FA125), PCJTY,
RCJT (-N-FA125), TCJT, LCJT,
RCJTA, RCJTY (-JIS)

PCFT, PCJT

Dimension table · Dimensions in mm								
Designation			Mass m ≈kg	Dimensions				
Unit	Housing	Radial insert ball bearing		d	L	H	A ₁	N
PCFT12	GG.CFT03	GRAE12-NPP-B	0,39	12	57	99	9,5	11,5
PCJT12	GG.CJT03	GRAE12-NPP-B	0,37	12	57	99	9,5	11,5
PCJTY12	GG.CJT03	GAY12-NPP-B	0,35	12	57	99	9,5	11,5
RCJTY12	GG.CJT03	GYE12-KRR-B	0,36	12	57	99	9,5	11,5
PCFT15	GG.CFT03	GRAE15-NPP-B	0,39	15	57	99	9,5	11,5
PCJT15	GG.CFT03	GRAE15-NPP-B	0,37	15	57	99	9,5	11,5
PCJTY15	GG.CFT03	GAY15-NPP-B	0,34	15	57	99	9,5	11,5
RCJTY15	GG.CFT03	GYE15-KRR-B	0,35	15	57	99	9,5	11,5
RCJTY16	GG.CJT03	GYE16-KRR-B	0,34	16	57	99	9,5	11,5
PCFT17	GG.CFT03	GRAE17-NPP-B	0,39	17	57	99	9,5	11,5
PCJT17	GG.CJT03	GRAE17-NPP-B	0,37	17	57	99	9,5	11,5
RCJT17	GG.CJT03	GE17-KRR-B	0,41	17	57	99	9,5	11,5
PCJTY17	GG.CJT03	GAY17-NPP-B	0,33	17	57	99	9,5	11,5
RCJTY17	GG.CJT03	GYE17-KRR-B	0,34	17	57	99	9,5	11,5
PCFT20	GG.CFT04	GRAE20-NPP-B	0,40	20	61	112	10	11,5
PCJT20-N	GG.CJT04-N	GRAE20-NPP-B	0,48	20	61	112	10	11,5
PCJT20-N-FA125	GG.CJT04-N-FA125.1	GRAE20-NPP-B-FA125.5	0,48	20	61	112	10	11,5
RCJT20-N	GG.CJT04-N	GE20-KRR-B	0,52	20	61	112	10	11,5
RCJT20-N-FA125	GG.CJT04-N-FA125.1	GE20-KRR-B-FA125.5	0,52	20	61	112	10	11,5
TCJT20-N	GG.CJT04-N	GE20-KTT-B	0,52	20	61	112	10	11,5
LCJT20-N	GG.CJT04-N	GE20-KLL-B	0,52	20	61	112	10	11,5
RCJTA20-N	GG.CJT04-N	GSH20-2RSR-B	0,52	20	61	112	10	11,5
PCJTY20-N	GG.CJT04-N	GAY20-NPP-B	0,45	20	61	112	10	11,5
RCJTY20-N	GG.CJT04-N	GYE20-KRR-B	0,49	20	61	112	10	11,5
RCJTY20-JIS	GG.FL204	GYE20-KRR-B-FA107	0,42	20	60	113	12	12
PCFT25	GG.CFT05	GRAE25-NPP-B	0,52	25	70	124	11	11,5
PCJT25-N	GG.CJT05-N	GRAE25-NPP-B	0,56	25	70	124	11	11,5
PCJT25-N-FA125	GG.CJT05-N-FA125.1	GRAE25-NPP-B-FA125.5	0,56	25	70	124	11	11,5
RCJT25-N	GG.CJT05-N	GE25-KRR-B	0,62	25	70	124	11	11,5
RCJT25-N-FA125	GG.CJT05-N-FA125.1	GE25-KRR-B-FA125.5	0,62	25	70	124	11	11,5
TCJT25-N	GG.CJT05-N	GE25-KTT-B	0,62	25	70	124	11	11,5
LCJT25-N	GG.CJT05-N	GE25-KLL-B	0,62	25	70	124	11	11,5
RCJTA25-N	GG.CJT05-N	GSH25-2RSR-B	0,54	25	70	124	11	11,5
PCJTY25-N	GG.CJT05-N	GAY25-NPP-B	0,48	25	70	124	11	11,5
RCJTY25-N	GG.CJT05-N	GYE25-KRR-B	0,57	25	70	124	11	11,5
RCJTY25-JIS	GG.FL205	GYE25-KRR-B-FA107	0,61	25	68	130	14	16

¹⁾ To be ordered separately.

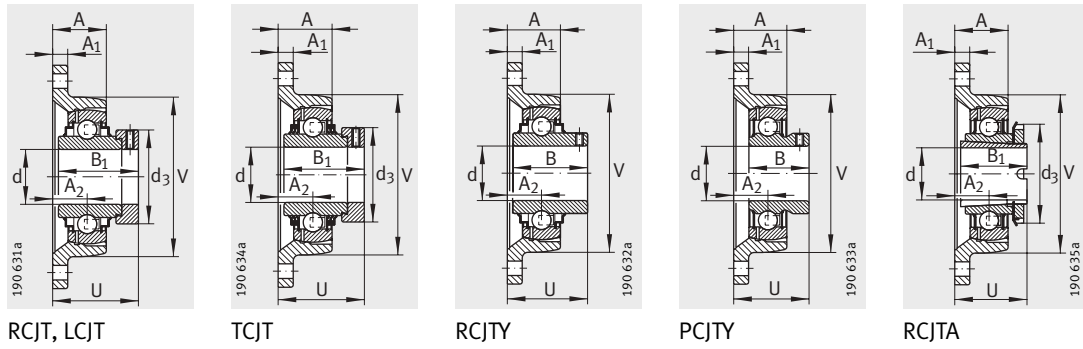

									Basic load ratings		End cap ¹⁾
B	B ₁	J	A ₂	Q	d ₃ max.	A	U	V	dyn. C _r N	stat. C _{0r} N	
-	28,6	76,5	10	M6	28	18	32,1	57	9 800	4 750	-
-	28,6	76,5	17	M6	28	25	39,1	57	9 800	4 750	-
22	-	76,5	17	M6	-	25	33	57	9 800	4 750	-
27,4	-	76,5	17	M6	-	25	32,9	57	9 800	4 750	-
-	28,6	76,5	10	M6	28	18	32,1	57	9 800	4 750	-
-	28,6	76,5	17	M6	28	25	39,1	57	9 800	4 750	-
22	-	76,5	17	M6	-	25	33	57	9 800	4 750	-
27,4	-	76,5	17	M6	-	25	32,9	57	9 800	4 750	-
27,4	-	76,5	17	M6	-	25	32,9	57	9 800	4 750	-
-	28,6	76,5	10	M6	28	18	32,1	57	9 800	4 750	-
-	28,6	76,5	17	M6	28	25	39,1	57	9 800	4 750	-
-	37,4	76,5	17	M6	28	25	40,4	57	9 800	4 750	-
22	-	76,5	17	M6	-	25	33	57	9 800	4 750	-
27,4	-	76,5	17	M6	-	25	32,9	57	9 800	4 750	-
-	31	90	10,5	R _p 1/8	33	17,5	34	61	12 800	6 600	-
-	31	90	19	R _p 1/8	33	28	42,5	61	12 800	6 600	KASK04
-	31	90	19	R _p 1/8	33	28	42,5	61	12 800	6 600	KASK04
-	43,7	90	19	R _p 1/8	33	28	45,6	61	12 800	6 600	KASK04
-	43,7	90	19	R _p 1/8	33	28	45,6	61	12 800	6 600	KASK04
-	43,7	90	19	R _p 1/8	33	28	45,6	61	12 800	6 600	KASK04
-	43,7	90	19	R _p 1/8	33	28	45,6	61	12 800	6 600	KASK04
-	28	90	19	R _p 1/8	32	28	42,5	61	12 700	6 600	KASK04
25	-	90	19	R _p 1/8	-	28	37	61	12 800	6 600	KASK04
31	-	90	19	R _p 1/8	-	28	37,3	61	12 800	6 600	KASK04
31	-	90	15	M6	-	25,5	33,3	-	12 800	6 600	-
-	31	99	12,5	R _p 1/8	37,5	20	36	70	14 000	7 800	-
-	31	99	19	R _p 1/8	37,5	29	42,5	70	14 000	7 800	KASK05
-	31	99	19	R _p 1/8	37,5	29	42,5	70	14 000	7 800	KASK05
-	44,5	99	19	R _p 1/8	37,5	29	46	70	14 000	7 800	KASK05
-	44,5	99	19	R _p 1/8	37,5	29	46	70	14 000	7 800	KASK05
-	44,5	99	19	R _p 1/8	37,5	29	46	70	14 000	7 800	KASK05
-	44,5	99	19	R _p 1/8	37,5	29	46	70	14 000	7 800	KASK05
-	28	99	19	R _p 1/8	38	29	42,5	70	13 600	7 800	KASK05
27	-	99	19	R _p 1/8	-	29	38,5	70	14 000	7 800	KASK05
34,1	-	99	19	R _p 1/8	-	29	38,8	70	14 000	7 800	KASK05
34,1	-	99	16	M6	-	27	35,8	-	14 000	7 800	-



Two-bolt flanged housing units

Cast iron housings

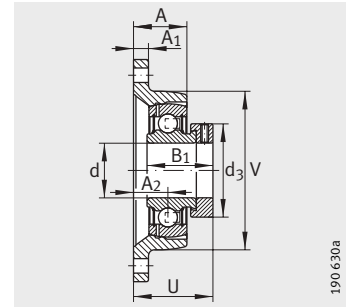
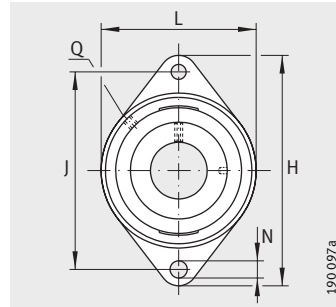

PCFT, PCJT (-N-FA125), PCJTY,
RCJT (-N-FA125, -FA164), TCJT,
LCJT, RCJTA, RCJTY (-JIS)

PCFT, PCJT

Dimension table (continued) · Dimensions in mm								
Designation			Mass m ≈kg	Dimensions				
Unit	Housing	Radial insert ball bearing		d	L	H	A ₁	N
PCFT30	GG.CFT06	GRAE30-NPP-B	0,77	30	80	142	12	11,5
PCJT30-N	GG.CJT06-N	GRAE30-NPP-B	0,81	30	80	142	12	11,5
PCJT30-N-FA125	GG.CJT06-N-FA125.1	GRAE30-NPP-B-FA125.5	0,81	30	80	142	12	11,5
RCJT30-N	GG.CJT06-N	GE30-KRR-B	0,88	30	80	142	12	11,5
RCJT30-N-FA125	GG.CJT06-N-FA125.1	GE30-KRR-B-FA125.5	0,88	30	80	142	12	11,5
RCJT30-FA164¹⁾	GG.CJT06-N	GE30-KRR-B-FA164	0,88	30	80	142	12	11,5
TCJT30-N	GG.CJT06-N	GE30-KTT-B	0,89	30	80	142	12	11,5
LCJT30-N	GG.CJT06-N	GE30-KLL-B	0,88	30	80	142	12	11,5
RCJTA30-N	GG.CJT06-N	GSH30-2RSR-B	0,77	30	80	142	12	11,5
PCJTY30-N	GG.CJT06-N	GAY30-NPP-B	0,75	30	80	142	12	11,5
RCJTY30-N	GG.CJT06-N	GYE30-KRR-B	0,88	30	80	142	12	11,5
RCJTY30-JIS	GG.FL206	GYE30-KRR-B-FA107	0,91	30	80	148	14	16
PCFT35	GG.CFT07	GRAE35-NPP-B	1,08	35	92	155	12,5	14
PCJT35-N	GG.CJT07-N	GRAE35-NPP-B	1,12	35	92	155	12,5	14
PCJT35-N-FA125	GG.CJT07-N-FA125.1	GRAE35-NPP-B-FA125.5	1,12	35	92	155	12,5	14
RCJT35-N	GG.CJT07-N	GE35-KRR-B	1,19	35	92	155	12,5	14
RCJT35-N-FA125	GG.CJT07-N-FA125.1	GE35-KRR-B-FA125.5	1,19	35	92	155	12,5	14
RCJT35-FA164¹⁾	GG.CJT07-N	GE35-KRR-B-FA164	1,19	35	92	155	12,5	14
TCJT35-N	GG.CJT07-N	GE35-KTT-B	1,2	35	92	155	12,5	14
LCJT35-N	GG.CJT07-N	GE35-KLL-B	1,19	35	92	155	12,5	14
RCJTA35-N	GG.CJT07-N	GSH35-2RSR-B	1,06	35	92	155	12,5	14
PCJTY35-N	GG.CJT07-N	GAY35-NPP-B	1,03	35	92	155	12,5	14
RCJTY35-N	GG.CJT07-N	GYE35-KRR-B	1,13	35	92	155	12,5	14
RCJTY35-JIS	GG.FL207	GYE35-KRR-B-FA107	1,19	35	90	161	16	16
PCFT40	GG.CFT08	GRAE40-NPP-B	1,42	40	105	172	13	14
PCJT40-N	GG.CJT08-N	GRAE40-NPP-B	1,54	40	105	172	13	14
PCJT40-N-FA125	GG.CJT08-N-FA125.1	GRAE40-NPP-B-FA125.5	1,54	40	105	172	13	14
RCJT40-N	GG.CJT08-N	GE40-KRR-B	1,66	40	105	172	13	14
RCJT40-N-FA125	GG.CJT08-N-FA125.1	GE40-KRR-B-FA125.5	1,66	40	105	172	13	14
RCJT40-FA164¹⁾	GG.CJT08-N	GE40-KRR-B-FA164	1,66	40	105	172	13	14

¹⁾ With lubrication nipple DIN 71412-AR 1/8.

²⁾ To be ordered separately.

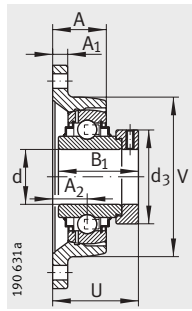

RCJT, LCJT

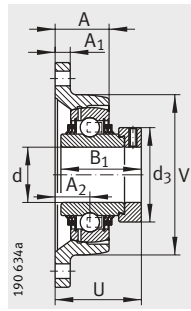

TCJT

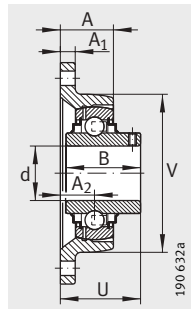

RCJTY (-JIS)

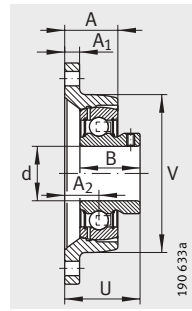

PCJTY

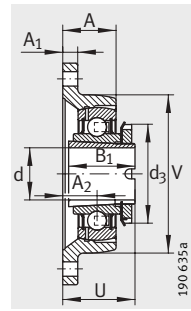

RCJTA

									Basic load ratings		End cap ²⁾
B	B ₁	J	A ₂	Q	d ₃ max.	A	U	V	dyn. C _r N	stat. C _{0r} N	
-	35,8	116,5	13,3	R _p 1/8	44	22,3	40	80	19 500	11 300	-
-	35,8	116,5	20	R _p 1/8	44	29	46,7	80	19 500	11 300	KASK06
-	35,8	116,5	20	R _p 1/8	44	29	46,7	80	19 500	11 300	KASK06
-	48,5	116,5	20	R _p 1/8	44	29	50,1	80	19 500	11 300	KASK06
-	48,5	116,5	20	R _p 1/8	44	29	50,1	80	19 500	11 300	KASK06
-	48,5	116,5	20	R _p 1/8	44	29	50,2	80	19 500	11 300	-
-	48,5	116,5	20	R _p 1/8	44	29	50,1	80	19 500	11 300	KASK06
-	48,5	116,5	20	R _p 1/8	44	29	50,1	80	19 500	11 300	KASK06
-	32	116,5	20	R _p 1/8	45	29	44	80	18 900	11 300	KASK06
30	-	116,5	20	R _p 1/8	-	29	41	80	19 500	11 300	KASK06
38,1	-	116,5	20	R _p 1/8	-	29	42,2	80	19 500	11 300	KASK06
38,1	-	117	18	M6	-	31	40,2	-	19 500	11 300	-
-	39	130	15,5	R _p 1/8	51	25	44,9	92	25 500	15 300	-
-	39	130	21	R _p 1/8	51	30,5	50,4	92	25 500	15 300	KASK07
-	39	130	21	R _p 1/8	51	30,5	50,4	92	25 500	15 300	KASK07
-	51,3	130	21	R _p 1/8	51	30,5	53,3	92	25 500	15 300	KASK07
-	51,3	130	21	R _p 1/8	51	30,5	53,3	92	25 500	15 300	KASK07
-	51,3	130	21	R _p 1/8	51	30,5	53,4	92	25 500	15 300	-
-	51,3	130	21	R _p 1/8	51	30,5	53,3	92	25 500	15 300	KASK07
-	51,3	130	21	R _p 1/8	51	30,5	53,3	92	25 500	15 300	KASK07
-	34	130	21	R _p 1/8	52	30,5	46	92	24 900	15 300	KASK07
35	-	130	21	R _p 1/8	-	30,5	46,5	92	25 500	15 300	KASK07
42,9	-	130	21	R _p 1/8	-	30,5	46,4	92	25 500	15 300	KASK07
42,9	-	130	19	M6	-	34	44,4	-	25 500	15 300	-
-	43,8	143,5	18,3	R _p 1/8	58	28,8	51	105	32 500	19 800	-
-	43,8	143,5	24	R _p 1/8	58	34,5	56,7	105	32 500	19 800	KASK08
-	43,8	143,5	24	R _p 1/8	58	34,5	56,7	105	32 500	19 800	KASK08
-	56,5	143,5	24	R _p 1/8	58	34,5	58,9	105	32 500	19 800	KASK08
-	56,5	143,5	24	R _p 1/8	58	34,5	58,9	105	32 500	19 800	KASK08
-	56,5	143,5	24	R _p 1/8	58	34,5	59,1	105	32 500	19 800	-



Two-bolt flanged housing units

Cast iron housings

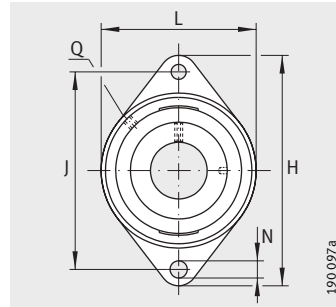

PCFT, PCJT (-N-FA125), PCJTY, RCJT (-N-FA125, -FA164), TCJT, LCJT, RCJTA, RCJTY (-JIS)

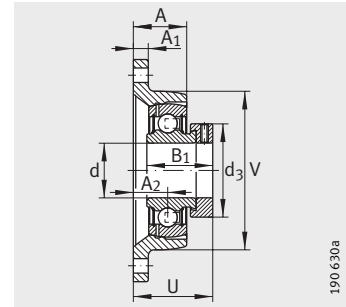

PCFT, PCJT

Dimension table (continued) · Dimensions in mm								
Designation			Mass m ≈kg	Dimensions				
Unit	Housing	Radial insert ball bearing		d	L	H	A ₁	N
TCJT40-N	GG.CJT08-N	GE40-KTT-B	1,69	40	105	172	13	14
LCJT40-N	GG.CJT08-N	GE40-KLL-B	1,66	40	105	172	13	14
PCJTY40-N	GG.CJT08-N	GAY40-NPP-B	1,43	40	105	172	13	14
RCJTA40-N	GG.CJT08-N	GSH40-2RSR-B	1,46	40	105	172	13	14
RCJTY40-N	GG.CJT08-N	GYE40-KRR-B	1,57	40	105	172	13	14
RCJTY40-JIS	GG.FL208	GYE40-KRR-B-FA107	1,51	40	100	175	16	16
PCFT45	GG.CFT09	GRAE45-NPP-B	1,59	45	111	180	13	14
PCJT45	GG.CJT09	GRAE45-NPP-B	1,69	45	111	180	13	14
RCJT45	GG.CJT09	GE45-KRR-B	1,81	45	111	180	13	14
TCJT45	GG.CJT09	GE45-KTT-B	1,81	45	111	180	13	14
LCJT45	GG.CJT09	GE45-KLL-B	1,81	45	111	180	13	14
PCJTY45	GG.CJT09	GAY45-NPP-B	1,55	45	111	180	13	14
RCJTY45	GG.CJT09	GYE45-KRR-B	1,7	45	111	180	13	14
RCJTY45-JIS	GG.FL209	GYE45-KRR-B-FA107	1,94	45	108	188	18	19
PCFT50	GG.CFT10	GRAE50-NPP-B	1,82	50	116	190	13	14
PCJT50-N	GG.CJT10-N	GRAE50-NPP-B	1,97	50	116	190	13	18
PCJT50-N-FA125	GG.CJT10-N-FA125.1	GRAE50-NPP-B-FA125.5	1,97	50	116	190	13	18
RCJT50-N	GG.CJT10-N	GE50-KRR-B	2,2	50	116	190	13	18
RCJT50-N-FA125	GG.CJT10-N-FA125.1	GE50-KRR-B-FA125.5	2,2	50	116	190	13	18
RCJT50-FA164¹⁾	GG.CJT10-N	GE50-KRR-B-FA164	2,2	50	116	190	13	18
TCJT50-N	GG.CJT10-N	GE50-KTT-B	2,26	50	116	190	13	18
LCJT50-N	GG.CJT10-N	GE50-KLL-B	2,2	50	116	190	13	18
PCJTY50-N	GG.CJT10-N	GAY50-NPP-B	1,82	50	116	190	13	18
RCJTY50-N	GG.CJT10-N	GYE50-KRR-B	2	50	116	190	13	18
RCJTY50-JIS	GG.FL210	GYE50-KRR-B-FA107	2,21	50	115	197	18	19
PCJT55	GG.CJT11	GRAE55-NPP-B	2,31	55	134	222	15	18
RCJT55	GG.CJT11	GE55-KRR-B	2,92	55	134	222	15	18
TCJT55	GG.CJT11	GE55-KTT-B	2,98	55	134	222	15	18
RCJTY55	GG.CJT11	GYE55-KRR-B	2,6	55	134	222	15	18
RCJTY55-JIS	GG.FL211	GYE55-KRR-B-FA107	2,83	55	130	224	20	19

¹⁾ With lubrication nipple DIN 71412-AR 1/8.

²⁾ To be ordered separately.

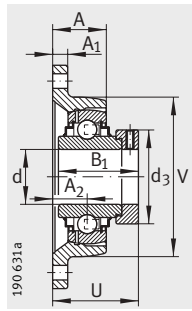

RCJT, LCJT

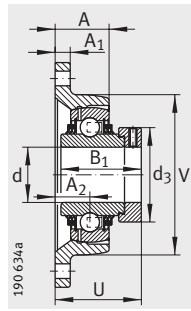

TCJT

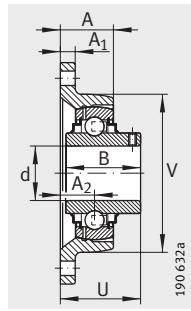

RCJTY (-JIS)

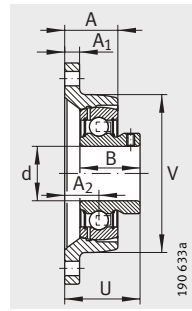

PCJTY

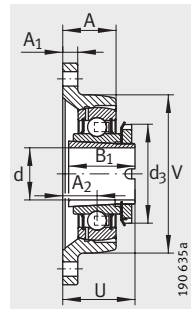

RCJTA

									Basic load ratings		End cap ²⁾
B	B ₁	J	A ₂	Q	d ₃ max.	A	U	V	dyn. C _r N	stat. C _{0r} N	
-	56,5	143,5	24	R _p 1/8	58	34,5	58,9	105	32 500	19 800	KASK08
-	56,5	143,5	24	R _p 1/8	58	34,5	58,9	105	32 500	19 800	KASK08
39,5	-	143,5	24	R _p 1/8	-	34,5	53	105	32 500	19 800	KASK08
-	38	143,5	24	R _p 1/8	58	34,5	51	105	29 500	19 800	KASK08
49,2	-	143,5	24	R _p 1/8	-	34,5	54,2	105	32 500	19 800	KASK08
49,2	-	144	21	M6	-	36	51,2	-	32 500	19 800	-
-	43,8	148,5	19,2	R _p 1/8	63	30,2	51,9	111	32 500	20 400	-
-	43,8	148,5	24	R _p 1/8	63	35	56,7	111	32 500	20 400	-
-	56,5	148,5	24	R _p 1/8	63	35	58,9	111	32 500	20 400	-
-	56,5	148,5	24	R _p 1/8	63	35	58,9	111	32 500	20 400	-
-	56,5	148,5	24	R _p 1/8	63	35	58,9	111	32 500	20 400	-
41,5	-	148,5	24	R _p 1/8	-	35	54,5	111	32 500	20 400	-
49,2	-	148,5	24	R _p 1/8	-	35	54,2	111	32 500	20 400	-
49,2	-	148	22	M6	-	38	52,2	-	32 500	20 400	-
-	43,8	157	19,2	R _p 1/8	69	30,2	51,9	116	35 000	23 200	-
-	43,8	157	28	R _p 1/8	69	39	60,7	116	35 000	23 200	KASK10
-	43,8	157	28	R _p 1/8	69	39	60,7	116	35 000	23 200	KASK10
-	62,8	157	28	R _p 1/8	69	39	66,1	116	35 000	23 200	KASK10
-	62,8	157	28	R _p 1/8	69	39	66,1	116	35 000	23 200	KASK10
-	62,8	157	28	R _p 1/8	69	39	66,1	116	35 000	23 200	-
-	62,8	157	28	R _p 1/8	69	39	66,1	116	35 000	23 200	KASK10
-	62,8	157	28	R _p 1/8	69	39	66,1	116	35 000	23 200	KASK10
43	-	157	28	R _p 1/8	-	39	60	116	35 000	23 200	KASK10
51,6	-	157	28	R _p 1/8	-	39	60,6	116	35 000	23 200	KASK10
51,6	-	157	22	M6	-	40	54,6	-	35 000	23 200	-
-	48,4	184	31	R _p 1/8	76	43,5	67,4	134	43 500	29 000	-
-	71,4	184	31	R _p 1/8	76	43,5	74,6	134	43 500	29 000	-
-	71,4	184	31	R _p 1/8	76	43,5	74,6	134	43 500	29 000	-
55,6	-	184	31	R _p 1/8	-	43,5	64,4	134	43 500	29 000	-
55,6	-	184	25	M6	-	43	58,4	-	43 500	29 000	-



Two-bolt flanged housing units

Cast iron housings

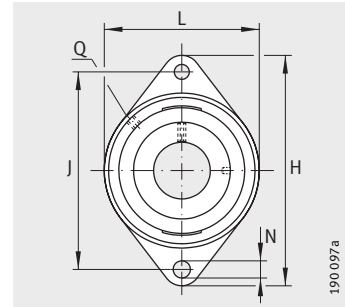

PCJT (-N-FA125), PCJTY, RCJT, TCJT, RCJTY (-JIS)

Dimension table (continued) · Dimensions in mm								
Designation			Mass m ≈kg	Dimensions				
Unit	Housing	Radial insert ball bearing		d	L	H	A ₁	N
PCJT60-N	GG.CJT12-N	GRAE60-NPP-B	3,25	60	138	238	16	18
PCJT60-N-FA125	GG.CJT12-N-FA125.1	GRAE60-NPP-B-FA125.5	3,25	60	138	238	16	18
RCJT60-N	GG.CJT12-N	GE60-KRR-B	3,69	60	138	238	16	18
PCJTY60-N	GG.CJT12-N	GAY60-NPP-B	2,92	60	138	238	16	18
RCJTY60-N	GG.CJT12-N	GYE60-KRR-B	3,17	60	138	238	16	18
RCJTY60-JIS	GG.FL212	GYE60-KRR-B-FA107	3,88	60	140	250	20	23
RCJT65	GG.CJT13/14	GE65-214-KRR-B	6,41	65	160	258	18	21
TCJT65	GG.CJT13/14	GE65-214-KTT-B	6,41	65	160	258	18	21
RCJTY65	GG.CJT13/14	GYE65-214-KRR-B	5,95	65	160	258	18	21
RCJT70	GG.CJT13/14	GE70-KRR-B	6,15	70	160	258	18	21
RCJTY70	GG.CJT13/14	GYE70-KRR-B	5,65	70	160	258	18	21
RCJT75	GG.CJT15	GE75-KRR-B	6	75	160	258	18	21
TCJT75	GG.CJT15	GE75-KTT-B	6	75	160	258	18	21
RCJTY75	GG.CJT15	GYE75-KRR-B	5,54	75	160	258	18	21

1) To be ordered separately.

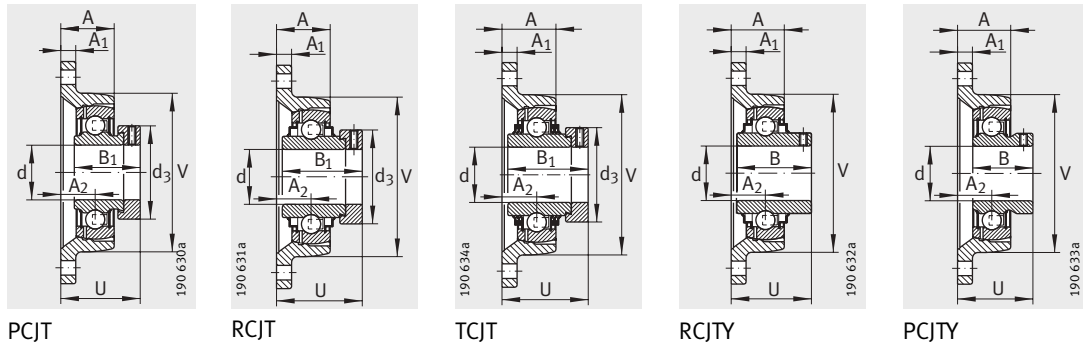

B	B ₁	J	A ₂	Q	d ₃ max.	A	U	V	Basic load ratings		End cap ¹⁾
									dyn. C _r N	stat. C _{0r} N	
-	53,1	202	34	R _p 1/8	84	46	73,6	138	52 000	36 000	KASK12
-	53,1	202	34	R _p 1/8	84	46	73,6	138	52 000	36 000	KASK12
-	77,9	202	34	R _p 1/8	84	46	80,8	138	52 000	36 000	KASK12
47	-	202	34	R _p 1/8	-	46	68	138	52 000	36 000	KASK12
65,1	-	202	34	R _p 1/8	-	46	73,7	138	52 000	36 000	KASK12
65,1	-	202	29	M6	-	48	68,7	-	52 000	36 000	-
-	66	216	38	R _p 1/8	96	57	82,6	160	62 000	44 000	-
-	66	216	38	R _p 1/8	96	57	82,6	160	62 000	44 000	-
74,6	-	216	38	R _p 1/8	-	57	82,4	160	62 000	44 000	-
-	66	216	38	R _p 1/8	96	57	82,6	160	62 000	44 000	-
74,6	-	216	38	R _p 1/8	-	57	82,4	160	62 000	44 000	-
-	67	216	38	R _p 1/8	100	57	83,6	160	62 000	44 500	-
-	67	216	38	R _p 1/8	100	57	83,6	160	62 000	44 500	-
77,8	-	216	38	R _p 1/8	-	57	82,5	160	62 000	44 500	-



Two-bolt flanged housing units with centring spigot

Cast iron housings

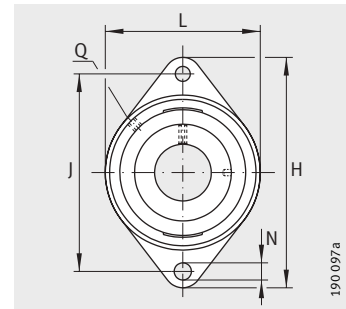

RCJTZ

Dimension table · Dimensions in mm								
Designation			Mass m ≈ kg	Dimensions				
Unit	Housing	Radial insert ball bearing		d	L	H	A ₁	N
RCJTZ20	GG.CJZ04	GE20-KRR-B	0,53	20	60,5	112,5	10	11,5
RCJTZ25	GG.CJZ05	GE25-KRR-B	0,64	25	70	124	12	11,5
RCJTZ30	GG.CJZ06	GE30-KRR-B	0,9	30	83	142	12	11,5
RCJTZ35	GG.CJZ07	GE35-KRR-B	1,22	35	94	155	12,5	14
RCJTZ40	GG.CJZ08	GE40-KRR-B	1,69	40	105	172	13	14
RCJTZ45	GG.CJZ09	GE45-KRR-B	1,86	45	111	180	13	14
RCJTZ50	GG.CJZ10	GE50-KRR-B	2,21	50	116	190	13	14
RCJTZ60	GG.CJZ12	GE60-KRR-B	3,74	60	138	238	16	18

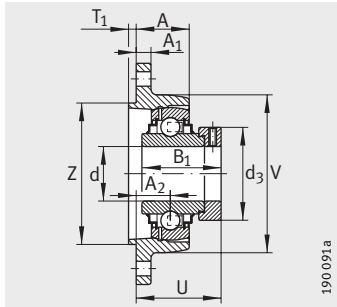

RCJTZ

										Basic load ratings	
B ₁	J	A ₂	Q	d ₃ max.	A	T ₁	U	V	Z h8	dyn. C _r N	stat. C _{0r} N
43,7	90	19	R _p 1/8	33	31,7	3,5	45,6	60,5	55	12 800	6 500
44,5	99	19	R _p 1/8	37,5	26,5	3,5	45,9	70	60	14 000	7 800
48,5	116,5	17	R _p 1/8	44	26	3	47,1	83	80	19 500	11 300
51,3	130	17	R _p 1/8	51	26,5	4	49,3	94	90	25 500	15 300
56,5	143,5	20	R _p 1/8	58	30,5	4	54,9	105	100	32 500	19 800
56,5	148,5	20	R _p 1/8	63	31	4	54,9	111	105	32 500	20 400
62,8	157	24	R _p 1/8	69	35	4	62,1	116	105	35 000	23 200
77,9	202	30	R _p 1/8	84	42	4	76,8	138	130	52 000	36 000



Three-bolt flanged housing units

Cast iron housings

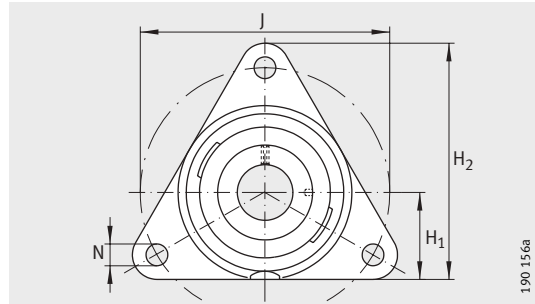

PCFTR

Dimension table · Dimensions in mm							
Designation			Mass m ≈ kg	Dimensions			
Unit	Housing	Radial insert ball bearing		d	H ₂	H ₁	A ₁
PCFTR12	GG.CFTR03	GRAE12-NPP-B	0,4	12	81	31	11
PCFTR15	GG.CFTR03	GRAE15-NPP-B	0,4	15	81	31	11
PCFTR17	GG.CFTR03	GRAE17-NPP-B	0,4	17	81	31	11
PCFTR20	GG.CFTR04	GRAE20-NPP-B	0,56	20	92	35	11
PCFTR25	GG.CFTR05	GRAE25-NPP-B	0,71	25	97	36	12
PCFTR30	GG.CFTR06	GRAE30-NPP-B	0,99	30	117	44	12
PCFTR35	GG.CFTR07	GRAE35-NPP-B	1,34	35	128	48	14
PCFTR40	GG.CFTR08	GRAE40-NPP-B	1,83	40	137	51	16
PCFTR45	GG.CFTR09	GRAE45-NPP-B	2	45	150	55	16
PCFTR50	GG.CFTR10	GRAE50-NPP-B	2,15	50	150	55	16

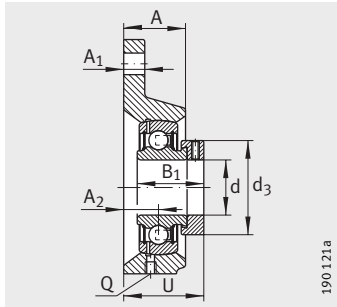

PCFTR

								Basic load ratings	
N	B ₁	J	A ₂	Q	d ₃ max.	A	U	dyn. C _r N	stat. C _{0r} N
11,5	28,6	76,1	10	M6	28	20	32,1	9 800	4 750
11,5	28,6	76,1	10	M6	28	20	32,1	9 800	4 750
11,5	28,6	76,1	10	M6	28	20	32,1	9 800	4 750
11,5	31	89,5	10,5	R _p 1/8	33	20	34	12 800	6 600
11,5	31	96	12,5	R _p 1/8	37,5	22	36	14 000	7 800
11,5	35,8	116	13,3	R _p 1/8	44	24	40	19 500	11 300
14	39	129,7	15,6	R _p 1/8	51	27	45,1	25 500	15 300
14	43,8	140	18,3	R _p 1/8	58	30	51	32 500	19 800
14	43,8	160	19,2	R _p 1/8	63	33	51,9	32 500	20 400
14	43,8	160	19,2	R _p 1/8	69	33	51,9	35 000	23 200



Four-bolt flanged housing units

Cast iron housings

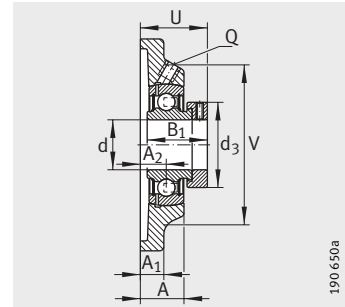
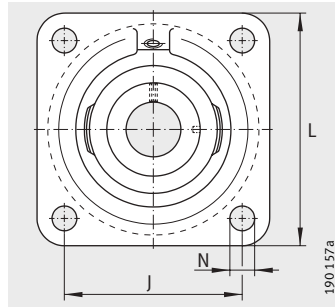

PCF, PCJ (-N-FA125),
RCJ (-N-FA125, -FA164), TCJ,
PCJY, RCJY, RCJY...-JIS

PCF

Dimension table · Dimensions in mm							
Designation			Mass m ≈kg	Dimensions			
Unit	Housing	Radial insert ball bearing		d	L	A ₁	N
PCJ12	GG.CJ03	GRAE12-NPP-B	0,52	12	76	9,5	11,5
PCJY12	GG.CJ03	GAY12-NPP-B	0,5	12	76	9,5	11,5
RCJY12	GG.CJ03	GYE12-KRR-B	0,51	12	76	9,5	11,5
PCJ15	GG.CJ03	GRAE15-NPP-B	0,52	15	76	9,5	11,5
PCJY15	GG.CJ03	GAY15-NPP-B	0,49	15	76	9,5	11,5
RCJY15	GG.CJ03	GYE15-KRR-B	0,51	15	76	9,5	11,5
RCJY16	GG.CJ03	GYE16-KRR-B	0,51	16	76	9,5	11,5
PCJ17	GG.CJ03	GRAE17-NPP-B	0,52	17	76	9,5	11,5
RCJ17	GG.CJ03	GE17-KRR-B	0,56	17	76	9,5	11,5
PCJY17	GG.CJ03	GAY17-NPP-B	0,48	17	76	9,5	11,5
RCJY17	GG.CJ03	GYE17-KRR-B	0,51	17	76	9,5	11,5
PCF20	GG.CF04	GRAE20-NPP-B	0,55	20	86	10	11,5
PCJ20-N	GG.CJ04-N	GRAE20-NPP-B	0,61	20	86	10	11,5
PCJ20-N-FA125	GG.CJ04-N-FA125.1	GRAE20-NPP-B-FA125.5	0,61	20	86	10	11,5
RCJ20-N	GG.CJ04-N	GE20-KRR-B	0,65	20	86	10	11,5
RCJ20-N-FA125	GG.CJ04-N-FA125.1	GE20-KRR-B-FA125.5	0,65	20	86	10	11,5
TCJ20-N	GG.CJ04-N	GE20-KTT-B	0,65	20	86	10	11,5
PCJY20-N	GG.CJ04-N	GAY20-NPP-B	0,58	20	86	10	11,5
RCJY20-N	GG.CJ04-N	GYE20-KRR-B	0,62	20	86	10	11,5
RCJY20-JIS	GG.F204	GYE20-KRR-B-FA107	0,6	20	86	12	12
PCF25	GG.CF05	GRAE25-NPP-B	0,71	25	95	11	11,5
PCJ25-N	GG.CJ05-N	GRAE25-NPP-B	0,76	25	95	11	11,5
PCJ25-N-FA125	GG.CJ05-N-FA125.1	GRAE25-NPP-B-FA125.5	0,76	25	95	11	11,5
RCJ25-N	GG.CJ05-N	GE2-KRR-B	0,82	25	95	11	11,5
RCJ25-N-FA125	GG.CJ05-N-FA125.1	GE25-KRR-B-FA125.5	0,82	25	95	11	11,5
RCJ25-FA164 ¹⁾	GG.CJ05-N	GE25-KRR-B-FA164	0,82	25	95	11	11,5
TCJ25-N	GG.CJ05-N	GE25-KTT-B	0,82	25	95	11	11,5
PCJY25-N	GG.CJ05-N	GAY25-NPP-B	0,73	25	95	11	11,5
RCJY25-N	GG.CJ05-N	GYE25-KRR-B	0,77	25	95	11	11,5
RCJY25-JIS	GG.F205	GYE25-KRR-B-FA107	0,76	25	95	14	12

¹⁾ With lubrication nipple DIN 71412-AR 1/8.

²⁾ To be ordered separately.

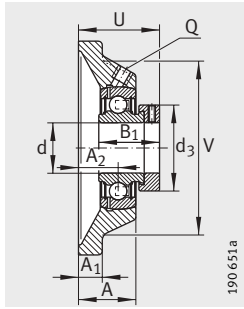

PCJ (-FA125)

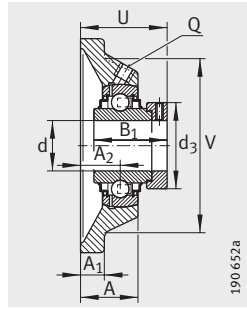

RCJ (-FA125, -FA164),
TCJ

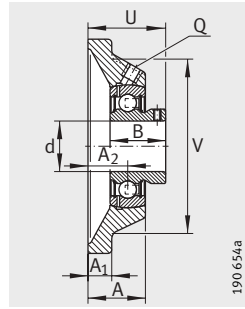

PCJY

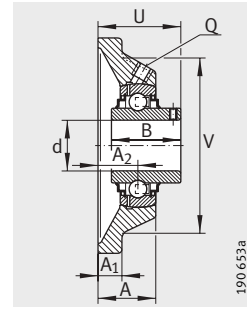

RCJY (-JIS)

B	B ₁	J	A ₂	Q	d ₃ max.	A	U	V	Basic load ratings		End cap ²⁾
									dyn. C _r N	stat. C _{0r} N	
-	28,6	54	17	M6	28	27	39,1	58	9 800	4 750	-
22	-	54	17	M6	-	27	33	58	9 800	4 750	-
27,4	-	54	17	M6	-	27	32,9	58	9 800	4 750	-
-	28,6	54	17	M6	28	27	39,1	58	9 800	4 750	-
22	-	54	17	M6	-	27	33	58	9 800	4 750	-
27,4	-	54	17	M6	-	27	32,9	58	9 800	4 750	-
27,4	-	54	17	M6	-	27	32,9	58	9 800	4 750	-
-	28,6	54	17	M6	28	27	39,1	58	9 800	4 750	-
-	37,4	54	17	M6	28	27	40,4	58	9 800	4 750	-
22	-	54	17	M6	-	27	33	58	9 800	4 750	-
27,4	-	54	17	M6	-	27	32,9	58	9 800	4 750	-
-	31	63,5	10,5	R _p 1/8	33	20	34	68	12 800	6 600	-
-	31	63,5	19	R _p 1/8	33	29	42,5	68	12 800	6 600	KASK04
-	31	63,5	19	R _p 1/8	33	29	42,5	68	12 800	6 600	KASK04
-	43,7	63,5	19	R _p 1/8	33	29	45,6	68	12 800	6 600	KASK04
-	43,7	63,5	19	R _p 1/8	33	29	45,6	68	12 800	6 600	KASK04
-	43,7	63,5	19	R _p 1/8	33	29	45,6	68	12 800	6 600	KASK04
25	-	63,5	19	R _p 1/8	-	29	37	68	12 800	6 600	KASK04
31	-	63,5	19	R _p 1/8	-	29	37,3	68	12 800	6 600	KASK04
31	-	64	15	M6	-	25,5	33,3	-	12 800	6 600	-
-	31	70	12,5	R _p 1/8	37,5	22	36	74	14 000	7 800	-
-	31	70	19	R _p 1/8	37,5	29	42,5	74	14 000	7 800	KASK05
-	31	70	19	R _p 1/8	37,5	29	42,5	74	14 000	7 800	KASK05
-	44,5	70	19	R _p 1/8	37,5	29	45,9	74	14 000	7 800	KASK05
-	44,5	70	19	R _p 1/8	37,5	29	46	74	14 000	7 800	KASK05
-	44,5	70	19	R _p 1/8	37,5	29	46	74	14 000	7 800	-
-	44,5	70	19	R _p 1/8	37,5	29	45,9	74	14 000	7 800	KASK05
27	-	70	19	R _p 1/8	-	29	38,5	74	14 000	7 800	KASK05
34,1	-	70	19	R _p 1/8	-	29	38,8	74	14 000	7 800	KASK05
34,1	-	70	16	M6	-	27	35,8	-	14 000	7 800	-



Four-bolt flanged housing units

Cast iron housings

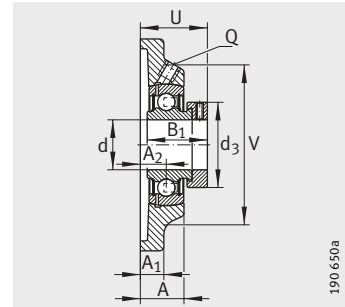
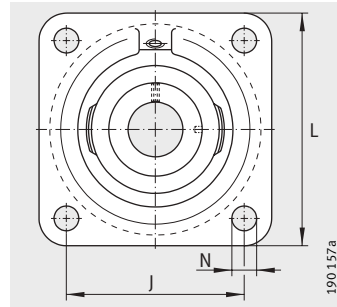

PCF, PCJ (-N-FA125),
RCJ (-N-FA125, -FA164), RCJO,
TCJ, PCJY, RCJY, RCJY (-JIS), RCJL

PCF

Dimension table (continued) · Dimensions in mm

Designation			Mass m ≈kg	Dimensions			
Unit	Housing	Radial insert ball bearing		d	L	A ₁	N
PCF30	GG.CF06	GRAE30-NPP-B	1,01	30	108	12	11,5
PCJ30-N	GG.CJ06-N	GRAE30-NPP-B	1,09	30	108	12	11,5
PCJ30-N-FA125	GG.CJ06-N-FA125.1	GRAE30-NPP-B-FA125.5	1,09	30	108	12	11,5
RCJ30-N	GG.CJ06-N	GE30-KRR-B	1,16	30	108	12	11,5
RCJ30-N-FA125	GG.CJ06-N-FA125.1	GE30-KRR-B-FA125.5	1,16	30	108	12	11,5
TCJ30-N	GG.CJ06-N	GE30-KTT-B	1,16	30	108	12	11,5
RCJL30-N	GG.CJ06-N	GLE30-KRR-B	1,08	30	108	12	11,5
RCJO30	GG.CJ006	GNE30-KRR-B	1,75	30	125	15	14,5
PCJY30-N	GG.CJ06-N	GAY30-NPP-B	1,03	30	108	12	11,5
RCJY30-N	GG.CJ06-N	GYE30-KRR-B	1,11	30	108	12	11,5
RCJY30-JIS	GG.F206	GYE30-KRR-B-FA107	1,17	30	108	14	12
PCF35	GG.CF07	GRAE35-NPP-B	1,37	35	118	12,5	14
PCJ35-N	GG.CJ07-N	GRAE35-NPP-B	1,4	35	118	12,5	14
PCJ35-N-FA125	GG.CJ07-N-FA125.1	GRAE35-NPP-B-FA125.5	1,4	35	118	12,5	14
RCJ35-N	GG.CJ07-N	GE35-KRR-B	1,47	35	118	12,5	14
RCJ35-N-FA125	GG.CJ07-N-FA125.1	GE35-KRR-B-FA125.5	1,47	35	118	12,5	14
RCJ35-FA164 ¹⁾	GG.CJ07-N	GE35-KRR-B-FA164	1,47	35	118	12,5	14
TCJ35-N	GG.CJ07-N	GE35-KTT-B	1,47	35	118	12,5	14
RCJL35-N	GG.CJ07-N	GLE35-KRR-B	1,35	35	118	12,5	14
RCJO35	GG.CJ007	GNE35-KRR-B	2,55	35	135	16	19
PCJY35-N	GG.CJ07-N	GAY35-NPP-B	1,31	35	118	12,5	14
RCJY35-N	GG.CJ07-N	GYE35-KRR-B	1,41	35	118	12,5	14
RCJY35-JIS	GG.F207	GYE35-KRR-B-FA107	1,47	35	117	16	14
PCF40	GG.CF08	GRAE40-NPP-B	1,72	40	130	13	14
PCJ40-N	GG.CJ08-N	GRAE40-NPP-B	1,9	40	130	13	14
PCJ40-N-FA125	GG.CJ08-N-FA125.1	GRAE40-NPP-B-FA125.5	1,9	40	130	13	14
RCJ40-N	GG.CJ08-N	GE40-KRR-B	2,02	40	130	13	14
RCJ40-N-FA125	GG.CJ08-N-FA125.1	GE40-KRR-B-FA125.5	2,02	40	130	13	14
RCJ40-FA164 ¹⁾	GG.CJ08-N	GE40-KRR-B-FA164	2,02	40	130	13	14
TCJ40-N	GG.CJ08-N	GE40-KTT-B	2,02	40	130	13	14
RCJL40-N	GG.CJ08-N	GLE40-KRR-B	1,86	40	130	13	14
RCJO40	GG.CJ008	GNE40-KRR-B	3,1	40	150	17	19
PCJY40-N	GG.CJ08-N	GAY40-NPP-B	1,79	40	130	13	14
RCJY40-N	GG.CJ08-N	GYE40-KRR-B	1,93	40	130	13	14
RCJY40-JIS	GG.F208	GYE40-KRR-B-FA107	1,91	40	130	16	16

¹⁾ With lubrication nipple DIN 71412-AR 1/8.

²⁾ To be ordered separately.

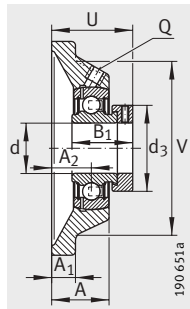

PCJ (-N-FA125)

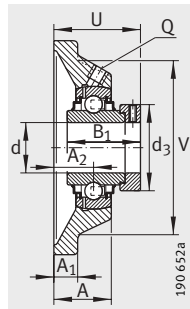

RCJ (-N-FA125, -FA164), RCJO, TCJ

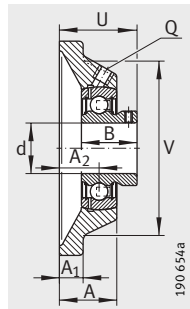

PCJY

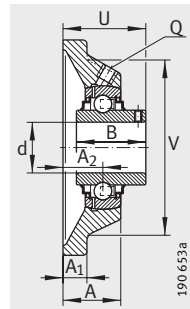

RCJY (-JIS)

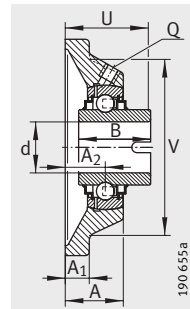

RCJL

B	B ₁	J	A ₂	Q	d ₃ max.	A	U	V	Basic load ratings		End cap ²⁾
									dyn. C _r N	stat. C _{0r} N	
-	35,8	82,5	13,3	R _p 1/8	44	22,3	40	85	19 500	11 300	-
-	35,8	82,5	20	R _p 1/8	44	29	46,7	85	19 500	11 300	KASK06
-	35,8	82,5	20	R _p 1/8	44	29	46,7	85	19 500	11 300	KASK06
-	48,5	82,5	20	R _p 1/8	44	29	50,1	85	19 500	11 300	KASK06
-	48,5	82,5	20	R _p 1/8	44	29	50,1	85	19 500	11 300	KASK06
-	48,5	82,5	20	R _p 1/8	44	29	50,1	85	19 500	11 300	KASK06
36,5	-	82,5	20	R _p 1/8	-	29	42	85	19 500	11 300	KASK06
-	50	95	20,6	R _p 1/8	51	30,6	53,1	98	29 500	16 700	-
30	-	82,5	20	R _p 1/8	-	29	41	85	19 500	11 300	KASK06
38,1	-	82,5	20	R _p 1/8	-	29	42,2	85	19 500	11 300	KASK06
38,1	-	83	18	M6	-	31	40,2	-	19 500	11 300	-
-	39	92	15,5	R _p 1/8	51	25	44,9	100	25 500	15 300	-
-	39	92	21	R _p 1/8	51	30,5	50,4	100	25 500	15 300	KASK07
-	39	92	21	R _p 1/8	51	30,5	50,4	100	25 500	15 300	KASK07
-	51,3	92	21	R _p 1/8	51	30,5	53,3	100	25 500	15 300	KASK07
-	51,3	92	21	R _p 1/8	51	30,5	53,3	100	25 500	15 300	KASK07
-	51,3	92	21	R _p 1/8	51	30,5	53,4	100	25 500	15 300	-
-	51,3	92	21	R _p 1/8	51	30,5	53,3	100	25 500	15 300	KASK07
37,7	-	92	21	R _p 1/8	-	30,5	43	100	25 500	15 300	KASK07
-	51,6	100	20	R _p 1/8	55	31	53,4	104	36 500	20 900	-
35	-	92	21	R _p 1/8	-	30,5	46,5	100	25 500	15 300	KASK07
42,9	-	92	21	R _p 1/8	-	30,5	46,4	100	25 500	15 300	KASK07
42,9	-	92	19	M6	-	34	44,4	-	25 500	15 300	-
-	43,8	101,5	18,3	R _p 1/8	58	28,8	51	110	32 500	19 800	-
-	43,8	101,5	24	R _p 1/8	58	34,5	56,7	110	32 500	19 800	KASK08
-	43,8	101,5	24	R _p 1/8	58	34,5	56,7	110	32 500	19 800	KASK08
-	56,5	101,5	24	R _p 1/8	58	34,5	58,1	110	32 500	19 800	KASK08
-	56,5	101,5	24	R _p 1/8	58	34,5	59,1	110	32 500	19 800	KASK08
-	56,5	101,5	24	R _p 1/8	58	34,5	59,1	110	32 500	19 800	-
-	56,5	101,5	24	R _p 1/8	58	34,5	58,1	110	32 500	19 800	KASK08
42,9	-	101,5	24	R _p 1/8	-	34,5	51	110	32 500	19 800	KASK08
-	54,6	112	23	R _p 1/8	63	34,5	59,6	121	44 500	26 000	-
39,5	-	101,5	24	R _p 1/8	-	34,5	53	110	32 500	19 800	KASK08
49,2	-	101,5	24	R _p 1/8	-	34,5	54,2	110	32 500	19 800	KASK08
49,2	-	102	21	M6	-	36	51,2	-	32 500	19 800	-



Four-bolt flanged housing units

Cast iron housings

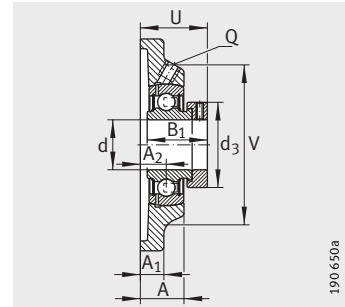
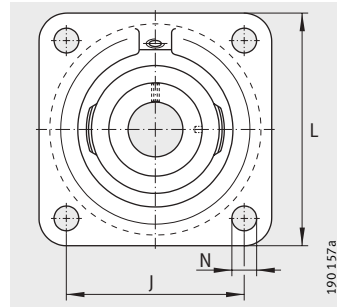

PCF, PCJ (-N-FA125, -FA125),
RCJ (-N-FA125, -FA125, -FA164),
RCJO, TCJ, PCJY, RCJY (-JIS), RCJL

PCF

Dimension table (continued) · Dimensions in mm							
Designation			Mass m ≈kg	Dimensions			
Unit	Housing	Radial insert ball bearing		d	L	A ₁	N
PCF45	GG.CF09	GRAE45-NPP-B	1,99	45	137	13	14
PCJ45	GG.CJ09	GRAE45-NPP-B	2,22	45	137	13	14
PCJ45-FA125	GG.CJ09-FA125.1	GRAE45-NPP-B-FA125.5	2,22	45	137	13	14
RCJ45	GG.CJ09	GE45-KRR-B	2,26	45	137	13	14
RCJ45-FA125	GG.CJ09-FA125.1	GE45-KRR-B-FA125.5	2,26	45	137	13	14
TCJ45	GG.CJ09	GE45-KTT-B	2,31	45	137	13	14
PCJY45	GG.CJ09	GAY45-NPP-B	2	45	137	13	14
RCJY45	GG.CJ09	GYE45-KRR-B	2,15	45	137	13	14
RCJY45-JIS	GG.F209	GYE45-KRR-B-FA107	2,28	45	137	18	16
PCF50	GG.CF10	GRAE50-NPP-B	2,2	50	143	13	14
PCJ50-N	GG.CJ10-N	GRAE50-NPP-B	2,3	50	143	13	18
PCJ50-N-FA125	GG.CJ10-N-FA125.1	GRAE50-NPP-B-FA125.5	2,3	50	143	13	18
RCJ50-N	GG.CJ10-N	GE50-KRR-B	2,53	50	143	13	18
RCJ50-N-FA125	GG.CJ10-N-FA125.1	GE50-KRR-B-FA125.5	2,53	50	143	13	18
RCJ50-FA164 ¹⁾	GG.CJ10-N	GE50-KRR-B-FA164	2,53	50	143	13	18
TCJ50-N	GG.CJ10-N	GE50-KTT-B	2,53	50	143	13	18
RCJL50-N	GG.CJ10-N	GLE50-KRR-B	2,29	50	143	13	18
RCJO50	GG.CJO10	GNE50-KRR-B	4,9	50	175	19	23
PCJY50-N	GG.CJ10-N	GAY50-NPP-B	2,15	50	143	13	18
RCJY50-N	GG.CJ10-N	GYE50-KRR-B	2,33	50	143	13	18
RCJY50-JIS	GG.F210	GYE50-KRR-B-FA107	2,54	50	143	18	16
PCJ55	GG.CJ11	GRAE55-NPP-B	2,91	55	162	15	18
RCJ55	GG.CJ11	GE55-KRR-B	3,52	55	162	15	18
TCJ55	GG.CJ11	GE55-KTT-B	3,57	55	162	15	18
RCJY55	GG.CJ11	GYE55-KRR-B	3,2	55	162	15	18
RCJY55-JIS	GG.F211	GYE55-KRR-B-FA107	3,3	55	162	20	19
PCJ60-N	GG.CJ12-N	GRAE60-NPP-B	4,1	60	175	16	18
RCJ60-N	GG.CJ12-N	GE60-KRR-B	4,54	60	175	16	18
RCJ60-FA164 ¹⁾	GG.CJ12-N	GE60-KRR-B-FA164	4,54	60	175	16	18
TCJ60-N	GG.CJ12-N	GE60-KTT-B	4,54	60	175	16	18
RCJL60-N	GG.CJ12-N	GLE60-KRR-B	4,22	60	175	16	18
RCJO60	GG.CJO12	GNE60-KRR-B	6,8	60	195	22	23
PCJY60-N	GG.CJ12-N	GAY60-NPP-B	4,02	60	175	16	18
RCJY60-N	GG.CJ12-N	GYE60-KRR-B	4,22	60	175	16	18
RCJY60-JIS	GG.F212	GYE60-KRR-B-FA107	4,22	60	175	20	19

¹⁾ With lubrication nipple DIN 71412-AR 1/8.

²⁾ To be ordered separately.

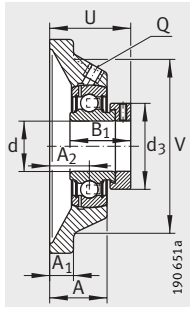

PCJ (-N-FA125,
-FA125)

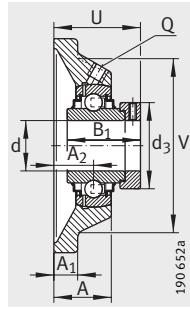

RCJ (-N-FA125,
-FA125, -FA164),
RCJO, TCJ

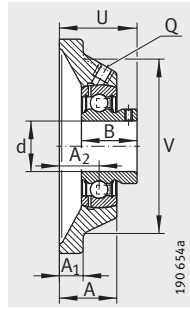

PCJY

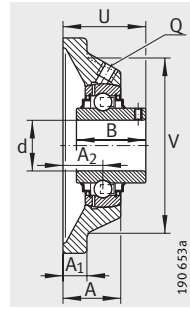

RCJY (-JIS)

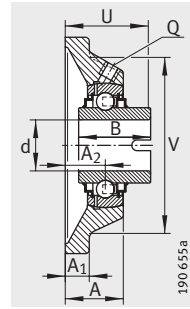

RCJL

									Basic load ratings		End cap ²⁾
B	B ₁	J	A ₂	Q	d ₃ max.	A	U	V	dyn. C _r N	stat. C _{0r} N	
-	43,8	105	19,2	R _p 1/8	63	30,2	51,9	116	32 500	20 400	-
-	43,8	105	24	R _p 1/8	63	35	56,7	116	32 500	20 400	-
-	43,8	105	24	R _p 1/8	63	35	56,7	116	32 500	20 400	-
-	56,5	105	24	R _p 1/8	63	35	58,1	116	32 500	20 400	-
-	56,5	105	24	R _p 1/8	63	35	59,1	116	32 500	20 400	-
-	56,5	105	24	R _p 1/8	63	35	58,1	116	32 500	20 400	-
41,5	-	105	24	R _p 1/8	-	35	54,5	116	32 500	20 400	-
49,2	-	105	24	R _p 1/8	-	35	54,2	116	32 500	20 400	-
49,2	-	105	22	M6	-	38	52,2	-	32 500	20 400	-
-	43,8	111	19,2	R _p 1/8	69	30,2	51,4	125	35 000	23 200	-
-	43,8	111	28	R _p 1/8	69	39	60,7	125	35 000	23 200	KASK10
-	43,8	111	28	R _p 1/8	69	39	60,7	125	35 000	23 200	KASK10
-	62,8	111	28	R _p 1/8	69	39	66,1	125	35 000	23 200	KASK10
-	62,8	111	28	R _p 1/8	69	39	66,1	125	35 000	23 200	KASK10
-	62,8	111	28	R _p 1/8	69	39	66,1	125	35 000	23 200	-
-	62,8	111	28	R _p 1/8	69	39	66,1	125	35 000	23 200	KASK10
49,2	-	111	28	R _p 1/8	-	39	58,2	125	35 000	23 200	KASK10
-	66,8	132	28	R _p 1/8	75,8	42,5	70,1	144	62 000	38 000	-
43	-	111	28	R _p 1/8	-	39	60	125	35 000	23 200	KASK10
51,6	-	111	28	R _p 1/8	-	39	60,6	125	35 000	23 200	KASK10
51,6	-	111	22	M6	-	40	54,6	-	35 000	23 200	-
-	48,4	130	31	R _p 1/8	76	43,5	67,4	140	43 500	29 000	-
-	71,4	130	31	R _p 1/8	76	43,5	74,6	140	43 500	29 000	-
-	71,4	130	31	R _p 1/8	76	43,5	74,6	140	43 500	29 000	-
55,6	-	130	31	R _p 1/8	-	43,5	64,4	140	43 500	29 000	-
55,6	-	130	25	M6	-	43	58,4	-	43 500	29 000	-
-	53,1	143	34	R _p 1/8	84	46	73,6	150	52 000	36 000	KASK12
-	77,9	143	34	R _p 1/8	84	46	80,8	150	52 000	36 000	KASK12
-	77,9	143	34	R _p 1/8	84	46	81	150	52 000	36 000	-
-	77,9	143	34	R _p 1/8	84	46	80,8	150	52 000	36 000	KASK12
61,9	-	143	34	R _p 1/8	-	46	71,3	150	52 000	36 000	KASK12
-	68,4	150	33	R _p 1/8	89	49,5	78,4	170	82 000	52 000	-
47	-	143	34	R _p 1/8	-	46	68	150	52 000	36 000	KASK12
65,1	-	143	34	R _p 1/8	-	46	73,7	150	52 000	36 000	KASK12
65,1	-	143	29	M6	-	48	68,7	-	52 000	36 000	-



Four-bolt flanged housing units

Cast iron housings

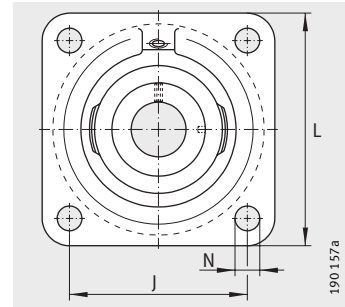

RCJ (-FA164), RCJO, TCJ,
RCJL, RCJY

Dimension table (continued) · Dimensions in mm							
Designation			Mass m ≈kg	Dimensions			
Unit	Housing	Radial insert ball bearing		d	L	A ₁	N
RCJ65	GG.CJ14	GE65-214-KRR-B	6,11	65	188	18	18
RCJ65-FA164 ¹⁾	GG.CJ14	GE65-214-KRR-B-FA164	6,11	65	188	18	18
TCJ65	GG.CJ14	GE65-214-KTT-B	6,11	65	188	18	18
RCJY65	GG.CJ14	GYE65-214-KRR-B	5,65	65	188	18	18
RCJ70	GG.CJ14	GE70-KRR-B	5,85	70	188	18	18
TCJ70	GG.CJ14	GE70-KTT-B	5,85	70	188	18	18
RCJL70	GG.CJ14	GLE70-KRR-B	5,65	70	188	18	18
RCJO70	GG.CJO14	GNE70-KRR-B	10	70	226	25	25
RCJY70	GG.CJ14	GYE70-KRR-B	5,35	70	188	18	18
RCJ75	GG.CJ15	GE75-KRR-B	6,5	75	197	20	23
TCJ75	GG.CJ15	GE75-KTT-B	6,5	75	197	20	23
RCJY75	GG.CJ15	GYE75-KRR-B	6,04	75	197	20	23
RCJ80	GG.CJ16	GE80-KRR-B	6,85	80	197	20	23
TCJ80	GG.CJ16	GE80-KTT-B	6,85	80	197	20	23
RCJO80	GG.CJO16	GNE80-KRR-B	17,15	80	250	25	28
RCJY80	GG.CJ16	GYE80-KRR-B	6,82	80	197	20	23
RCJ90	GG.CJ18	GE90-KRR-B	9	90	235	22	23
RCJO90	GG.CJO18	GNE90-KRR-B	21,6	90	280	28,5	28
RCJY90	GG.CJ18	GYE90-KRR-B	9,48	90	235	22	23
RCJ100	GG.CJ20	GE100-KRR-B	12,25	100	265	25	27
RCJO100	GG.CJO20	GNE100-KRR-B	33,6	100	310	32	32
RCJ120	GG.CJ24	GE120-KRR-B	18	120	305	28	30

¹⁾ With lubrication nipple DIN 71412-AR 1/8.

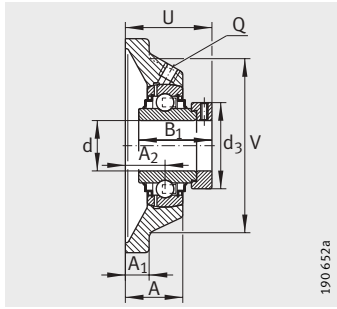

RCJ (-FA164), RCJO, TCJ

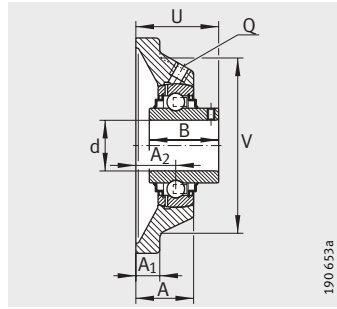

RCJY

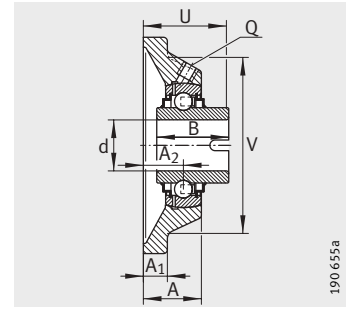

RCJL

									Basic load ratings	
B	B ₁	J	A ₂	Q	d ₃ max.	A	U	V	dyn. C _r N	stat. C _{0r} N
-	66	150	38	R _p 1/8	96	52	82,6	165	62 000	44 000
-	66	150	38	R _p 1/8	96	52	82,6	165	62 000	44 000
-	66	150	38	R _p 1/8	96	52	82,6	165	62 000	44 000
74,6	-	150	38	R _p 1/8	-	52	82,4	165	62 000	44 000
-	66	150	38	R _p 1/8	96	52	82,6	165	62 000	44 000
-	66	150	38	R _p 1/8	96	52	82,6	165	62 000	44 000
68,2	-	150	38	R _p 1/8	-	52	79,2	165	62 000	44 000
-	75,4	178	36	R _p 1/8	102	54,5	85,4	196	104 000	68 000
74,6	-	150	38	R _p 1/8	-	52	82,4	165	62 000	44 000
-	67	153	41,3	R _p 1/8	100	55,8	86,9	170	62 000	44 500
-	67	153	41,3	R _p 1/8	100	55,8	86,9	170	62 000	44 500
77,8	-	153	41,3	R _p 1/8	-	55,8	85,8	170	62 000	44 500
-	70,7	153	41,3	R _p 1/8	108	55,8	88,9	180	72 000	54 000
-	70,7	153	41,3	R _p 1/8	108	55,8	88,9	180	72 000	54 000
-	93,6	196	50	R _p 1/8	118	80	109,7	210	123 000	87 000
82,6	-	153	41,3	R _p 1/8	-	55,8	90,6	180	72 000	54 000
-	69,5	187	23,8	R _p 1/8	118	39,8	70,3	200	96 000	72 000
-	101	216	48,5	R _p 1/8	132	85	114	230	143 000	107 000
96	-	187	23,8	R _p 1/8	-	39,8	80,1	200	96 000	72 000
-	75	210	28	R _p 1/8	132	46	77,5	230	122 000	93 000
-	109,5	242	55	R _p 1/8	145	97	125	268	174 000	140 000
-	81	240	31	R _p 1/8	152	51	83	270	155 000	131 000



Four-bolt flanged housing units with centring spigot

Cast iron housings

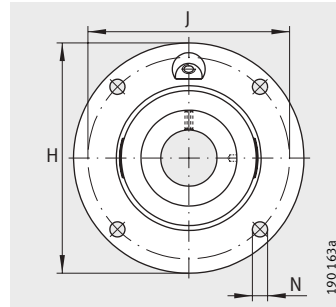

PME, RME, RME0, TME, PMEY, RMEY

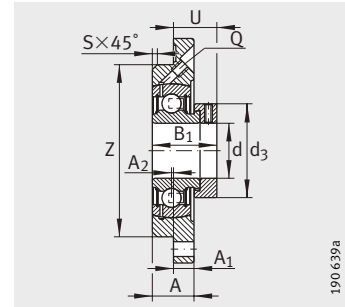

PME

Dimension table · Dimensions in mm							
Designation			Mass m ≈kg	Dimensions			
Unit	Housing	Radial insert ball bearing		d	H	A ₁	N
PME20-N	GG.ME04-N	GRAE20-NPP-B	0,53	20	100	8	9
RME20-N	GG.ME04-N	GE20-KRR-B	0,57	20	100	8	9
TME20-N	GG.ME04-N	GE20-KTT-B	0,57	20	100	8	9
PMEY20-N	GG.ME04-N	GAY20-NPP-B	0,5	20	100	8	9
RMEY20-N	GG.ME04-N	GYE20-KRR-B	0,54	20	100	8	9
PME25-N	GG.ME05-N	GRAE25-NPP-B	0,74	25	115	9	9
RME25-N	GG.ME05-N	GE25-KRR-B	0,8	25	115	9	9
TME25-N	GG.ME05-N	GE25-KTT-B	0,8	25	115	9	9
PMEY25-N	GG.ME05-N	GAY25-NPP-B	0,71	25	115	9	9
RMEY25-N	GG.ME05-N	GYE25-KRR-B	0,75	25	115	9	9
PME30-N	GG.ME06-N	GRAE30-NPP-B	0,97	30	125	9,5	11,5
RME30-N	GG.ME06-N	GE30-KRR-B	1,04	30	125	9,5	11,5
TME30-N	GG.ME06-N	GE30-KTT-B	1,05	30	125	9,5	11,5
PMEY30-N	GG.ME06-N	GAY30-NPP-B	0,91	30	125	9,5	11,5
RMEY30-N	GG.ME06-N	GYE30-KRR-B	0,99	30	125	9,5	11,5
PME35-N	GG.ME07-N	GRAE35-NPP-B	1,27	35	135	10	11,5
RME35-N	GG.ME07-N	GE35-KRR-B	1,34	35	135	10	11,5
TME35-N	GG.ME07-N	GE35-KTT-B	1,35	35	135	10	11,5
RME035	GG.ME007	GNE35-KRR-B	2,4	35	174	16	19
PMEY35-N	GG.ME07-N	GAY35-NPP-B	1,18	35	135	10	11,5
RMEY35-N	GG.ME07-N	GYE35-KRR-B	1,28	35	135	10	11,5
PME40-N	GG.ME08-N	GRAE40-NPP-B	1,62	40	145	11,5	11,5
RME40-N	GG.ME08-N	GE40-KRR-B	1,74	40	145	11,5	11,5
TME40-N	GG.ME08-N	GE40-KTT-B	1,77	40	145	11,5	11,5
RME040	GG.ME008	GNE40-KRR-B	3,4	40	194	17	19
PMEY40-N	GG.ME08-N	GAY40-NPP-B	1,51	40	145	11,5	11,5
RMEY40-N	GG.ME08-N	GYE40-KRR-B	1,65	40	145	11,5	11,5
PME45	GG.ME09	GRAE45-NPP-B	1,93	45	155	12	14
RME45	GG.ME09	GE45-KRR-B	2,05	45	155	12	14
TME45	GG.ME09	GE45-KTT-B	2,1	45	155	12	14
PMEY45	GG.ME09	GAY45-NPP-B	1,79	45	155	12	14
RMEY45	GG.ME09	GYE45-KRR-B	1,94	45	155	12	14

¹⁾ To be ordered separately.

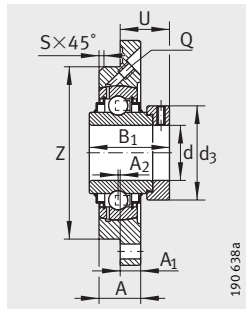

RME, RMEO

190 638a

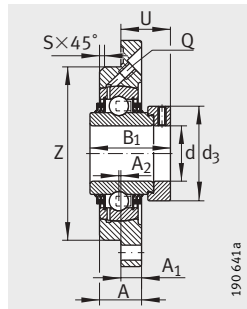

TME

190 641a

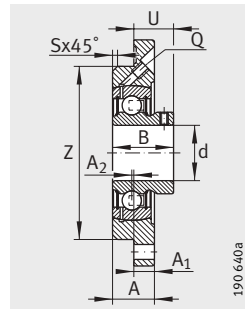

PMEY

190 640a

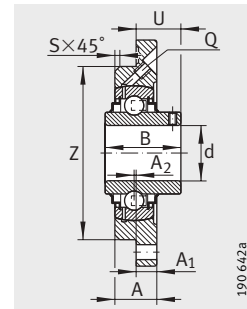

RMEY

190 642a

B	B ₁	J	A ₂	Q	d ₃ max.	S	A	U	Z h8	Basic load ratings		End cap ¹⁾
										dyn. C _r N	stat. C _{0r} N	
-	31	78	2	M6	33	2	17	21,5	62	12 800	6 600	KASK04
-	43,7	78	2	M6	33	2	17	24,6	62	12 800	6 600	KASK04
-	43,7	78	2	M6	33	2	17	24,6	62	12 800	6 600	KASK04
25	-	78	2	M6	-	2	17	16	62	12 800	6 600	KASK04
31	-	78	2	M6	-	2	17	16,3	62	12 800	6 600	KASK04
-	31	90	2,5	M6	37,5	2	19	21	70	14 000	7 800	KASK05
-	44,5	90	2,5	M6	37,5	2	19	24,4	70	14 000	7 800	KASK05
-	44,5	90	2,5	M6	37,5	2	19	24,4	70	14 000	7 800	KASK05
27	-	90	2,5	M6	-	2	19	17	70	14 000	7 800	KASK05
34,1	-	90	2,5	M6	-	2	19	17,3	70	14 000	7 800	KASK05
-	35,8	100	2	M6	44	2	20,5	24,7	80	19 500	11 300	KASK06
-	48,5	100	2	M6	44	2	20,5	28,1	80	19 500	11 300	KASK06
-	48,5	100	2	M6	44	2	20,5	28,1	80	19 500	11 300	KASK06
30	-	100	2	M6	-	2	20,5	19	80	19 500	11 300	KASK06
38,1	-	100	2	M6	-	2	20,5	20,2	80	19 500	11 300	KASK06
-	39	110	1	M6	51	2	20,5	28,4	90	25 500	15 300	KASK07
-	51,3	110	1	M6	51	2	20,5	31,3	90	25 500	15 300	KASK07
-	51,3	110	1	M6	51	2	20,5	31,3	90	25 500	15 300	KASK07
-	51,6	141	-2	M6	55	2	25	25,4	100	36 500	20 900	-
35	-	110	1	M6	-	2	20,5	24,5	90	25 500	15 300	KASK07
42,9	-	110	1	M6	-	2	20,5	24,4	90	25 500	15 300	KASK07
-	43,8	120	1	M6	58	2	23	31,7	100	32 500	19 800	KASK08
-	56,5	120	1	M6	58	2	23	33,9	100	32 500	19 800	KASK08
-	56,5	120	1	M6	58	2	23	33,9	100	32 500	19 800	KASK08
-	54,6	158	-2,5	M6	63	2	27	39,1	115	44 500	26 000	-
39,5	-	120	1	M6	-	2	23	28	100	32 500	19 800	KASK08
49,2	-	120	1	M6	-	2	23	29,2	100	32 500	19 800	KASK08
-	43,8	130	2	M6	63	2	25	30,7	105	32 500	20 400	-
-	56,5	130	2	M6	63	2	25	32,9	105	32 500	20 400	-
-	56,5	130	2	M6	63	2	25	32,9	105	32 500	20 400	-
41,5	-	130	2	M6	-	2	25	28,5	105	32 500	20 400	-
49,2	-	130	2	M6	-	2	25	28,2	105	32 500	20 400	-



Four-bolt flanged housing units with centring spigot

Cast iron housings

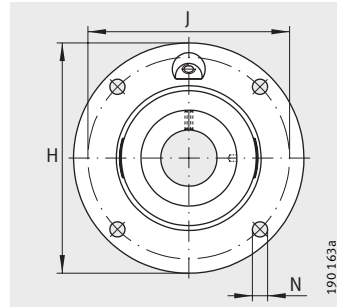

PME, RME, RME0, TME, PMEY, RMEY

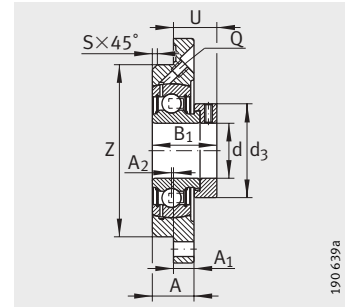

PME

Dimension table (continued) · Dimensions in mm							
Designation			Mass m ≈ kg	Dimensions			
Unit	Housing	Radial insert ball bearing		d	H	A ₁	N
PME50-N	GG.ME10-N	GRAE50-NPP-B	2,3	50	165	13	14
RME50-N	GG.ME10-N	GE50-KRR-B	2,53	50	165	13	14
TME50-N	GG.ME10-N	GE50-KTT-B	2,59	50	165	13	14
RME050	GG.MEO10	GNE50-KRR-B	4,6	50	230	19	23
PMEY50-N	GG.ME10-N	GAY50-NPP-B	2,15	50	165	13	14
RMEY50-N	GG.ME10-N	GYE50-KRR-B	2,33	50	165	13	14
PME55	GG.ME11	GRAE55-NPP-B	2,76	55	185	15	18
RME55	GG.ME11	GE55-KRR-B	3,37	55	185	15	18
TME55	GG.ME11	GE55-KTT-B	3,43	55	185	15	18
RMEY55	GG.ME11	GYE55-KRR-B	3,05	55	185	15	18
PME60-N	GG.ME12-N	GRAE60-NPP-B	3,55	60	195	16	18
RME60-N	GG.ME12-N	GE60-KRR-B	3,99	60	195	16	18
TME60-N	GG.ME12-N	GE60-KTT-B	4,1	60	195	16	18
RME060	GG.MEO12	GNE60-KRR-B	6	60	256	22	23
PMEY60-N	GG.ME12-N	GAY60-NPP-B	3,22	60	195	16	18
RMEY60-N	GG.ME12-N	GYE60-KRR-B	3,47	60	195	16	18
RME65	GG.ME14	GE65-214-KRR-B	5,81	65	215	18	18
TME65	GG.ME14	GE65-214-KTT-B	5,81	65	215	18	18
RMEY65	GG.ME14	GYE65-214-KRR-B	5,35	65	215	18	18
RME70	GG.ME14	GE70-KRR-B	5,55	70	215	18	18
TME70	GG.ME14	GE70-KTT-B	5,66	70	215	18	18
RME070	GG.MEO14	GNE70-KRR-B	9	70	300	25	25
RMEY70	GG.ME14	GYE70-KRR-B	5,1	70	215	18	18
RME75	GG.ME15	GE75-2RSR-B	5,65	75	220	18	18
TME75	GG.ME15	GE75-KTT-B	5,76	75	220	18	18
RMEY75	GG.ME15	GYE75-KRR-B	5,19	75	220	18	18
RME80	GG.ME16	GE80-KRR-B	5,75	80	220	18	18
TME80	GG.ME16	GE80-KTT-B	5,86	80	220	18	18
RME080	GG.MEO16	GNE80-KRR-B-FA107	12,7	80	275	22	22
RMEY80	GG.ME16	GYE80-KRR-B	5,73	80	220	18	18
RME90	GG.ME18	GE90-KRR-B	8,82	90	265	20	23
RME090	GG.MEO18	GNE90-KRR-B-FA107	12,7	90	300	22	22
RMEY90	GG.ME18	GYE90-KRR-B	9,3	90	265	20	23
RME100	GG.ME20	GE100-KRR-B	11,45	100	295	22	23
RME0100	GG.MEO20	GNE100-KRR-B-FA107	22,3	100	340	27	26
RME120	GG.ME24	GE120-KRR-B	17,43	120	350	24	27

1) To be ordered separately.

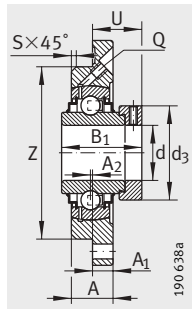

RME, RMEO
(up to d = 70 mm)

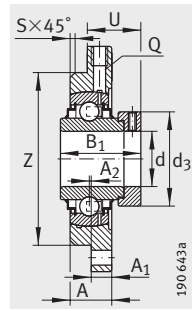

RMEO
(from d = 80 mm)

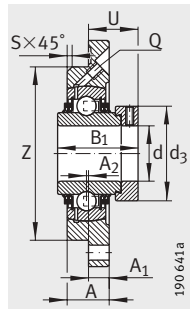

TME

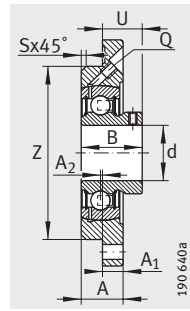

PMEY

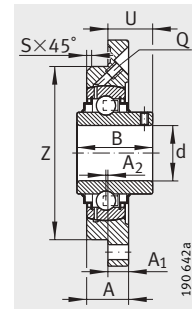

RMEY

										Basic load ratings		End cap ¹⁾
B	B ₁	J	A ₂	Q	d ₃ max.	S	A	U	Z h8	dyn. C _r N	stat. C _{0r} N	
-	43,8	135	1	M8×1	69	3	25	31,7	110	35 000	23 200	KASK10
-	62,8	135	1	M8×1	69	3	25	37,1	110	35 000	23 200	KASK10
-	62,8	135	1	M8×1	69	3	25	37,1	110	35 000	23 200	KASK10
-	66,8	187	-2,5	R _p 1/8	75,8	2	31	44,6	140	62 000	38 000	-
43	-	135	1	M8×1	-	3	25	31	110	35 000	23 200	KASK10
51,6	-	135	1	M8×1	-	3	25	31,6	110	35 000	23 200	KASK10
-	48,4	150	-	M6	76	3	27,5	36,4	125	43 500	29 000	-
-	71,4	150	-	M6	76	3	27,5	43,6	125	43 500	29 000	-
-	71,4	150	-	M6	76	3	27,5	43,6	125	43 500	29 000	-
55,6	-	150	-	M6	-	3	27,5	33,4	125	43 500	29 000	-
-	53,1	160	1	R _p 1/8	84	3	29	38,6	135	52 000	36 000	KASK12
-	77,9	160	1	R _p 1/8	84	3	29	45,8	135	52 000	36 000	KASK12
-	77,9	160	1	R _p 1/8	84	3	29	45,8	135	52 000	36 000	KASK12
-	68,4	212	-2,5	R _p 1/8	89	3	36	47,9	160	82 000	52 000	-
47	-	160	1	R _p 1/8	-	3	29	33	135	52 000	36 000	KASK12
65,1	-	160	1	R _p 1/8	-	3	29	38,7	135	52 000	36 000	KASK12
-	66	177	-	R _p 1/8	96	6	32	44,6	150	62 000	44 000	-
-	66	177	-	R _p 1/8	96	6	32	44,6	150	62 000	44 000	-
74,6	-	177	-	R _p 1/8	-	6	32	44,4	150	62 000	44 000	-
-	66	177	-	R _p 1/8	96	6	32	44,6	150	62 000	44 000	-
-	66	177	-	R _p 1/8	96	6	32	44,6	150	62 000	44 000	-
-	75,5	252	-0,5	R _p 1/8	102	4	43	49,9	185	104 000	68 000	-
74,6	-	177	-	R _p 1/8	-	6	32	44,4	150	62 000	44 000	-
-	67	184	-	R _p 1/8	100	6	32	45,6	160	62 000	44 500	-
-	67	184	-	R _p 1/8	100	6	32	45,6	160	62 000	44 500	-
77,8	-	184	-	R _p 1/8	-	6	32	44,5	160	62 000	44 500	-
-	70,7	184	-2	R _p 1/8	108	6	31	49,6	160	72 000	54 000	-
-	70,7	184	-2	R _p 1/8	108	6	31	49,6	160	72 000	54 000	-
-	93,6	235	3	R _p 1/8	118	6	50	56,7	200	123 000	87 000	-
82,6	-	184	-2	R _p 1/8	-	6	31	51,3	160	72 000	54 000	-
-	69,5	220	-4	R _p 1/8	118	3	32	50,5	190	96 000	72 000	-
-	101	260	3	R _p 1/8	132	6	50	62,5	220	143 000	107 000	-
96	-	220	-4	R _p 1/8	-	3	32	60,3	190	96 000	72 000	-
-	75	245	-4	R _p 1/8	132	3	36	53,4	210	122 000	93 000	-
-	109,4	295	1,5	R _p 1/8	145	8	57	68,5	250	174 000	140 000	-
-	81	295	-4	R _p 1/8	152	3	40	56,5	250	155 000	131 000	-



Four-bolt flanged housing units with centring spigot

Cast iron housings

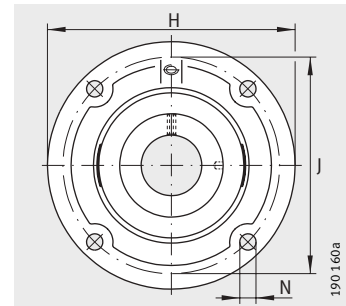

RFE, TFE

Dimension table · Dimensions in mm									
Designation			Mass m ≈ kg	Dimensions					
Unit	Housing	Radial insert ball bearing		d	H	A ₁	N	B ₁	
RFE25	GG.FE05	GE25-KRR-B	0,8	25	115	9	9	44,5	
TFE25	GG.FE05	GE25-KTT-B	0,8	25	115	9	9	44,5	
RFE30	GG.FE06	GE30-KRR-B	1,08	30	127	9,5	9	48,5	
TFE30	GG.FE06	GE30-KTT-B	1,08	30	127	9,5	9	48,5	
RFE35	GG.FE07	GE35-KRR-B	1,3	35	135	10	11,5	51,3	
TFE35	GG.FE07	GE35-KTT-B	1,3	35	135	10	11,5	51,3	
RFE40	GG.FE08	GE40-KRR-B	1,72	40	145	11,5	11,5	56,5	
TFE40	GG.FE08	GE40-KTT-B	1,72	40	145	11,5	11,5	56,5	
RFE45	GG.FE09	GE45-KRR-B	2,06	45	155	12	14	56,5	
RFE50-N¹⁾	GG.FE10-N	GE50-KRR-B	2,48	50	165	13	14	62,8	
TFE50-N¹⁾	GG.FE10-N	GE50-KTT-B	2,48	50	165	13	14	62,8	
RFE60	GG.FE12	GE60-KRR-B	3,99	60	195	16	14	77,9	
TFE60	GG.FE12	GE60-KTT-B	3,99	60	195	16	14	77,9	

¹⁾ Closing plug KASK10 to be ordered separately.

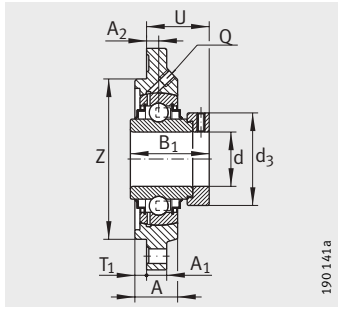

RFE

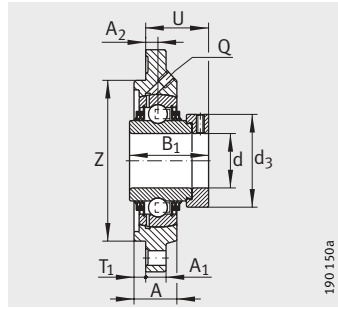

TFE

								Basic load ratings	
J	A ₂	Q	d ₃ max.	A	T ₁	U	Z h8	dyn. C _r N	stat. C _{0r} N
92	9,5	R _p 1/8	37,5	22	3	36,4	75	14 000	7 800
92	9,5	R _p 1/8	37,5	22	3	36,4	75	14 000	7 800
105	10,5	R _p 1/8	44	22,5	3	40,6	85	19 500	11 300
105	10,5	R _p 1/8	44	22,5	3	40,6	85	19 500	11 300
110	9	R _p 1/8	51	22,5	4	41,3	90	25 500	15 300
110	9	R _p 1/8	51	22,5	4	41,3	90	25 500	15 300
120	11,5	R _p 1/8	58	26	4	46,4	100	32 500	19 800
120	11,5	R _p 1/8	58	26	4	46,4	100	32 500	19 800
130	11,5	R _p 1/8	63	26,5	4	46,4	105	32 500	20 400
136	12,5	R _p 1/8	69	27,5	4	50,6	115	35 000	23 200
136	12,5	R _p 1/8	69	27,5	4	50,6	115	35 000	23 200
165	17	R _p 1/8	84	33	4	63,8	140	52 000	36 000
165	17	R _p 1/8	84	33	4	63,8	140	52 000	36 000



Four-bolt flanged housing units

Cast iron housings with
double row angular contact ball bearing

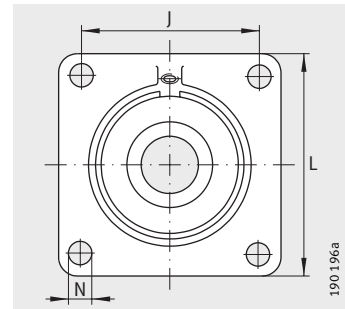

PCCJ

Dimension table · Dimensions in mm								
Designation			Mass m ≈kg	Dimensions				
Unit	Housing	Double row angular contact ball bearing		L	A ₁	N	B	J
PCCJ25	GG.CCJ05	G5205-2RS-N	0,79	95	12	11,5	30	70
PCCJ30	GG.CCJ06	G5206-2RS-N	1,12	108	12	11,5	34	82,5
PCCJ35	GG.CCJ07	G5207-2RS-N	1,48	118	14	14	36	92
PCCJ40	GG.CCJ08	G5208-2RS-N	1,8	130	14	14	38	101,5

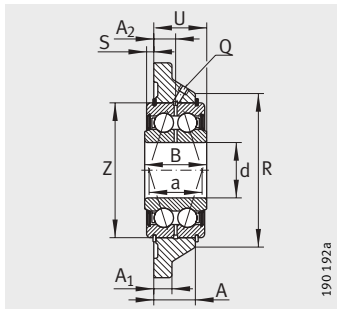

PCCJ

								Basic load ratings	
A ₂	Q	R max.	S	A	U	Z h8	a	dyn. C _r N	stat. C _{0r} N
11,7	M6	64	2,4	22,1	26,7	52	24	21 600	14 900
13	M6	76	3,2	24	29,7	62	28,9	30 000	21 400
14	M6	88	3	26	31,7	72	33,8	39 500	29 000
15	M6	98	3,2	28	33,7	80	38,8	50 000	38 000



Take-up housing units

Cast iron housings

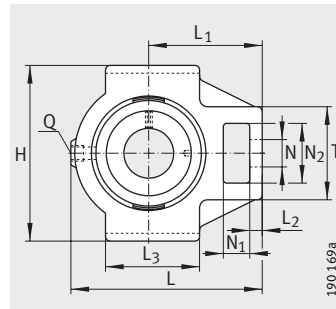

PTUE, RTUE, TTUE, PTUEY, RTUEY

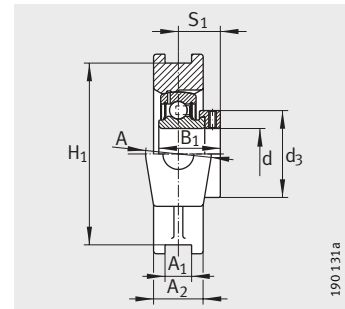

PTUE

Dimension table · Dimensions in mm										
Designation			Mass m ≈kg	Dimensions						
Unit	Housing	Radial insert ball bearing		d	A	A ₁ H13	A ₂	L	L ₁	L ₂
PTUE20	GG.TUE04	GRAE20-NPP-B	0,83	20	37	12	25	94,5	60	9
RTUE20	GG.TUE04	GE20-KRR-B	0,87	20	37	12	25	94,5	60	9
TTUE20	GG.TUE04	GE20-KTT-B	0,87	20	37	12	25	94,5	60	9
PTUEY20	GG.TUE04	GAY20-NPP-B	0,8	20	37	12	25	94,5	60	9
RTUEY20	GG.TUE04	GYE20-KRR-B	0,84	20	37	12	25	94,5	60	9
PTUE25	GG.TUE05	GRAE25-NPP-B	0,85	25	37	12	25	98,5	62	10
RTUE25	GG.TUE05	GE25-KRR-B	0,91	25	37	12	25	98,5	62	10
TTUE25	GG.TUE05	GE25-KTT-B	0,91	25	37	12	25	98,5	62	10
PTUEY25	GG.TUE05	GAY25-NPP-B	0,82	25	37	12	25	98,5	62	10
RTUEY25	GG.TUE05	GYE25-KRR-B	0,86	25	37	12	25	98,5	62	10
PTUE30	GG.TUE06	GRAE30-NPP-B	1,17	30	37	12	25	114,5	70	10
RTUE30	GG.TUE06	GE30-KRR-B	1,24	30	37	12	25	114,5	70	10
TTUE30	GG.TUE06	GE30-KTT-B	1,25	30	37	12	25	114,5	70	10
PTUEY30	GG.TUE06	GAY30-NPP-B	1,11	30	37	12	25	114,5	70	10
RTUEY30	GG.TUE06	GYE30-KRR-B	1,19	30	37	12	25	114,5	70	10
PTUE35	GG.TUE07	GRAE35-NPP-B	1,73	35	40	12	30	131,5	80	13
RTUE35	GG.TUE07	GE35-KRR-B	1,8	35	40	12	30	131,5	80	13
TTUE35	GG.TUE07	GE35-KTT-B	1,81	35	40	12	30	131,5	80	13
PTUEY35	GG.TUE07	GAY35-NPP-B	1,64	35	40	12	30	131,5	80	13
RTUEY35	GG.TUE07	GYE35-KRR-B	1,74	35	40	12	30	131,5	80	13
PTUE40	GG.TUE08	GRAE40-NPP-B	2,4	40	50	16	35	141	88	16
RTUE40	GG.TUE08	GE40-KRR-B	2,52	40	50	16	35	141	88	16
TTUE40	GG.TUE08	GE40-KTT-B	2,55	40	50	16	35	141	88	16
RTUEY40	GG.TUE08	GYE40-KRR-B	2,43	40	50	16	35	141	88	16
PTUE45	GG.TUE09	GRAE45-NPP-B	2,49	45	50	16	35	141	88	16
RTUE45	GG.TUE09	GE45-KRR-B	2,61	45	50	16	35	141	88	16
TTUE45	GG.TUE09	GE45-KTT-B	2,66	45	50	16	35	141	88	16
PTUE50	GG.TUE10	GRAE50-NPP-B	2,42	50	50	16	35	148	90	16
RTUE50	GG.TUE10	GE50-KRR-B	2,65	50	50	16	35	148	90	16
TTUE50	GG.TUE10	GE50-KTT-B	2,71	50	50	16	35	148	90	16
PTUEY50	GG.TUE10	GAY50-NPP-B	2,27	50	50	16	35	148	90	16
RTUEY50	GG.TUE10	GYE50-KRR-B	2,45	50	50	16	35	148	90	16
PTUE55	GG.TUE11	GRAE55-NPP-B	3,99	55	60	22	42	169	104	17
RTUE55	GG.TUE11	GE55-KRR-B	4,6	55	60	22	42	169	104	17
TTUE55	GG.TUE11	GE55-KTT-B	4,72	55	60	22	42	169	104	17

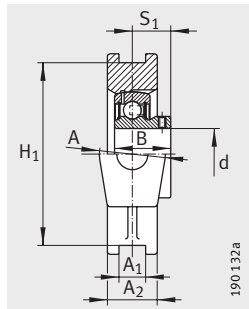

PTUEY

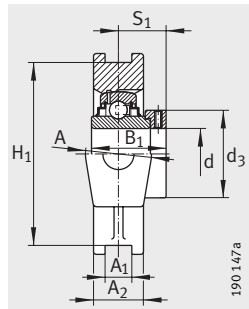

RTUE

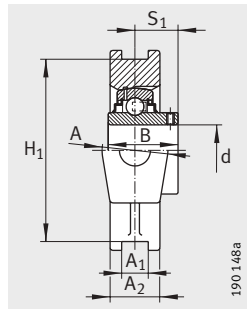

RTUEY

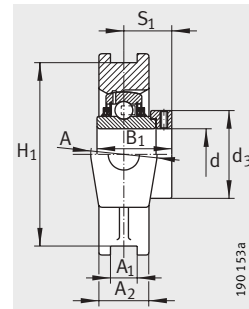

TTUE

													Basic load ratings	
N	N ₁	N ₂	B	B ₁	H	H ₁	S ₁	Q	T	L ₃	d ₃	dyn. C _r	stat. C _{0r}	
						±0,15					max.	N	N	
19	18	32	-	31	90	76	23,5	R _p 1/8	51	50	33	12 800	6 600	
19	18	32	-	43,7	90	76	26,6	R _p 1/8	51	50	33	12 800	6 600	
19	18	32	-	43,7	90	76	26,6	R _p 1/8	51	50	33	12 800	6 600	
19	18	32	25	-	90	76	18	R _p 1/8	51	50	-	12 800	6 600	
19	18	32	31	-	90	76	18,3	R _p 1/8	51	50	-	12 800	6 600	
19	18	32	-	31	90	76	23,5	R _p 1/8	51	50	37,5	14 000	7 800	
19	18	32	-	44,5	90	76	26,9	R _p 1/8	51	50	37,5	14 000	7 800	
19	18	32	-	44,5	90	76	26,9	R _p 1/8	51	50	37,5	14 000	7 800	
19	18	32	27	-	90	76	19,5	R _p 1/8	51	50	-	14 000	7 800	
19	18	32	34,1	-	90	76	19,8	R _p 1/8	51	50	-	14 000	7 800	
22	18	36,5	-	35,8	102	89	26,7	R _p 1/8	56	57	44	19 500	11 300	
22	18	36,5	-	48,5	102	89	30,1	R _p 1/8	56	57	44	19 500	11 300	
22	18	36,5	-	48,5	102	89	30,1	R _p 1/8	56	57	44	19 500	11 300	
22	18	36,5	30	-	102	89	21	R _p 1/8	56	57	-	19 500	11 300	
22	18	36,5	38,1	-	102	89	22,2	R _p 1/8	56	57	-	19 500	11 300	
22	18	36,5	-	39	102	89	29,4	R _p 1/8	64	63	51	25 500	15 300	
22	18	36,5	-	51,3	102	89	32,3	R _p 1/8	64	63	51	25 500	15 300	
22	18	36,5	-	51,3	102	89	32,3	R _p 1/8	64	63	51	25 500	15 300	
22	18	36,5	35	-	102	89	25,5	R _p 1/8	64	63	-	25 500	15 300	
22	18	36,5	42,9	-	102	89	25,4	R _p 1/8	64	63	-	25 500	15 300	
29	20	49	-	43,8	115	102	32,7	R _p 1/8	82	82	58	32 500	19 800	
29	20	49	-	56,5	115	102	34,9	R _p 1/8	82	82	58	32 500	19 800	
29	20	49	-	56,5	115	102	34,9	R _p 1/8	82	82	58	32 500	19 800	
29	20	49	49,2	-	115	102	30,2	R _p 1/8	82	82	-	32 500	19 800	
29	20	49	-	43,8	115	102	32,7	R _p 1/8	82	82	63	32 500	20 400	
29	20	49	-	56,5	115	102	34,9	R _p 1/8	82	82	63	32 500	20 400	
29	20	49	-	56,5	115	102	34,9	R _p 1/8	82	82	63	32 500	20 400	
29	20	49	-	43,8	115	102	32,7	R _p 1/8	83	85	69	35 000	23 200	
29	20	49	-	62,8	115	102	38,1	R _p 1/8	83	85	69	35 000	23 200	
29	20	49	-	62,8	115	102	38,1	R _p 1/8	83	85	69	35 000	23 200	
29	20	49	43	-	115	102	32	R _p 1/8	83	85	-	35 000	23 200	
29	20	49	51,6	-	115	102	32,6	R _p 1/8	83	85	-	35 000	23 200	
35	26	63,5	-	48,4	145	130	36,4	R _p 1/8	102	95	76	43 500	29 000	
35	26	63,5	-	71,4	145	130	43,6	R _p 1/8	102	95	76	43 500	29 000	
35	26	63,5	-	71,4	145	130	43,6	R _p 1/8	102	95	76	43 500	29 000	



Take-up housing units

Cast iron housings

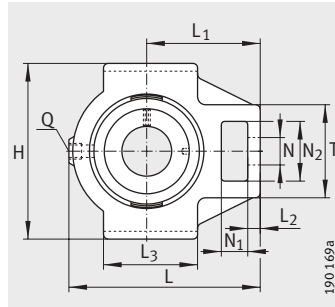

PTUE, RTUE, TTUE, RTUEO, PTUEY, RTUEY

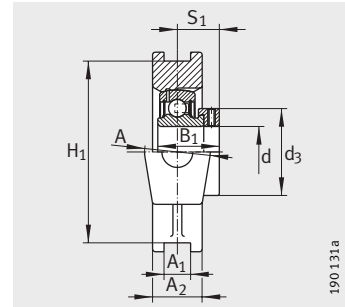

PTUE

Dimension table (continued) · Dimensions in mm										
Designation			Mass m ≈ kg	Dimensions						
Unit	Housing	Radial insert ball bearing		d	A	A ₁ H13	A ₂	L	L ₁	L ₂
PTUE60	GG.TUE12	GRAE60-NPP-B	4,21	60	60	22	44	186	118	19
RTUE60	GG.TUE12	GE60-KRR-B	4,84	60	60	22	44	186	118	19
TTUE60	GG.TUE12	GE60-KTT-B	4,96	60	60	22	44	186	118	19
PTUEY60	GG.TUE12	GAY60-NPP-B	3,97	60	60	22	44	186	118	19
RTUEY60	GG.TUE12	GYE60-KRR-B	4,22	60	60	22	44	186	118	19
RTUE65	GG.TUE13/14	GE65-214-KRR-B	7,46	65	70	25	50	214	135	20
TTUE65	GG.TUE13/14	GE65-214-KTT-B	7,54	65	70	25	50	214	135	20
RTUEY65	GG.TUE13/14	GYE65-214-KRR-B	7	65	70	25	50	214	135	20
RTUE70	GG.TUE13/14	GE70-KRR-B	7,2	70	70	25	50	214	135	20
TTUE70	GG.TUE13/14	GE70-KTT-B	7,28	70	70	25	50	214	135	20
RTUEY70	GG.TUE13/14	GYE70-KRR-B	6,7	70	70	25	50	214	135	20
RTUE75	GG.TUE15	GE75-KRR-B	7,05	75	70	25	50	214	135	20
TTUE75	GG.TUE15	GE75-KTT-B	7,13	75	70	25	50	214	135	20
RTUEY75	GG.TUE15	GYE75-KRR-B	6,59	75	70	25	50	214	135	20
RTUE80	GG.TUE16	GE80-KRR-B	8,4	80	70	28	50	230	140	20
TTUE80	GG.TUE16	GE80-KTT-B	8,46	80	70	28	50	230	140	20
RTUEO80	GG.TUEO16	GNE80-KRR-B	17,25	80	102	30	60	282	174	28
RTUEY80	GG.TUE16	GYE80-KRR-B	8,38	80	70	28	50	230	140	20
RTUE90	GG.TUE18	GE90-KRR-B	11,57	90	80	28	55	275	170	30
RTUEO90	GG.TUEO18	GNE90-KRR-B	22,9	90	110	32	66	312	192	30
RTUE100	GG.TUE20	GE100-KRR-B	14,55	100	90	28	60	295	180	30
RTUE120	GG.TUE24	GE120-KRR-B	22,43	120	100	32	70	345	210	35

1) Tolerance ${}^0_{-0,6}$.

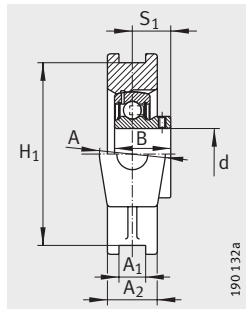

PTUEY

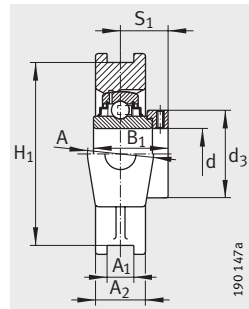

RTUE, RTUEO

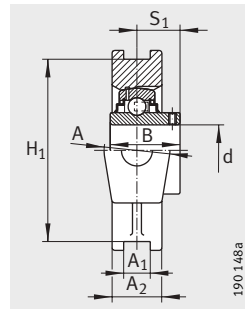

RTUEY

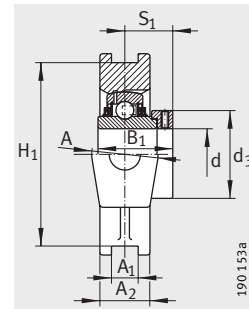

TTUE

												Basic load ratings	
N	N ₁	N ₂	B	B ₁	H	H ₁	S ₁	Q	T	L ₃	d ₃ max.	dyn. C _r N	stat. C _{0r} N
35	32	63,5	–	53,1	146	130±0,15	39,6	R _p 1/8	102	100	84	52 000	36 000
35	32	63,5	–	77,9	146	130±0,15	46,8	R _p 1/8	102	100	84	52 000	36 000
35	32	63,5	–	77,9	146	130±0,15	46,8	R _p 1/8	102	100	84	52 000	36 000
35	32	63,5	47	–	146	130±0,15	34	R _p 1/8	102	100	–	52 000	36 000
35	32	63,5	65,1	–	146	130±0,15	39,7	R _p 1/8	102	100	–	52 000	36 000
41	35	70	–	66	166	151±0,25	44,6	R _p 1/8	110	120	96	62 000	44 000
41	35	70	–	66	166	151±0,25	44,6	R _p 1/8	110	120	96	62 000	44 000
41	35	70	74,6	–	166	151±0,25	44,4	R _p 1/8	110	120	–	62 000	44 000
41	35	70	–	66	166	151±0,25	44,6	R _p 1/8	110	120	96	62 000	44 000
41	35	70	–	66	166	151±0,25	44,6	R _p 1/8	110	120	96	62 000	44 000
41	35	70	74,6	–	166	151±0,25	44,4	R _p 1/8	110	120	–	62 000	44 000
41	35	70	–	67	166	151±0,25	45,6	R _p 1/8	110	120	100	62 000	44 500
41	35	70	–	67	166	151±0,25	45,6	R _p 1/8	110	120	100	62 000	44 500
41	35	70	77,8	–	166	151±0,25	44,5	R _p 1/8	110	120	–	62 000	44 500
41	35	70	–	70,7	184	165±0,25	47,6	R _p 1/8	110	120	108	72 000	54 000
41	35	70	–	70,7	184	165±0,25	47,6	R _p 1/8	110	120	108	72 000	54 000
53	42	98	–	93,7	230	204 ¹⁾	59,7	R _p 1/8	150	150	118	123 000	87 000
41	35	70	82,6	–	184	165±0,25	49,3	R _p 1/8	110	120	–	72 000	54 000
47	40	80	–	69,5	215	190±0,25	46,5	R _p 1/8	130	140	118	96 000	72 000
57	46	106	–	101	255	228 ¹⁾	65,5	R _p 1/8	160	165	132	143 000	107 000
47	40	80	–	75	240	215±0,25	49,5	R _p 1/8	130	160	132	122 000	93 000
55	45	95	–	81	285	255±0,25	52,5	R _p 1/8	150	190	152	155 000	131 000



Take-up housing units

Cast iron housings

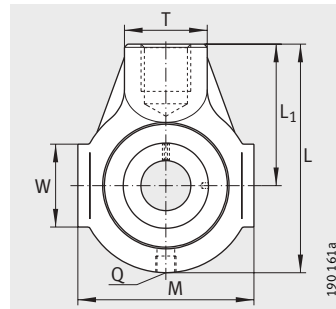

PHE, PHEY, RHE, THE

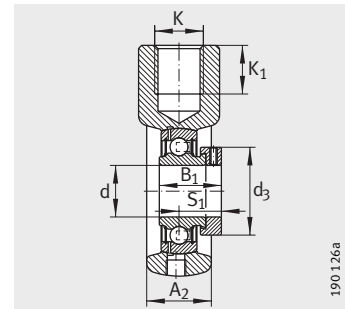

PHE

Dimension table · Dimensions in mm									
Designation			Mass m ≈ kg	Dimensions					
Unit	Housing	Radial insert ball bearing		d	L	A ₂	L ₁	K	K ₁
PHE20	GG.HE04	GRAE20-NPP-B	0,54	20	91	25	58	M16	21
PHEY20	GG.HE04	GAY20-NPP-B	0,51	20	91	25	58	M16	21
RHE20	GG.HE04	GE20-KRR-B	0,58	20	91	25	58	M16	21
PHE25	GG.HE05	GRAE25-NPP-B	0,71	25	99	28	64	M20	22
PHEY25	GG.HE05	GAY25-NPP-B	0,68	25	99	28	64	M20	22
RHE20	GG.HE05	GE25-KRR-B	0,77	25	99	28	64	M20	22
THE25	GG.HE05	GE25-KTT-B	0,77	25	99	28	64	M20	22
PHE30	GG.HE06	GRAE30-NPP-B	1,09	30	114	32	72	M24	24
PHEY30	GG.HE06	GAY30-NPP-B	1,03	30	114	32	72	M24	24
RHE30	GG.HE06	GE30-KRR-B	1,16	30	114	32	72	M24	24
THE30	GG.HE06	GE30-KTT-B	1,17	30	114	32	72	M24	24
PHE35	GG.HE07	GRAE35-NPP-B	1,32	35	122	32	76	M24	24
PHEY35	GG.HE07	GAY35-NPP-B	1,23	35	122	32	76	M24	24
RHE35	GG.HE07	GE35-KRR-B	1,39	35	122	32	76	M24	24
THE35	GG.HE07	GE35-KTT-B	1,4	35	122	32	76	M24	24
PHE40	GG.HE08	GRAE40-NPP-B	1,65	40	135	36	85	M24	24
PHEY40	GG.HE08	GAY40-NPP-B	1,54	40	135	36	85	M24	24
RHE40	GG.HE08	GE40-KRR-B	1,77	40	135	36	85	M24	24
THE40	GG.HE08	GE40-KTT-B	1,8	40	135	36	85	M24	24
PHE45	GG.HE09	GRAE45-NPP-B	1,89	45	145	40	90	M24	24
PHEY45	GG.HE09	GAY45-NPP-B	1,75	45	145	40	90	M24	24
RHE45	GG.HE09	GE45-KRR-B	2,01	45	145	40	90	M24	24
THE45	GG.HE09	GE45-KTT-B	2,06	45	145	40	90	M24	24
PHE50	GG.HE10	GRAE50-NPP-B	1,92	50	145	40	90	M24	24
RHE50	GG.HE10	GE50-KRR-B	2,15	50	145	40	90	M24	24
THE50	GG.HE10	GE50-KTT-B	2,21	50	145	40	90	M24	24

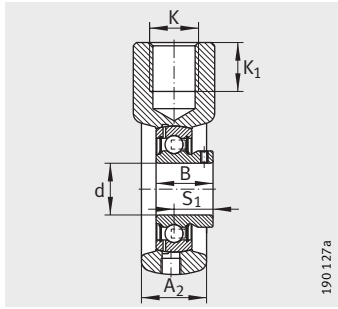

PHEY

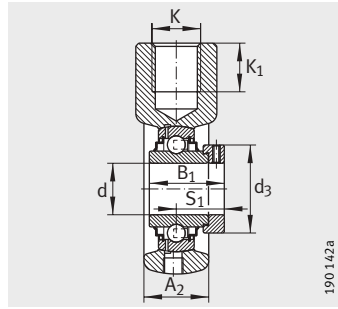

RHE

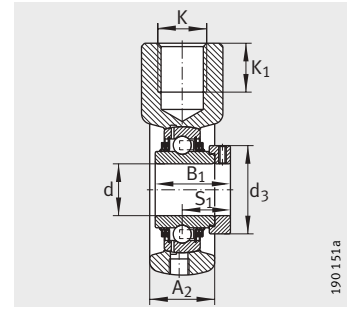

THE

								Basic load ratings	
B	B ₁	M	S ₁	Q	d ₃ max.	T	W	dyn. C _r N	stat. C _{0r} N
-	31	65	23,5	R _p 1/8	33	30	38	12 800	6 600
25	-	65	18	R _p 1/8	-	30	38	12 800	6 600
-	43,7	65	26,6	R _p 1/8	33	30	38	12 800	6 600
-	31	70	23,5	R _p 1/8	37,5	35	38	14 000	7 800
27	-	70	19,5	R _p 1/8	-	35	38	14 000	7 800
-	44,5	70	26,9	R _p 1/8	37,5	35	38	14 000	7 800
-	44,5	70	26,9	R _p 1/8	37,5	35	38	14 000	7 800
-	35,8	85	26,7	R _p 1/8	44	40	40	19 500	11 300
30	-	85	21	R _p 1/8	-	40	40	19 500	11 300
-	48,5	85	30,1	R _p 1/8	44	40	40	19 500	11 300
-	48,5	85	30,1	R _p 1/8	44	40	40	19 500	11 300
-	39	90	29,4	R _p 1/8	51	40	49	25 500	15 300
35	-	90	25,5	R _p 1/8	-	40	49	25 500	15 300
-	51,3	90	32,3	R _p 1/8	51	40	49	25 500	15 300
-	51,3	90	32,3	R _p 1/8	51	40	49	25 500	15 300
-	43,8	100	32,7	R _p 1/8	58	40	45	32 500	19 800
39,5	-	100	29	R _p 1/8	-	40	45	32 500	19 800
-	56,5	100	34,9	R _p 1/8	58	40	45	32 500	19 800
-	56,5	100	34,9	R _p 1/8	58	40	45	32 500	19 800
-	43,7	110	32,7	R _p 1/8	63	40	45	32 500	20 400
41,5	-	110	30,5	R _p 1/8	-	40	45	32 500	20 400
-	56,5	110	34,9	R _p 1/8	63	40	45	32 500	20 400
-	56,5	110	34,9	R _p 1/8	63	40	45	32 500	20 400
-	43,8	110	32,7	R _p 1/8	69	40	46	35 000	23 200
-	62,8	110	38,1	R _p 1/8	69	40	46	35 000	23 200
-	62,8	110	38,1	R _p 1/8	69	40	46	35 000	23 200



Take-up housing units

Cast iron/sheet steel housings

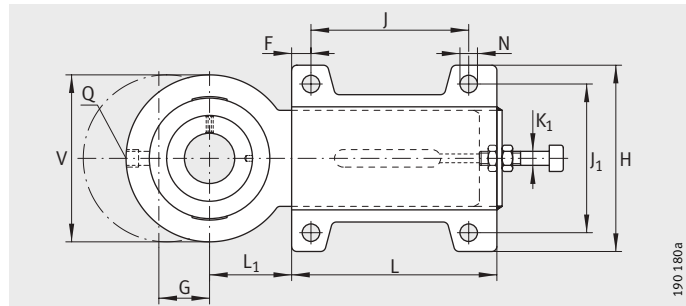

PHUSE

Dimension table · Dimensions in mm											
Designation		Mass m ≈kg	Dimensions								
Unit	Radial insert ball bearing		d	L	A ₂	S	F	G	L ₁	N	K ₁
PHUSE25	GRAE25-NPP-B	2,07	25	187	22	4	20	65	50	11,5	M12
PHUSE30	GRAE30-NPP-B	2,22	30	187	22	4	20	65	50	11,5	M12
PHUSE35	GRAE35-NPP-B	2,46	35	187	22	4	20	65	50	11,5	M12
PHUSE40	GRAE40-NPP-B	4,89	40	256	30	4	20	80	60	14	M16
PHUSE50-N ¹⁾	GRAE50-NPP-B	5,25	50	256	30	4	20	80	60	14	M16

¹⁾ End cap KASK10 to be ordered separately.

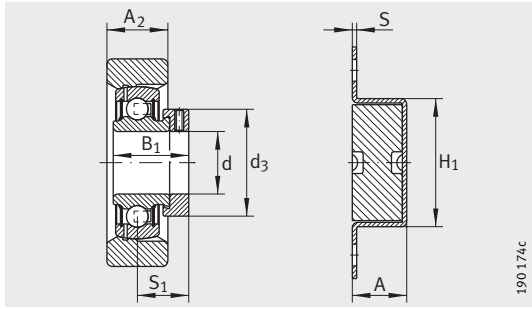

PHUSE

										Load carrying capacity of housing C_{0rG} N	Basic load ratings	
B_1	J	J_1	S_1	Q	d_3 max.	A	V	H	H_1		dyn. C_r N	stat. C_{0r} N
31	140	80	23,5	$R_p 1/8$	37,5	28	78	103	52	7 800	14 000	7 800
35,8	140	80	26,7	$R_p 1/8$	44	28	88	103	52	11 300	19 500	11 300
39	140	80	29,4	$R_p 1/8$	51	28	98	103	52	15 300	25 500	15 300
43,8	180	100	32,7	$R_p 1/8$	58	36	108	130	60	19 800	32 500	19 800
43,8	180	100	32,7	$R_p 1/8$	69	36	120	130	60	23 200	35 000	23 200



Take-up housing units

Cast iron housings
Sheet steel housings

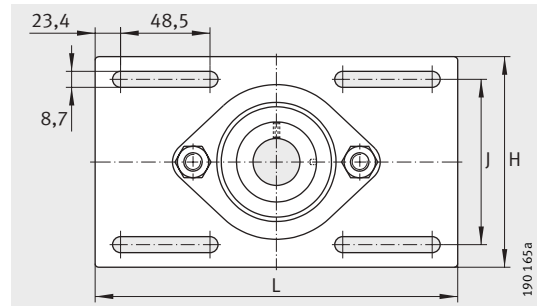

MSTU

Dimension table · Dimensions in mm										
Designation			Mass m ≈kg	Dimensions						
Unit	Housing	Radial insert ball bearing		d	H	A ₁	L	S	B	N ₁
PSFT20	GG.SFT04	GRAE20-NPP-B	0,41	20	–	10	112	–	11,5	30
MSTU25	GEH52-MSTU	RAE25-NPP-B	0,58	25	104,8	–	203,2	2	–	–
PSFT25	GG.SFT05	GRAE25-NPP-B	0,52	25	–	11	124	–	11,5	37,5
MSTU30	GEH62-MSTU	RAE30-NPP-B	0,84	30	114,3	–	203,2	2,5	–	–
PSFT30	GG.SFT06	GRAE30-NPP-B	0,77	30	–	12	142	–	11,5	40
PSFT35	GG.SFT07	GRAE35-NPP-B	1,1	35	–	12,5	155	–	14	45

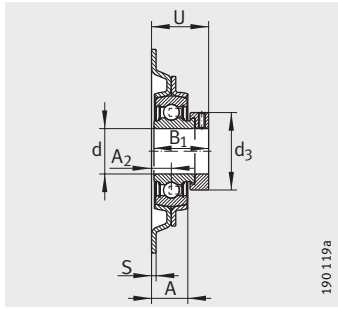

MSTU

190 119a

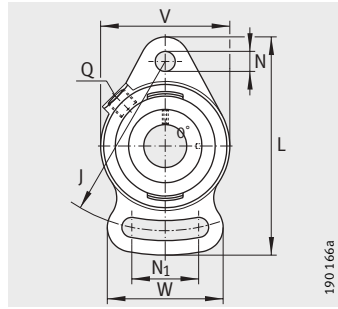

PSFT

190 166a

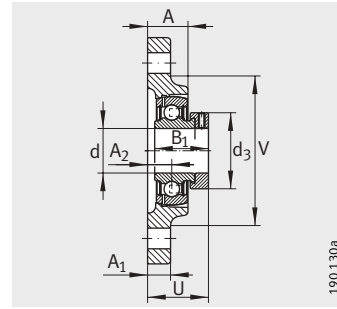

PSFT

190 130a

									Load carrying capacity of housing C_{0rG} N	Basic load ratings	
B_1	J	A_2	Q	d_3 max.	A	U	V	W		dyn. C_r N	stat. C_{0r} N
31	90	10,5	$R_p 1/8$	33	18	34	61	52	–	12 800	6 600
31	80,2	10,3	–	37,5	19	33,8	–	–	3 900	14 000	7 800
31	99	12,5	$R_p 1/8$	37,5	20	36	70	63	–	14 000	7 800
35,8	89,2	12,1	–	44	21,1	37,8	–	–	3 900	19 500	11 300
35,8	117	13	$R_p 1/8$	44	22	39,7	80	65	–	19 500	11 300
39	128	15	$R_p 1/8$	51	25	44,5	90	75	–	25 500	15 300



Plummer block housing units

Sheet steel housings

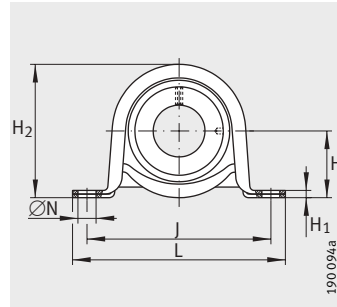

PB, PBY, RPB

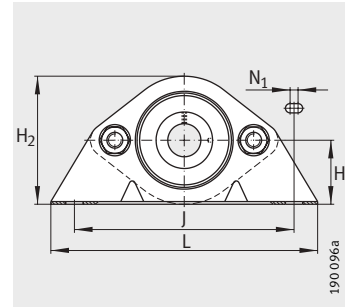

PBS

Dimension table · Dimensions in mm										
Unit	Housing	Rubber interliner	Radial insert ball bearing	Mass m ≈kg	Dimensions					
					d	H	A	A ₁	H ₁	H ₂
PB12	GEH40-BT	–	RAE12-NPP-B	0,17	12	22,2	25,4	18,4	2,6	43,2
PBY12	GEH40-BT	–	AY12-NPP-B	0,15	12	22,2	25,4	18,4	2,6	43,2
RPB12	GEH47-BT	RABR40/47	RAE12-NPP-B	0,23	12	25,4	31,8	22,3	3,3	50,1
PBS12	GEH40-PBS	–	RAE12-NPP-B	0,32	12	30,2	32,5	14,2	2,6	59,6
PB15	GEH40-BT	–	RAE15-NPP-B	0,17	15	22,2	25,4	18,4	2,6	43,2
PBY15	GEH40-BT	–	AY15-NPP-B	0,15	15	22,2	25,4	18,4	2,6	43,2
RPB15	GEH47-BT	RABR40/47	RAE15-NPP-B	0,23	15	25,4	31,8	22,3	3,3	50,1
PBS15	GEH40-PBS	–	RAE15-NPP-B	0,32	15	30,2	32,5	14,2	2,6	59,6
PB17	GEH40-BT	–	RAE17-NPP-B	0,17	17	22,2	25,4	18,4	2,6	43,2
PBY17	GEH40-BT	–	AY17-NPP-B	0,15	17	22,2	25,4	18,4	2,6	43,2
RPB17	GEH47-BT	RABR40/47	RAE17-NPP-B	0,23	17	25,4	31,8	22,3	3,3	50,1
PBS17	GEH40-PBS	–	RAE17-NPP-B	0,32	17	30,2	32,5	14,2	2,6	59,6
PB20	GEH47-BT	–	RAE20-NPP-B	0,27	20	25,4	31,8	22,3	3,3	50,1
PBY20	GEH47-BT	–	AY20-NPP-B	0,22	20	25,4	31,8	22,3	3,3	50,1
RPB20	GEH52-BT	RABR47/52	RAE20-NPP-B	0,28	20	28,6	31,8	23,5	4	56,5
PBS20	GEH40-PBS	–	RAE20-NPP-B	0,45	20	33,6	33	15,8	3	66,8
PB25	GEH52-BT	–	RAE25-NPP-B	0,3	25	28,6	31,8	23,5	4	56,5
PBY25	GEH52-BT	–	AY25-NPP-B	0,26	25	28,6	31,8	23,5	4	56,5
RPB25	GEH62-BT	RABR52/62	RAE25-NPP-B	0,38	25	33,3	38	26,5	4	66,1
PBS25	GEH52-BT	–	RAE25-NPP-B	0,49	25	36,5	34,1	17,4	3,4	72
PB30	GEH62-BT	–	RAE30-NPP-B	0,5	30	33,3	38	26,5	4	66,1
PBY30	GEH62-BT	–	AY30-NPP-B	0,4	30	33,3	38	26,5	4	66,1
RPB30	GEH62-BT	RABR55/62	RAE30-NPP-B	0,45	30	33,3	38	26,5	4	66,1
PBS30	GEH62-PBS	–	RAE30-NPP-B	0,79	30	42,9	38,9	17,4	3,4	85
PBS35	GEH72-PBS	–	RAE35-NPP-B	1,05	35	47,6	46,1	22,2	4	94,4
PBS40	GEH80-PBS	–	RAE40-NPP-B	1,33	40	55	53,5	23	4	106

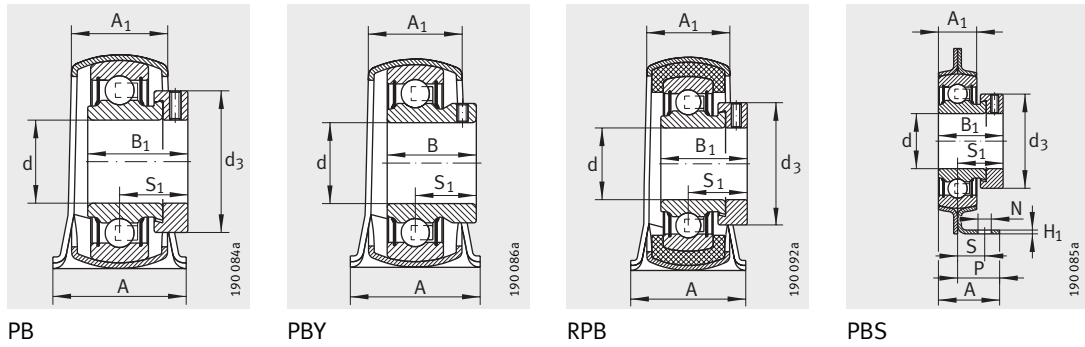

N	N ₁	B	B ₁	J	S ₁	P	S	d ₃ max.	L	Load carrying capacity of housing C _{0rG} N	Basic load ratings	
											dyn. C _r N	stat. C _{0r} N
9,5	-	22	28,6	68	22,1	-	-	28	85,7	1 350	9 800	4 750
9,5	-	-	-	68	16	-	-	-	85,7	1 350	9 800	4 750
9,5	-	-	28,6	76	22,1	-	-	28	98,7	900	9 800	4 750
10,5	5,6	-	28,6	92	22,1	25,4	15	28	123,8	2 700	9 800	4 750
9,5	-	22	28,6	68	22,1	-	-	28	85,7	1 350	9 800	4 750
9,5	-	-	-	68	16	-	-	-	85,7	1 350	9 800	4 750
9,5	-	-	28,6	76	22,1	-	-	28	98,4	900	9 800	4 750
10,5	5,6	-	28,6	92	22,1	25,4	15	28	123,8	2 700	9 800	4 750
9,5	-	22	28,6	68	22,1	-	-	28	85,7	1 350	9 800	4 750
9,5	-	-	-	68	16	-	-	-	85,7	1 350	9 800	4 750
9,5	-	-	28,6	76	22,1	-	-	28	98,4	900	9 800	4 750
10,5	5,6	-	28,6	92	22,1	25,4	15	28	123,8	2 700	9 800	4 750
9,5	-	25	31	76	23,5	-	-	33	98,4	1 600	12 800	6 600
9,5	-	-	-	76	18	-	-	-	98,4	1 600	12 800	6 600
11,5	-	-	31	86	23,5	-	-	33	108	1 100	12 800	6 600
10,5	5,6	-	31	97	23,5	25,4	15	33	127	3 200	12 800	6 600
11,5	-	27	31	86	23,5	-	-	37,5	108	1 800	14 000	7 800
11,5	-	-	-	86	19,5	-	-	-	108	1 800	14 000	7 800
11,5	-	-	31	95	23,5	-	-	37,5	117,5	1 400	14 000	7 800
10,5	9,5	-	31	95,5	23,5	25,4	14,3	37,5	133,5	3 600	14 000	7 800
11,5	-	30	35,8	95	26,7	-	-	44	117,5	2 700	19 500	11 300
11,5	-	-	-	95	21	-	-	-	117,5	2 700	19 500	11 300
11,5	-	-	26,5	95	20	-	-	42,5	117,5	1 400	13 200	8 300
13,5	8	-	35,8	119	26,7	30,2	16	44	159	3 600	19 500	11 300
13,5	8	-	39	127	29,4	35	20,7	51	165	4 100	25 500	15 300
13,5	8	-	43,8	136,5	32,7	40	25	58	180	4 500	32 500	19 800



Two-bolt flanged housing units

Sheet steel housings

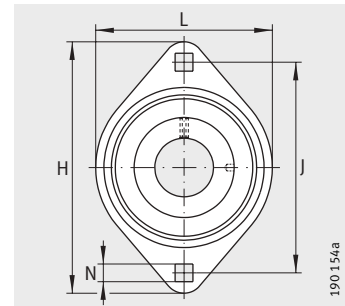

RAT, RATY, RALT, PCSLT

Dimension table · Dimensions in mm						
Designation			Mass m ≈kg	Dimensions		
Unit	Housing	Radial insert ball bearing		d	L	H
RAT12	FLAN40-MST (2 parts)	RAE12-NPP-B	0,19	12	58,7	81
RATY12	FLAN40-MST (2 parts)	AY12-NPP-B	0,14	12	58,7	81
RAT15	FLAN40-MST (2 parts)	RAE15-NPP-B	0,19	15	58,7	81
RATY15	FLAN40-MST (2 parts)	AY15-NPP-B	0,13	15	58,7	81
RAT17	FLAN40-MST (2 parts)	RAE17-NPP-B	0,19	17	58,7	81
RATY17	FLAN40-MST (2 parts)	AY17-NPP-B	0,12	17	58,7	81
RALT20-FA125.8	FLAN42-LST-FA125 (2 parts)	RALE20-NPP-B	0,21	20	58,7	81
PCSLT20	FLAN42-CSLT-FA125/FLAN42-CST-FA125 (1 part each)	RALE20-NPP-B	0,22	20	66	90,5
RAT20	FLAN47-MST (2 parts)	RAE20-NPP-B	0,27	20	66	90,5
RATY20	FLAN47-MST (2 parts)	AY20-NPP-B	0,22	20	66	90,5
RALT25	FLAN47-LST (2 parts)	RALE25-NPP-B	0,22	25	71	95,2
PCSLT25	FLAN47-CSLT-FA125/FLAN47-CST-FA125 (1 part each)	RALE25-NPP-B	0,25	25	71	95,2
RAT25	FLAN52-MST (2 parts)	RAE25-NPP-B	0,34	25	71	95,2
RATY25	FLAN52-MST (2 parts)	AY25-NPP-B	0,26	25	71	95,2
PCSLT30	FLAN55-CSLT-FA125/FLAN55-CST-FA125 (1 part each)	RALE30-NPP-B	0,3	30	84	112,5
RAT30	FLAN62-MST (2 parts)	RAE30-NPP-B	0,49	30	84	112,7
RATY30	FLAN62-MST (2 parts)	AY30-NPP-B	0,41	30	84	112,7
RAT35	FLAN72-MST (2 parts)	RAE35-NPP-B	0,72	35	93,7	123
RATY35	FLAN72-MST (2 parts)	GAY35-NPP-B	0,56	35	93,7	123
RAT40	FLAN80-MST (2 parts)	RAE40-NPP-B	0,98	40	100	151
RATY40	FLAN80-MST (2 parts)	GAY40-NPP-B	0,85	40	100	151

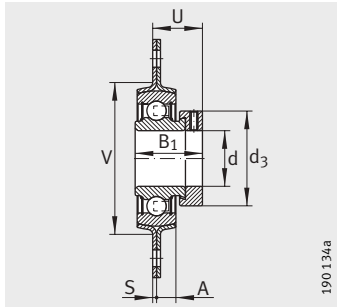

RAT, RALT

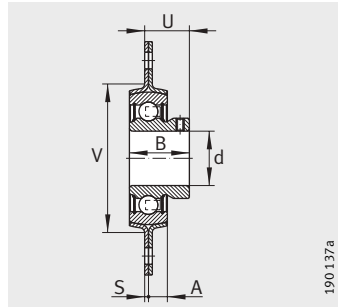

RATY

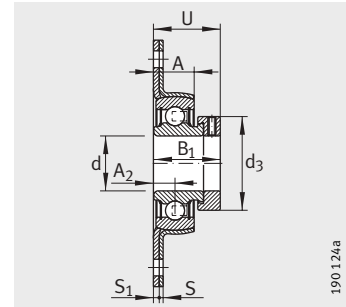

PCSLT

											Load carrying capacity of housing C_{0rG}	Basic load ratings	
S	S ₁	N	B	B ₁	J	A ₂	d ₃ max.	A	U	V		N	dyn. C_r N
2	-	7,1	-	28,6	63,5	-	28	7	24	48	2700	9800	4750
2	-	7,1	22	-	63,5	-	-	7	18	48	2700	9800	4750
2	-	7,1	-	28,6	63,5	-	28	7	24	48	2700	9800	4750
2	-	7,1	22	-	63,5	-	-	7	18	48	2700	9800	4750
2	-	7,1	-	28,6	63,5	-	28	7	24	48	2700	9800	4750
2	-	7,1	22	-	63,5	-	-	7	18	48	2700	9800	4750
2	-	7,1	-	24,6	63,5	-	30	7	20,6	48	2700	9400	5000
2	3	8,7	-	24,6	71,4	7,5	30	14	26,1	-	4200	9400	5000
2	-	8,7	-	31	71,5	-	33	8	25,5	55	3200	12800	6600
2	-	8,7	25	-	71,5	-	-	8	20	55	3200	12800	6600
2	-	8,7	-	25,4	76	-	36	7,1	21,4	55	3000	10100	5900
2	3	8,7	-	25,4	76,2	8,5	36	16	28	-	4500	10100	5900
2	-	8,7	-	31	76,2	-	37,5	8,7	25,5	60	3650	14000	7800
2	-	8,7	27	-	76,2	-	-	8,7	21,5	60	3650	14000	7800
2,5	3,5	11,5	-	26,5	90,5	9	42,5	16	29	-	6000	13200	8300
2,5	-	10,5	-	35,7	90,5	-	44	8,7	29,2	71	5000	19500	11300
2,5	-	10,5	30	-	90,5	-	-	8,7	23,5	71	5000	19500	11300
2,5	-	10,5	-	38,9	100	-	51	10,5	31,5	81	6300	25500	15300
2,5	-	10,5	35	-	100	-	-	10,5	28	81	6300	25500	15300
3,5	-	13,5	-	43,8	119	-	58	11,5	36,2	90	7000	32500	19800
3,5	-	13,5	39,5	-	119	-	-	11,5	32,5	90	7000	32500	19800



Two-bolt flanged housing units

Sheet steel housings with rubber interliner

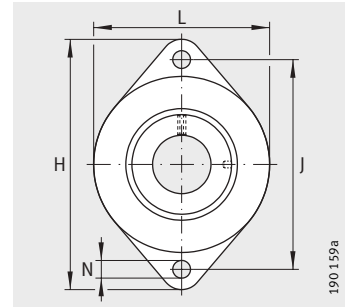

RCSMF

Dimension table · Dimensions in mm									
Designation				Mass m ≈kg	Dimensions				
Unit	Housing	Rubber interliner	Radial insert ball bearing		d	L	H	S	N
RCSMF12	FLAN65-RCSMF	RCSM40/65	RAE12-NPP	0,27	12	70	114	1,5	10,5
RCSMF15	FLAN65-RCSMF	RCSM40/65	RAE15-NPP	0,27	15	70	114	1,5	10,5
RCSMF17	FLAN65-RCSMF	RCSM40/65	RAE17-NPP	0,27	17	70	114	1,5	10,5
RCSMF20	FLAN65-RCSMF	RCSM47/65	RAE20-NPP	0,32	20	70	114	1,5	10,5
RCSMF25	FLAN65-RCSMF	RCSM52/65	RAE25-NPP	0,33	25	70	114	1,5	10,5
RCSMF30	FLAN65-RCSMF	RCSM55/65	RAE30-NPP	0,32	30	70	114	1,5	10,5

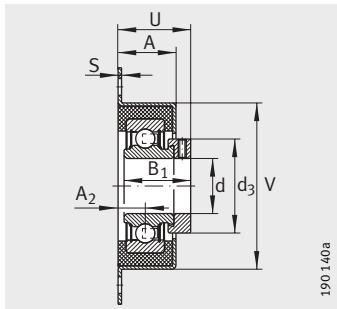

RCSMF

							Load carrying capacity of housing C_{0rG} N	Basic load ratings	
B_1	J	A_2	d_3 max.	A	U	V		dyn. C_r N	stat. C_{0r} N
28,6	92	12,7	28	27	34,8	68	900	9 800	4 750
28,6	92	12,7	28	27	34,8	68	900	9 800	4 750
28,6	92	12,7	28	27	34,8	68	900	9 800	4 750
31	92	12,7	33	27	36,2	68	1 100	12 800	6 600
31	92	12,7	37,5	27	36,2	68	1 400	14 000	7 800
26,5	92	15	42,5	27	35	68	1 400	13 200	8 300



Three-bolt flanged housing units

Sheet steel housings

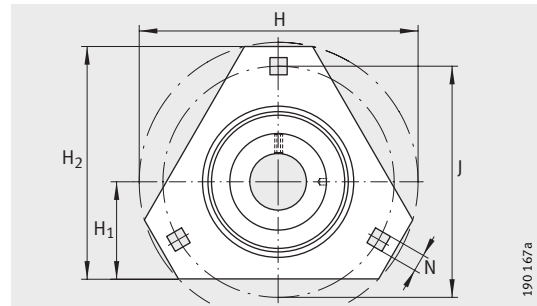

RATR, RALTR, RRTR, RATRY

Dimension table · Dimensions in mm								
Designation			Mass m ≈ kg	Dimensions				
Unit	Housing	Radial insert ball bearing		d	H ₂	H	H ₁	S ₁
RALTR20	FLAN42-LSTR (2 parts)	RALE20-NPP-B	0,21	20	76,2	90,5	33,3	2
RATR20	FLAN47-MSTR (2 parts)	RAE20-NPP-B	0,28	20	76,2	90,5	33,3	2
RRTR20	FLAN47-MSTR (2 parts)	GE20-KRR-B	0,32	20	76,2	90,5	33,3	2
RALTR25 ¹⁾	FLAN47-LSTR (2 parts)	RALE25-NPP-B	0,23	25	80,5	95,3	34,9	2
RATR25	FLAN42-MSTR (2 parts)	RAE25-NPP-B	0,32	25	80,5	95,3	34,9	2
RRTR25 ¹⁾	FLAN52-MSTR (2 parts)	E25-KRR-B	0,37	25	80,5	95,3	34,9	2
RATR30	FLAN62-MSTR (2 parts)	RAE30-NPP-B	0,43	30	93	112,7	38,1	2,5
RATRY30	FLAN62-MSTR (2 parts)	AY30-NPP-B	0,41	30	93	112,7	38,1	2,5
RRTR30 ¹⁾	FLAN62-MSTR (2 parts)	E30-KRR-B	0,5	30	93	112,7	38,1	2,5
RATR35	FLAN72-MSTR (2 parts)	RAE35-NPP-B	0,56	35	105,6	127	44,5	2,5
RATRY35	FLAN72-MSTR (2 parts)	GAY35-NPP-B	0,47	35	105,6	127	44,5	2,5
RRTR35	FLAN72-MSTR (2 parts)	E35-KRR-B	0,63	35	105,6	127	44,5	2,5

¹⁾ Housing and radial insert ball bearing must be ordered separately.

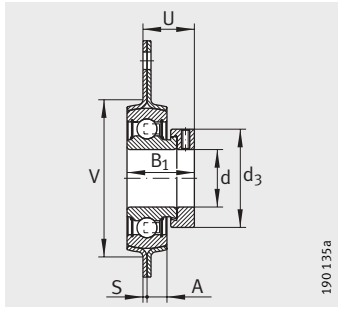

RATR, RALTR

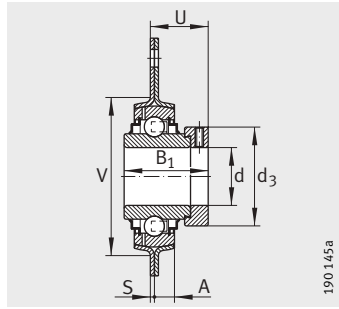

RRTR

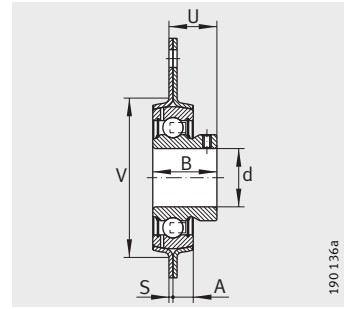

RATRY

N	B	B ₁	J	d ₃ max.	A	U	V	Load carrying capacity of housing C _{0rG} N	Basic load ratings	
									dyn. C _r N	stat. C _{0r} N
8,7	–	24,5	71,5	30	7,2	20,6	49	2 600	9 400	5 000
8,7	–	31	71,5	33	8	25,5	55	3 200	12 800	6 600
8,7	–	43,7	71,5	33	8	28,6	55	3 200	12 800	6 600
8,7	–	25,5	76	36	7,2	21,4	54	3 000	10 100	5 900
8,7	–	31	76	37,5	8,7	25,5	60	3 650	14 000	7 800
8,7	–	44,5	76	37,5	8,7	28,9	60	3 650	14 000	7 800
10,5	–	35,7	90,5	44	8,7	29,2	71	5 000	19 500	11 300
10,5	30	–	90,5	–	8,7	23,5	71	5 000	19 500	11 300
10,5	–	48,5	90,5	44	8,7	32,6	71	5 000	19 500	11 300
10,5	–	39	100	51	9,5	31,9	81	6 400	25 500	15 300
10,5	35	–	100	–	9,5	28	81	6 400	25 500	15 300
10,5	–	51,3	100	51	9,5	34,8	81	6 400	25 500	15 300



Three-bolt and four-bolt flanged housing units

Sheet steel housings

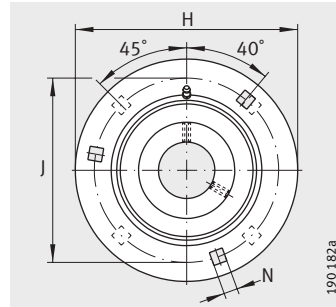

GRA, GRRY..-VA

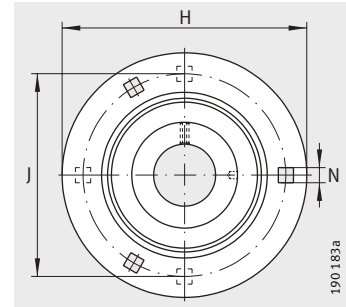

RA, RAY, RRY..-VA

Dimension table · Dimensions in mm			
Designation			Mass
Unit	Housing	Radial insert ball bearing	m ≈kg
RA12 ¹⁾	FLAN40-MSB (2 parts)	RAE12-NPP-B	0,23
RAY12 ¹⁾	FLAN40-MSB (2 parts)	AY12-NPP-B	0,17
RRY12-VA ¹⁾	FLAN40-MSB-VA (2 parts)	GYE12-KRR-B-VA	0,21
RA15	FLAN40-MSB (2 parts)	RAE15-NPP-B	0,23
RAY15	FLAN40-MSB (2 parts)	AY15-NPP-B	0,16
RRY15-VA ¹⁾	FLAN40-MSB-VA (2 parts)	GYE15-KRR-B-VA	0,2
RA17	FLAN40-MSB (2 parts)	RAE17-NPP-B	0,23
RAY17 ¹⁾	FLAN40-MSB (2 parts)	AY17-NPP-B	0,15
RRY17-VA ¹⁾	FLAN40-MSB-VA (2 parts)	GYE17-KRR-B-VA	0,19
RA20	FLAN47-MSB (2 parts)	RAE20-NPP-B	0,32
RAY20	FLAN47-MSB (2 parts)	AY20-NPP-B	0,3
GRA20	FLAN47-MSB/FLAN47-MSA (1 part each)	GRAE20-NPP-B	0,32
GRRY20-VA	FLAN47-MSB-VA/FLAN47-MSA-VA (1 part each)	GYE20-KRR-B-VA	0,34
RRY20-VA	FLAN47-MSB-VA (2 parts)	GYE20-KRR-B-VA	0,34
RA25	FLAN52-MSB (2 parts)	RAE25-NPP-B	0,37
RAY25	FLAN52-MSB (2 parts)	AY25-NPP-B	0,34
GRA25	FLAN52-MSB/FLAN52-MSA (1 part each)	GRAE25-NPP-B	0,37
GRRY25-VA	FLAN52-MSB-VA/FLAN52-MSA-VA (1 part each)	GYE25-KRR-B-VA	0,38
RRY25-VA	FLAN52-MSB-VA (2 parts)	GYE25-KRR-B-VA	0,38
RA30	FLAN62-MSB (2 parts)	RAE30-NPP-B	0,61
RAY30	FLAN62-MSB (2 parts)	AY30-NPP-B	0,45
GRA30	FLAN62-MSB/FLAN62-MSA (1 part each)	GRAE30-NPP-B	0,61
GRRY30-VA	FLAN62-MSB-VA/FLAN62-MSA-VA (1 part each)	GYE30-KRR-B-VA	0,63
RRY30-VA	FLAN62-MSB-VA (2 parts)	GYE30-KRR-B-VA	0,63
RA35	FLAN72-MSB (2 parts)	RAE35-NPP-B	0,82
RAY35	FLAN72-MSB (2 parts)	GAY35-NPP-B	0,78
GRA35	FLAN72-MSB/FLAN72-MSA (1 part each)	GRAE35-NPP-B	0,82

¹⁾ Housing and radial insert ball bearing must be ordered separately.

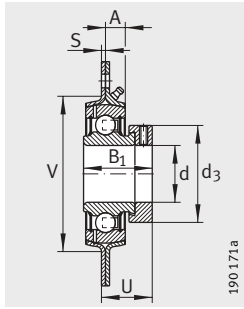

GRA

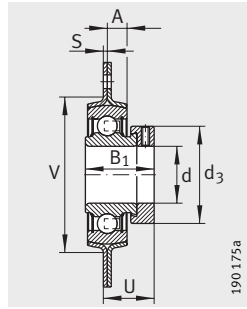

RA

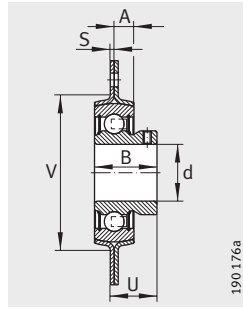

RAY

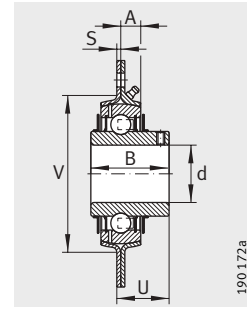

GRRY..-VA, RRY..-VA

Dimensions											Number of screw mounting holes n	Load carrying capacity of housing C _{0rG} N	Basic load ratings	
d	H	S	N	B	B ₁	J	d ₃ max.	A	U	V			dyn. C _r N	stat. C _{0r} N
12	81	2	7,1	-	28,6	63,5	28	7	24	48	3	2 700	9 800	4 750
12	81	2	7,1	22	-	63,5	-	7	18	48	3	2 700	9 800	4 750
12	81	2	7,1	25	-	63,5	-	7	17,4	48	3	2 700	9 800	4 750
15	81	2	7,1	-	28,6	63,5	28	7	24	48	3	2 700	9 800	4 750
15	81	2	7,1	22	-	63,5	-	7	18	48	3	2 700	9 800	4 750
15	81	2	7,1	25	-	63,5	-	7	17,4	48	3	2 700	9 800	4 750
17	81	2	7,1	-	28,6	63,5	28	7	24	48	3	2 700	9 800	4 750
17	81	2	7,1	22	-	63,5	-	7	18	48	3	2 700	9 800	4 750
17	81	2	7,1	25	-	63,5	-	7	17,4	48	3	2 700	9 800	4 750
20	90,5	2	8,7	-	31	71,5	33	8	25,5	55	3	3 200	12 800	6 600
20	90,5	2	8,7	25	-	71,5	-	8	20	55	3	3 200	12 800	6 600
20	90,5	2	8,7	-	31	71,5	33	8	25,5	55	3	3 200	12 800	6 600
20	90,5	2	8,7	31	-	71,5	-	8	20,3	55	3	3 200	12 800	6 600
20	90,5	2	8,7	31	-	71,5	-	8	20,3	55	3	3 200	12 800	6 600
25	95	2	8,7	-	31	76	37,5	8,7	25,5	60	3	3 650	14 000	7 800
25	95	2	8,7	27	-	76	-	8,7	21,5	60	3	3 650	14 000	7 800
25	95	2	8,7	-	31	76	37,5	8,7	25,5	60	3	3 650	14 000	7 800
25	95	2	8,7	34	-	76	-	8,7	21,7	60	3	3 650	14 000	7 800
25	95	2	8,7	34	-	76	-	8,7	21,7	60	3	3 650	14 000	7 800
30	112,7	2,5	10,5	-	35,8	90,5	44	8,7	29,2	71	3	5 000	19 500	11 300
30	112,7	2,5	10,5	30	-	90,5	-	8,7	23,5	71	3	5 000	19 500	11 300
30	112,7	2,5	10,5	-	35,8	90,5	44	8,7	29,2	71	3	5 000	19 500	11 300
30	112,7	2,5	10,5	38,1	-	90,5	-	9	24,7	71	3	5 000	19 500	11 300
30	112,7	2,5	10,5	38,1	-	90,5	-	9	24,7	71	3	5 000	19 500	11 300
35	122	2,5	10,5	-	39	100	51	9,5	31,9	81	3	6 400	25 500	15 300
35	122	2,5	10,5	35	-	100	-	9,5	28	81	3	6 400	25 500	15 300
35	122	2,5	10,5	-	39	100	51	9,5	32	81	3	6 400	25 500	15 300



Three-bolt and four-bolt flanged housing units

Sheet steel housings

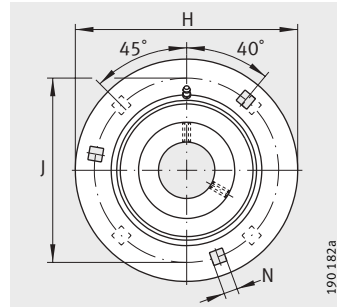

GRA

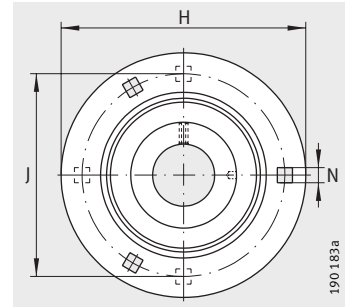

RA, RAY

Dimension table (continued) · Dimensions in mm

Designation			Mass m ≈ kg	Dimensions	
Unit	Housing	Radial insert ball bearing		d	H
RA40	FLAN80-MSB (2 parts)	RAE40-NPP-B	1,36	40	147,5
RAY40 ¹⁾	FLAN80-MSB (2 parts)	GAY40-NPP-B	1,25	40	147,5
GRA40	FLAN80-MSB/FLAN80-MSA (1 part each)	GRAE40-NPP-B	1,36	40	147,5
RA45	FLAN85-MSB (2 parts)	GRAE45-NPP-B	1,41	45	149,2
GRA45	FLAN85-MSB/FLAN85-MSA (1 part each)	GRAE45-NPP-B	1,41	45	149,2
RA50	FLAN90-MSB (2 parts)	GRAE50-NPP-B	1,68	50	155,5
RAY50 ¹⁾	FLAN90-MSB (2 parts)	GAY50-NPP-B	1,68	50	155,5
GRA50	FLAN90-MSB/FLAN90-MSA (1 part each)	GRAE50-NPP-B	1,68	50	155,5
RA55 ¹⁾	FLAN100-MSB (2 parts)	GRAE55-NPP-B	1,39	55	167
RA60 ¹⁾	FLAN110-MSB (2 parts)	GRAE60-NPP-B	2,54	60	176
RAY60 ¹⁾	FLAN110-MSB (2 parts)	GAY60-NPP-B	2,13	60	176

¹⁾ Housing and radial insert ball bearing must be ordered separately.

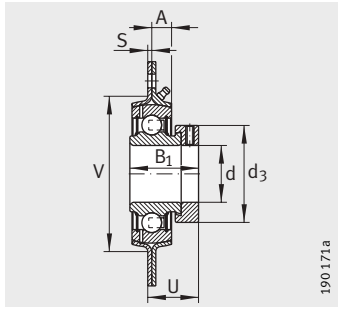

GRA

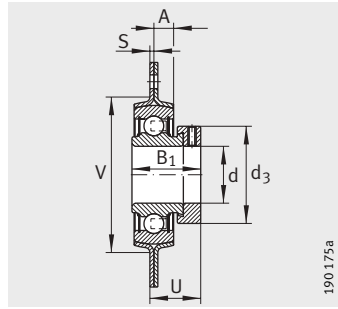

RA

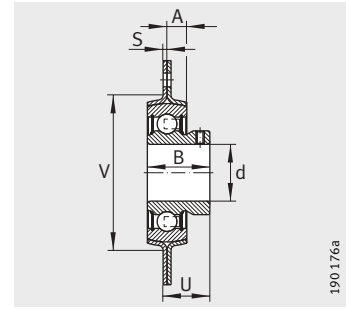

RAY

									Number of mounting holes n	Load carrying capacity of housing C_{0rG} N	Basic load ratings	
S	N	B	B ₁	J	d ₃ max.	A	U	V			dyn. C_r N	stat. C_{0r} N
3,5	13,5	-	43,8	119	58	10,3	36,2	90	4	7 700	32 500	19 800
3,5	13,5	39,5	-	119	-	10,3	32,5	90	4	7 700	32 500	19 800
3,5	13,5	-	43,8	119	58	10,3	36,2	90	4	7 700	32 500	19 800
3,5	13,5	-	43,8	120,5	63	11,1	36,2	95	4	7 700	32 500	20 400
3,5	13,5	-	43,8	120,5	63	11,1	36,2	95	4	7 700	32 500	20 400
4	13,5	-	43,8	127	69	11,1	36,7	100	4	8 600	35 000	23 200
4	13,5	43	-	127	-	11,1	36	100	4	8 600	35 000	23 200
4	13,5	-	43,8	127	69	11,1	36,7	100	4	8 600	35 000	23 200
4	13,5	-	48,4	138	76	12,5	40,4	110	4	9 500	43 500	29 000
4	13,5	-	53,1	148	84	12	43,6	120	4	11 200	52 000	36 000
4	13,5	47	-	148	-	12	38	120	4	11 200	52 000	36 000



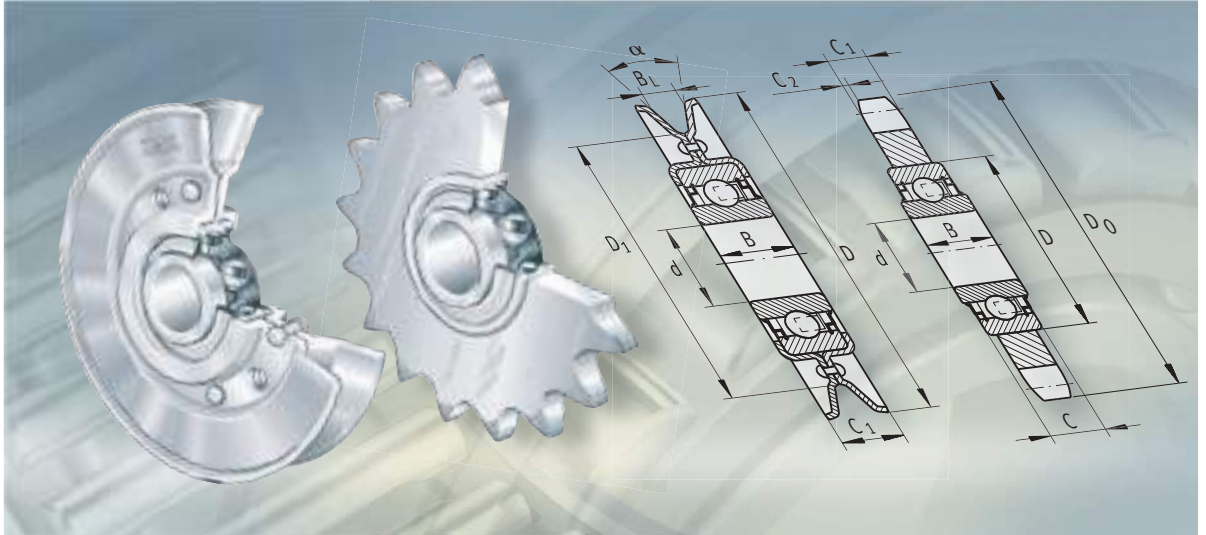

Roller chain idler sprocket units
Idler pulley units

Roller chain idler sprocket units Idler pulley units

		Page
Product overview	Roller chain idler sprocket units, idler pulley units.....	1174
Features	Roller chain idler sprocket units	1175
	Idler pulley units	1175
	Operating temperature	1175
Design and safety guidelines	Roller chain idler sprocket units	1176
	Material codes	1176
	Idler pulley units	1177
Accuracy	1177
Dimension tables	Roller chain idler sprocket units	1178
	Idler pulley units	1180



Product overview **Roller chain idler sprocket units**
Idler pulley units

Roller chain idler sprocket units

Sprocket made from steel or sintered iron

KSR..-L0



KSR..-B0



Sprocket made from plastic

KSR..-L0..-22



Idler pulley units

RSRA..-L0, RSRA..-K0

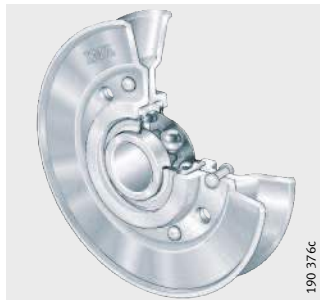

RSRB..-L0

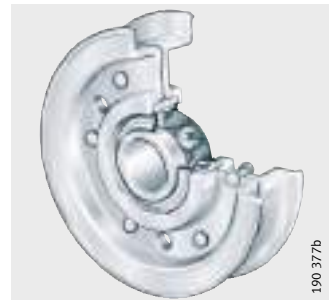

RSRD..-L0



Roller chain idler sprocket units

Idler pulley units

Features

Roller chain idler sprocket units

INA roller chain idler sprocket units are guidance and return units for roller bush chains and roller chains. They can compensate for chain stretch resulting from operation and give smoother system running under high loads and speeds.

The ready-to-fit units comprise sprockets and deep groove ball bearings or radial insert ball bearings. The sprockets are made from high strength steel, sintered iron or plastic (polyamide). Sprockets made from plastic give particularly smooth running and generate very little noise. Since the inner ring of the deep groove ball bearing is extended on both sides, no additional spacer rings are required.

In series KSR...-B0, the inner ring is located on the shaft by means of a locking collar. The bearing bore of this series has a plus tolerance. As a result, unmachined shafts up to ISO tolerance h9 can be used under moderate loads and speeds.

Sealing/lubrication

The deep groove ball bearings are sealed on both sides. They are greased using a lithium soap grease to GA13 and are maintenance-free.

Idler pulley units

Idler pulley units are tensioning systems for belt drives and idler units. They

- increase the wrap angle in belt drives and can therefore support higher power levels or allow smaller units to be used
- compensate for belt stretch resulting from operation
- allow shorter centre distances
- reduce the wear on the belt drive.

The ready-to-fit units comprise deep drawn, profiled sheet steel pulley halves riveted together and deep groove ball bearings. Pulleys of larger diameters are additionally welded together. A lead chamfer on the pulley profile prevents damage to the belt. Due to the sheet steel construction, the additional rotating masses and the imbalance masses generated are low.

Type A is suitable for vee belts,
type B for flat, vee and round belts,
type D for round belts, steel cables and hemp ropes.



Sealing/lubrication

The deep groove ball bearings are sealed on both sides. They are greased using a lithium soap grease to GA13 and are maintenance-free.

Operating temperature

Roller chain idler sprocket units with steel or sintered iron sprockets are suitable for operating temperatures from -20 °C to $+120\text{ °C}$.

Roller chain idler sprocket units with plastic sprockets are suitable for operating temperatures from -20 °C to $+80\text{ °C}$.

Idler pulley units are suitable for operating temperatures from -20 °C to $+120\text{ °C}$, limited by the grease and seal material.

Roller chain idler sprocket units Idler pulley units

Design and safety guidelines Roller chain idler sprocket units

Roller chain idler sprocket units should always be mounted on the slack side of the chain, *Figure 1*.

The wrap angle on the idler sprocket unit should be selected such that at least three teeth are engaged simultaneously.

For grease lubrication, a grease with good adhesion characteristics should be used.

Roller chain idler sprocket units of bore $d = 16$ mm are tolerated so that they can be fitted using M16 mounting screws.

Caution! The minimum press-out force of the deep groove ball bearings is 700 N. This value must not be exceeded during operation.
The preload on the slack side should not be less than 1% of the tractive force on the taut side.

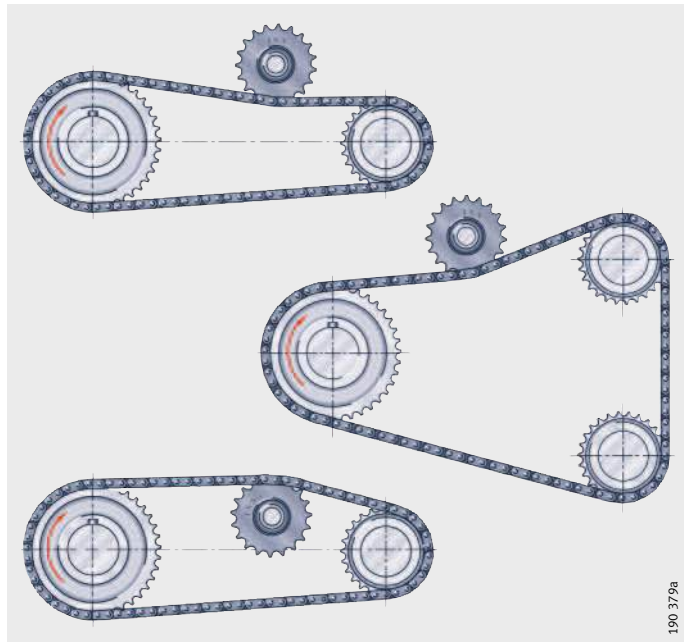

Figure 1
Arrangement on slack side of chain drive

Material codes

The materials used for the sprockets are classified by material codes, see table.

Code/material

Code	Material	Hardness
08	Sintered iron C 10	HB 50±10
09	Sintered iron D 39	HB 105±15
15	Steel St 52	–
16	Steel C 45	HRC 50±5 Tooth flanks hardened
22	Plastic PA	–

Idler pulley units

Idler pulley units should always be positioned on the slack side of the drive, *Figure 2*.

For normal loads, a light fit for the inner ring combined with axial clamping is sufficient.

If idler pulley units with a flat profile are to be used for tensioning via the back of a vee belt, check the suitability of the vee belt for this arrangement.

Caution! The permissible belt speed of 40 m/s must not be exceeded. Check the permissible strand force and life of the ball bearing for every application.

Preload force

The following is an approximate guide value for the preload S_v between the shafts:

- for flat belts
 $S_v = 2 \text{ to } 3 \times F_u$ (circumferential force)
- for vee belts
 $S_v = 1,7 \text{ to } 2,5 \times F_u$ (circumferential force).

Checking belt tension

Measure the speed ratio without load at low speed. Then measure the speed ratio at operating speed and under operating load. If the difference in speed due to slippage is $> 2\%$, retension the belt.

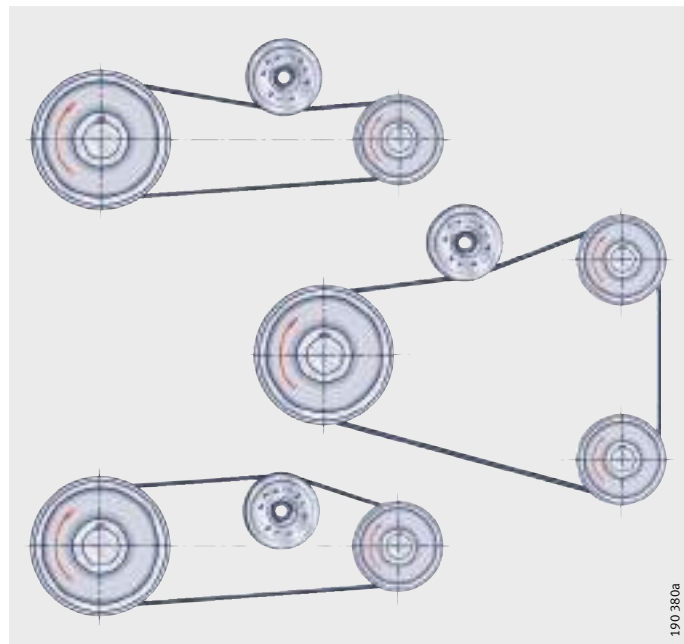
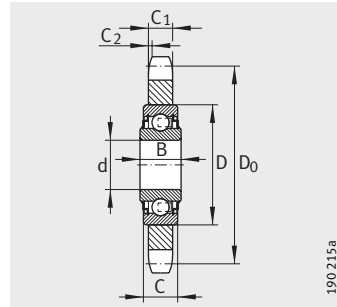

Figure 2
Arrangement
on slack side of belt drive

Accuracy

In the case of idler pulley units for vee belts, the groove angles are slightly larger due to the small wrap than recommended according to DIN 2211 and DIN 2217.

Roller chain idler sprocket units



KSR..-L0

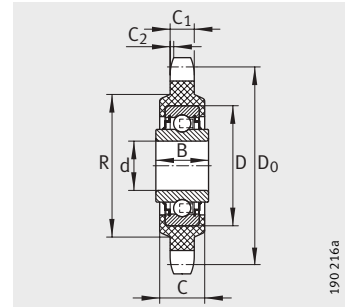

KSR..-L0..-22

Dimension table · Dimensions in mm															
Tooth set		Designation ⁴⁾⁵⁾	Mass m ≈kg	Dimensions										For chain to	
p ¹⁾ "	z ²⁾			d ³⁾	C ₁	D ₀	D _k	C _{2 min}	D	B	C	R	DIN 8187	DIN 8188	
3/8	20	KSR16-L0-06-10-20-08	0,14	16,2	5,2	60,9	65	0,8	40	18,3	12	-	*	-	
1/2	16	KSR16-L0-08-10-16-08	0,16	16,2	7	65,1	70,5	1,1	40	18,3	12	-	*	-	
		KSR16-L0-08-10-16-15	0,14	16,2	7	65,1	70,5	1,1	40	18,3	12	-	*	*	
		KSR16-L0-08-10-16-22	0,1	16,2	7	65,1	70,5	1,1	40	18,3	18,1	48	*	*	
	18	KSR16-L0-08-10-18-08	0,21	16,2	7	73,1	78,6	1,1	40	18,3	12	-	*	-	
		KSR16-L0-08-10-18-09	0,21	16,2	7	73,1	78,6	1,1	40	18,3	12	-	*	*	
		KSR16-L0-08-10-18-16	0,21	16,2	7	73,1	78,6	1,1	40	18,3	12	-	*	*	
5/8	14	KSR16-L0-10-10-14-08	0,21	16,2	8,7	71,3	78	1,3	40	18,3	12	-	*	*	
	17	KSR16-L0-10-10-17-08	0,32	16,2	8,7	86,4	93,1	1,3	40	18,3	12	-	*	*	
		KSR16-L0-10-10-17-09	0,32	16,2	8,7	86,4	93,1	1,3	40	18,3	12	-	*	*	
		KSR16-L0-10-10-17-22	0,26	16,2	8,7	86,4	93,1	1,3	40	18,3	18	48	*	*	
3/4	13	KSR16-L0-12-10-13-08	0,33	16,2	10,5	79,6	87	1,5	40	18,3	12	-	*	*	
		KSR16-L0-12-10-13-16	0,33	16,2	10,5	79,6	87	1,5	40	18,3	12	-	*	*	
	15	KSR16-L0-12-10-15-08	0,42	16,2	10,5	91,6	99,2	1,5	40	18,3	12	-	*	*	
		KSR16-L0-12-10-15-09	0,42	16,2	10,5	91,6	99,2	1,5	40	18,3	12	-	*	-	
		KSR16-L0-12-10-15-22	0,36	16,2	10,5	91,6	99,2	1,5	40	18,3	18	48	*	*	
	17	KSR16-L0-12-10-17-15	0,58	16,2	10,5	103,7	111,4	1,5	40	18,3	12	-	*	*	
		KSR16-L0-12-10-17-16	0,58	16,2	10,5	103,7	111,4	1,5	40	18,3	12	-	*	*	
	20	KSR16-L0-12-10-20-15	0,86	16,2	10,5	121,8	130	1,5	40	18,3	12	-	*	*	
1	12	KSR20-L0-16-10-12-15	0,7	20	15,3	98,1	107,6	2	47	17,7	14	-	*	*	
	KSR20-L0-16-10-12-16	0,7	20	15,3	98,1	107,6	2	47	17,7	14	-	*	-		
1 1/4	9	KSR25-L0-20-10-09-16	0,8	25	17,6	92,8	103	2,5	52	21	15	-	*	*	
	13	KSR25-L0-20-10-13-15	1,6	25	17,6	132,7	144	2,5	52	21	15	-	*	*	

1) p = pitch.

2) z = number of teeth.

3) Bore tolerance d: see table.

4) Material codes: see page 1176.

5) Composition of designation: see example, page 1179, footnote⁴⁾.

Bore tolerance

Series	Bore d mm	Tolerance mm
KSR..-L0	16,2	0 +0,1
	20 - 25	0 -0,01

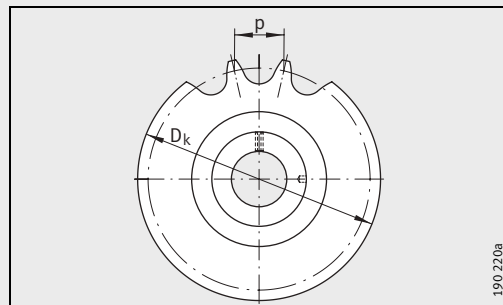

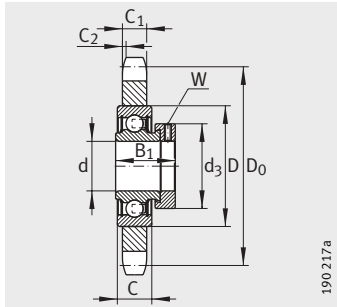

KSR..-B0

Dimension table · Dimensions in mm																
Tooth set		Designation ³⁾⁴⁾	Mass m ≈ kg	Dimensions										W	For chain to	
p ¹⁾ "	z ²⁾			d 0 +0,018	C ₁	D ₀	D _k	C _{2 min}	D	B ₁	C	d _{3 max.}	DIN 8187		DIN 8188	
³ / ₈	20	KSR15-B0-06-10-20-08	0,18	15	5,2	60,9	65	0,8	40	28,6	12	28	3	*	–	
¹ / ₂	16	KSR15-B0-08-10-16-08	0,21	15	7	65,1	70,5	1,1	40	28,6	12	28	3	*	–	
	18	KSR20-B0-08-10-18-08	0,32	20	7	73,1	78,6	1,1	47	31	14	33	3	*	*	
		KSR20-B0-08-10-18-15	0,32	20	7	73,1	78,6	1,1	47	31	14	33	3	*	*	
	19	KSR25-B0-08-10-19-08	0,29	25	7	77,1	82,5	1,1	52	31	15	37,3	3	*	*	
⁵ / ₈	14	KSR15-B0-10-10-14-08	0,26	15	8,7	71,3	78	1,3	40	28,3	12	28	3	*	*	
	17	KSR20-B0-10-10-17-15	0,41	20	8,7	86,3	93,1	1,3	47	31	14	33	3	*	*	
³ / ₄	13	KSR15-B0-12-10-13-08	0,4	15	10,5	79,6	87	1,5	40	28,6	12	28	3	*	*	
	15	KSR20-B0-12-10-15-16	0,47	20	10,5	91,6	99,2	1,5	47	31	14	33	3	*	*	
1	10	KSR20-B0-16-10-10-15	0,5	20	15,3	82,3	89,4	2	47	31	14	33	3	*	–	
	15	KSR30-B0-16-10-15-15	1,34	30	15,3	122,2	131	2	62	35,7	18	44	4	*	–	

1) p = pitch.

2) z = number of teeth.

3) Material codes: see page 1176.

4) Composition of designation taking example of **roller chain idler sprocket unit KSR15-B0-06-10-20-08**

KSR Roller chain idler sprocket unit

15 Bearing bore diameter

B0 Insert bearing with eccentric locking collar, series RAE..-NPP

06 Sprocket pitch in 1/16", code

10 Chain code (width index or relevant standard)

20 Number of teeth

08 Material code (sintered iron).



Idler pulley units

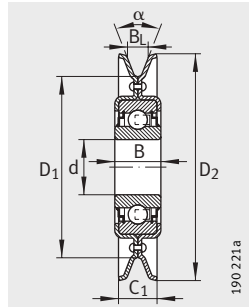

RSRA...-L0, RSRA...-K0
Type A

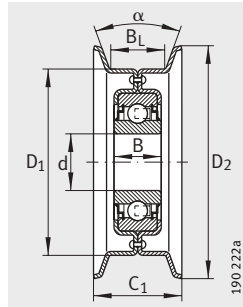

RSRB...-L0
Type B

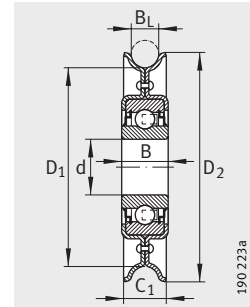

RSRD...-L0
Type D

Dimension table · Dimensions in mm

Type	Designation	Mass m ≈ kg	Dimensions						Angle α °	Vee belt size to DIN 2 215, ISO/R 434, ISO/R 608, DIN 7 753 (ISO/R 460)	Basic load ratings ²⁾	
			d ¹⁾	D ₁	D ₂	B	C ₁	B _L			dyn. C _r N	stat. C _{0r} N
A	RSRA15-90-L0	0,24	15	61,6	90	14,4	20	12,4	32	8, 10, (12,5)	7 600	3 700
	RSRA17-102-K0-AH01	0,42	17	70,8	102	12	22,2	12,7	34	8, 10, (12,5)	9 600	4 750
	RSRA13-129-L0	0,56	13	73,7	129	18,3	32	22,1	32	13, 17, 20, 22	9 800	4 750
	RSRA16-129-L0	0,54	16	73,7	129	18,3	32	22,1	32	13, 17, 20, 22	9 800	4 750
	RSRA16-186-L0	1,11	16	130,8	186	18,3	32	22,1	32	13, 17, 20, 22	9 800	4 750
B	RSRB15-92-L0	0,31	15	76,2	92	14,4	31	22,2	10	–	7 600	3 700
	RSRB13-117-L0	0,5	13	101	117	18,3	36	25,4	10	–	9 800	4 750
	RSRB16-117-L0	0,48	16	101	117	18,3	36	25,4	10	–	9 800	4 750
	RSRB13-159-L0	0,8	13	139,7	159	18,3	36,5	25,4	10	–	9 800	4 750
	RSRB16-159-L0	0,78	16	139,7	159	18,3	36,5	25,4	10	–	9 800	4 750
	RSRB16-222-L0	1,45	16	203	222	18,3	50	38	10	–	9 800	4 750
D	RSRD25-150-L0	0,83	25	133	154	21	24	17	–	–	14 000	7 800

1) Bore tolerance d: see table.

2) Basic load rating of bearing.

Bore tolerance

Bore d mm	Tolerance mm
13	+0,08 –0,05
15	0 –0,08
16	+0,26 +0,13
17	0 –0,008
25	0 –0,01



FAG

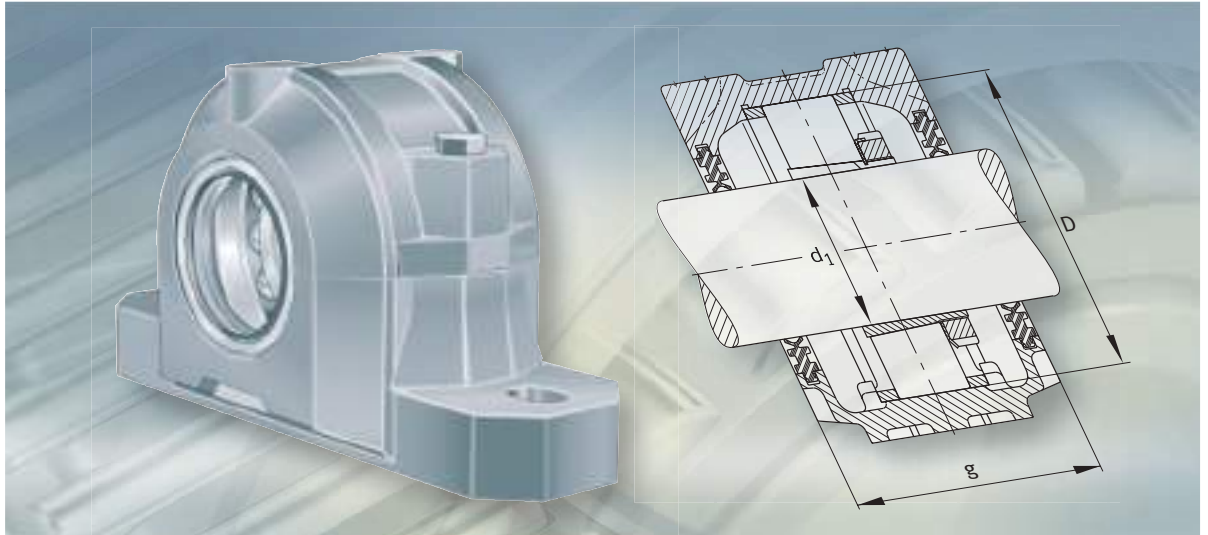

Bearing housings

Bearing housings

		Page
Product overview	Bearing housings	1184
Features	Housing materials and outer surfaces	1186
	Locating or non-locating bearings.....	1186
	Sealing.....	1186
Split and unsplit plummer block housings	Split plummer block housings SNV.....	1188
	Split plummer block housings S30	1196
	Split plummer block housings SD31	1199
	Split plummer block housings LOE for oil lubrication	1202
	Unsplit plummer block housings VR3	1204
	Unsplit plummer block housings BND	1207
Flanged housings	Flanged housings F112	1213
	Flanged housings F5.....	1214
Design and safety guidelines	Load carrying capacity of split plummer block housings	1215
	Load carrying capacity of unsplit plummer block housings	1219
	Tightening torques	1221
Accessories	Grease valves	1222
	Locating rings.....	1222
	Seals.....	1223
	Covers.....	1224
Dimension tables	Plummer block housings, SNV, split for bearings with tapered bore and adapter sleeve.....	1226
	for bearings with cylindrical bore	1262
	Plummer block housings, S30, split, for spherical roller bearings with tapered bore and adapter sleeve	1274
	Plummer block housings, SD31, split, for spherical roller bearings with tapered bore and adapter sleeve	1280
	Plummer block housings, LOE, split for spherical roller bearings with cylindrical bore	1284
	for spherical roller bearings with tapered bore and adapter sleeve	1288
	Plummer block units, VRE3, unsplit, with bearings, shaft.....	1292
	Plummer block housings, BND, unsplit, for sph. rol. brgs.....	1300
	Flanged housings, F112, unsplit, for self-aligning ball bearings with extended inner ring.....	1306
	Flanged housings, F5, unsplit, for bearings with tapered bore and adapter sleeve	1308



Product overview Bearing housings

Plummer block housings Split

SNV

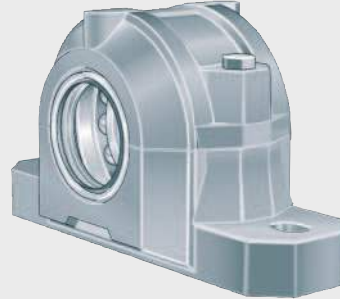

214.017a

S30

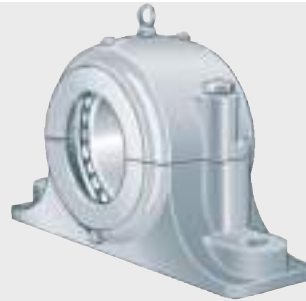

214.018a

SD31



214.019a

For oil lubrication

LOE



214.016b

Plummer block housings
Unsplit

VR3



BND



Flanged housings

F112



F5 (F505 to F513)



F5 (F515 to F522)

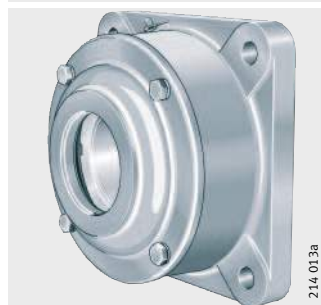

Bearing housings

Features	FAG housings and the associated bearings form bearing units that have proven successful in machinery, plant and equipment. It is only possible to show here a small selection of the numerous sizes and designs (for an overview of the FAG series housings, see publication TI WL 90-30). For other housings or housing designs, please contact Schaeffler Group Industrial.
Housing materials and outer surfaces	<p>The bearing housings are predominantly made from flake graphite cast iron. We can supply housings made from cast steel or spheroidal graphite cast iron by agreement. Since the bearings are generally lubricated with grease and the initial grease filling lasts for a long period, most housings do not have relubrication holes. However, there are cast-on bosses or marks present so that lubrication holes can be made if necessary. If relubrication is carried out, it must be ensured that excess grease is allowed to escape.</p> <p>All outer surfaces of the housings and housing parts not machined by chip-forming methods have a universal paint coating (colour RAL 7031, bluish grey). The coating can be finished using all synthetic resin, polyurethane, acrylic, epoxy resin, chlorinated rubber, nitrocellulose and acid-hardening hammer tone finishes. The anti-corrosion protection on the inner and outer surfaces machined by chip-forming methods can be easily removed.</p>
Locating or non-locating bearings	The bearing seats in the housing are generally machined such that the bearings are movable and can thus function as non-locating bearings. Locating bearing arrangements can be achieved by the insertion of locating rings if these are listed in the tables. Locating rings must be ordered separately. Housings without locating rings are supplied in a non-locating or locating bearing design.
Sealing	For the sealing of bearing housings, contact seals, non-contact seals or combinations thereof are available in order to match the operating conditions, <i>Figure 1 to Figure 3</i> .

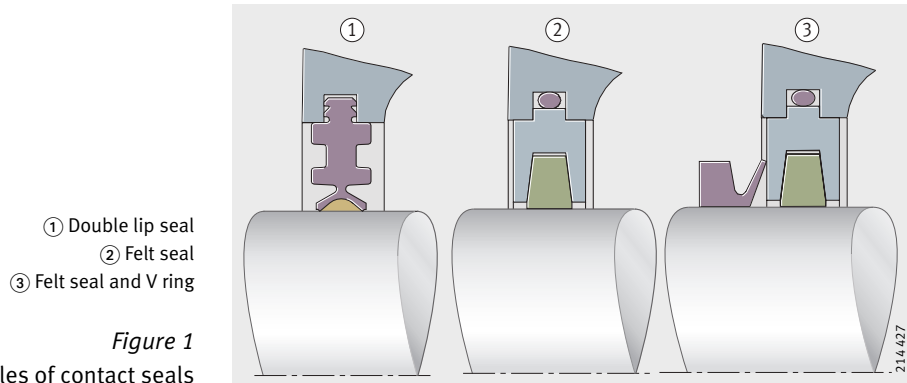

- ① Double lip seal
- ② Felt seal
- ③ Felt seal and V ring

Figure 1
Examples of contact seals

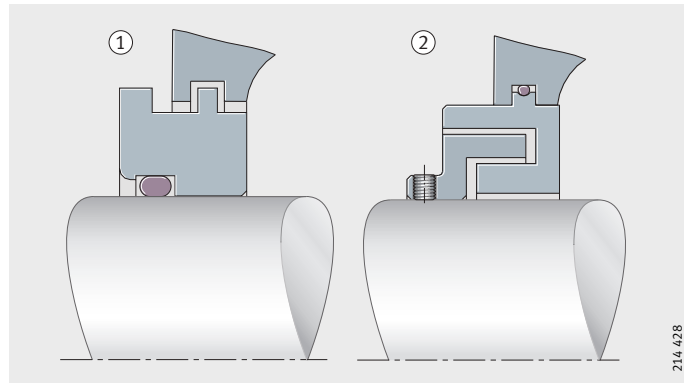

- ① Radial labyrinth
- ② Axial labyrinth

Figure 2
Examples of non-contact seals

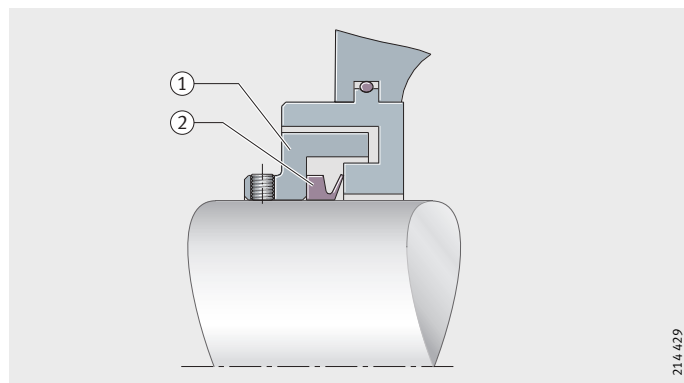

- Taconite seal, comprising
- ① Labyrinth and
 - ② V ring

Figure 3
Example of combined seals



Bearing housings

Split and unsplit plummer block housings

Split and unsplit plummer block housings are generally intended for bearing arrangements with self-aligning ball bearings, barrel roller bearings and spherical roller bearings.

In split plummer block housings, the removable upper section of the housing is centred on the lower section by dowel pins, allowing easier fitting and maintenance. The upper sections must not be interchanged with each other.

In the case of split housings, the tolerance data for bearing seats are only valid for the delivered condition, i.e. before the screws connecting the upper and lower sections are loosened.

Split plummer block housings SNV

Housings SNV are designed in accordance with a modular concept. This allows the fitting of rolling bearings of various diameter and width series.

- ① Locating bearing
- ② Non-locating bearing
- ③ TSV, ④ DH, ⑤ DKV, ⑥ FSV

Figure 4

Housing SNV for bearings with tapered bore and adapter sleeve

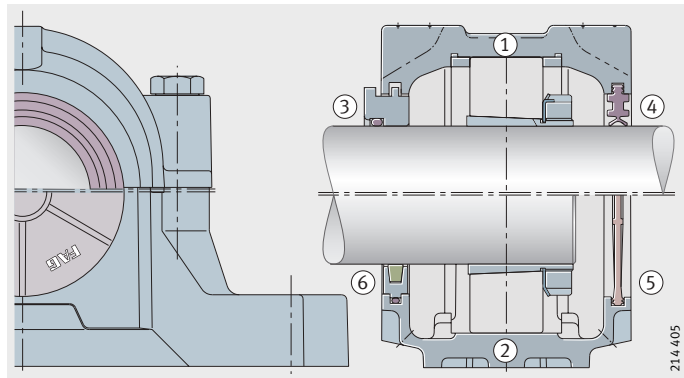

- ① Locating bearing
- ② Non-locating bearing
- ③ TSV, ④ DH, ⑤ DKVT, ⑥ FSV

Figure 5

Housing SNV for bearings with cylindrical bore

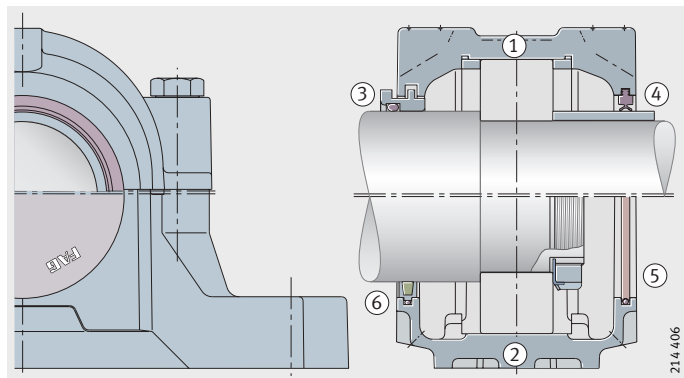

For example, the housing SNV160 can accommodate various bearing types with angular adjustment, namely self-aligning ball bearings, barrel roller bearings and spherical roller bearings, from 20 bearing series; all bearings with the same outside diameter of 160 mm. Housings SNV can also accommodate deep groove ball bearings and split spherical roller bearings.

Bearings from different diameter series with the same outside diameter have different bore diameters.

In addition, the method of locating the bearing on the shaft is also significant:

- direct seating or location using an adapter also results in different shaft diameters.

In housings SNV, this gives different sizes of gap between the shaft and housing bore, depending on the bearing fitted. This gap is taken up by the seal.

The dimension tables indicate the suitable seals and covers for the bearings listed. If the housing bore allows a different bearing to be used, the seals must be selected as appropriate.

From size SNV215, the housings have an eye bolt that must not be loaded to a value greater than the mass of the housing including the bearing.

The essential advantages of housings SNV are:

- Simplified stockholding as a result of the modular concept. One housing size is suitable for various shaft diameters.
- High load carrying capacity, see page 1216.
- Depending on the operating conditions, double lip seals, V ring seals, labyrinth seals, felt seals or combined seals may be used. Special seals are available by agreement.
- Locating bearings centred by means of two locating rings of identical width.
- If high forces do not act on the locating face in a purely vertical direction, the housing can be abutted against stops due to the flat end faces on the housing base.
- Holes can be created at marked points on the housing for: lubrication and monitoring systems, fixing screws, parallel or tapered pins.



Dimensions, material

The dimensions of housings SNV correspond to ISO 113/II and, with the exception of the width, also to DIN 736 to DIN 739. The housings are interchangeable with the existing housings SN(E). The housings SNV listed in the tables are made from flake graphite cast iron (suffix L). Housings made from spheroidal graphite cast iron (suffix D) are available by agreement.

Bearing seat and fitting of bearings

The bearing seat in the housing SNV is machined to H7. The bearings are movable and thus function as non-locating bearings. Locating bearing arrangements are achieved by inserting one locating ring (FRM) on each side of the bearing; the bearing is thus seated in the centre of the housing. Housings SNV can accommodate rolling bearings that are seated directly on a stepped shaft or on an adapter sleeve.

Bearing housings

Seals and covers	<p>Seals and covers are fitted in the rectangular-section annular slots on both sides of housings SNV. The seals must be ordered separately. They are principally suitable for grease lubrication.</p> <p>The standard seal for housings SNV is the double lip seal DH. Other types available upon request are V ring seals DHV, labyrinth seals TSV, felt seals FSV, combined seals TCV and special seals.</p>
Double lip seal DH	<p>The double lip seal DH made from NBR is suitable for circumferential speeds up to 13 m/s. The two-part seal can be easily inserted in the annular slots in the housing (pay attention to the position of the joint). The seal lips slide on the rotating shaft. The outer seal lip prevents ingress of contamination into the bearing arrangement. This effect is supported by the grease held between the seal lips. The inner lip prevents lubricant from escaping from the housing. The double lip seal allows shaft misalignment of up to 0,5° in both directions. It is suitable for temperatures from -40 °C to +100 °C. The contact area on the shaft for the seal lips should have a roughness to class N8 (DIN ISO 1302).</p>
V ring seal DHV	<p>In V ring seals DHV made from NBR, the seal lip is in axial contact with the sliding surface. The seal allows misalignment of up to 0,5° in both directions and is suitable, if grease lubrication is used, for a circumferential speed up to 12 m/s (at > 8 m/s, axial location is necessary).</p>
Labyrinth rings TSV	<p>Labyrinth rings of series TSV are suitable for higher circumferential speeds since they are of a non-contact type. The O ring pressed between the labyrinth ring and the shaft ensures that the labyrinth ring does not slip despite the loose fit. The O ring made from Viton® is suitable for temperatures up to +200 °C. The labyrinth seal allows shaft misalignment of up to 0,5° in both directions. If necessary, the labyrinth can be relubricated.</p>
Felt seals FSV	<p>FAG felt seals FSV are suitable for grease lubrication and temperatures up to +100 °C (by agreement, aramide packing is available for high temperatures). The adapter holding the inserted, oil-impregnated felt strip is secured against rotation by an O ring in the housing slot. Felt seals are suitable for circumferential speeds up to 5 m/s and, after running-in, up to 15 m/s. The permissible shaft misalignment is 0,5° in both directions.</p>
Covers DKV	<p>If housings SNV are to be closed off on one side, covers DKV must be ordered specially. The plastic covers are suitable for long term operating temperatures up to +120 °C. Covers DKVT for higher temperatures are available by agreement.</p>

Grease lubrication

In many applications, bearings can be lubricated for life, i.e. the grease quantity introduced at assembly is sufficient for the entire bearing life when contact seals are used (e.g. DH, FSV). The bearings are filled completely with grease while the housing cavities are filled to 60%. Grease quantity for initial filling: see table Recommended grease quantity for initial filling of housings SNV, page 1192 (housing cavities filled to 60%, bearing filled completely).

For bearing operating temperatures $< +100\text{ }^{\circ}\text{C}$, bearing loads $P/C < 0,3$ and a bearing specific speed parameter $k_a \cdot n \cdot d_M < 700\,000\text{ min}^{-1} \cdot \text{mm}$, the most suitable rolling bearing grease is Arcanol MULTITOP, a lithium soap grease to NLGI class 2 with particularly effective EP additives, see also publication no. WL 81 116.

For a speed parameter $n \cdot d_M < 50\,000\text{ min}^{-1} \cdot \text{mm}$ and a non-contact seal (e.g. TSV), where the grease should also perform a sealing function, the housing and seal cavities should be filled to approx. 100%.

If the achievable fatigue limit life of the bearing is significantly longer than the grease operating life, the existing grease must be removed and replaced by fresh grease.

If the grease change intervals for particular applications are too short, relubrication is recommended. The lubricant can be introduced into the housing from the side or, in the case of bearings with a lubrication slot and lubrication holes, through the centre.

If relubrication is carried out from the side, the housing cavities on the side with the lubrication nipple should be filled to approx. 100% with grease so that the relubrication grease can act immediately on the bearing. Depending on the seal selected and the application, the housing can be fitted at marked locations with devices for the inlet and outlet of lubricant.

Housings ordered using the suffix G944A* have a lubrication nipple and grease outlet hole. Position and dimensions of the holes and lubrication nipple see *Figure 6*, page 1193.

In housings with a grease outlet hole or non-contact seal, the bearing cannot be overlubricated. If the temperature level is higher at relubrication due to the churning energy of the grease, this will return to its original level after a few hours' running time, once the excess grease has escaped. In the interests of the environment, controlled metering of lubricant is recommended.

Due to their favourable flow behaviour, greases of consistency class 2, e.g. Arcanol MULTITOP and MULTI2, are more suitable for relubrication than greases of higher consistency classes.



Bearing housings

Recommended grease quantity for initial filling of housings SNV (housing cavities filled to 60%, bearing filled completely)

Housing	Grease quantity Initial filling ≈g
SNV052	30
SNV062	45
SNV072	65
SNV080	80
SNV085	105
SNV090	130
SNV100	180
SNV110	210
SNV120	270
SNV125	290
SNV130	330
SNV140	440
SNV150	500
SNV160	650
SNV170	700
SNV180	900
SNV190	950
SNV200	1 200
SNV215	1 400
SNV230	1 600
SNV240	1 700
SNV250	2 000
SNV260	2 000
SNV270	2 500
SNV280	2 600
SNV290	3 000
SNV300	3 100
SNV320	3 700
SNV340	4 500

- ① Lubrication nipple (example)
- ② Outlet hole

Figure 6

Recommended dimensions for lubrication nipple connector hole and grease outlet hole

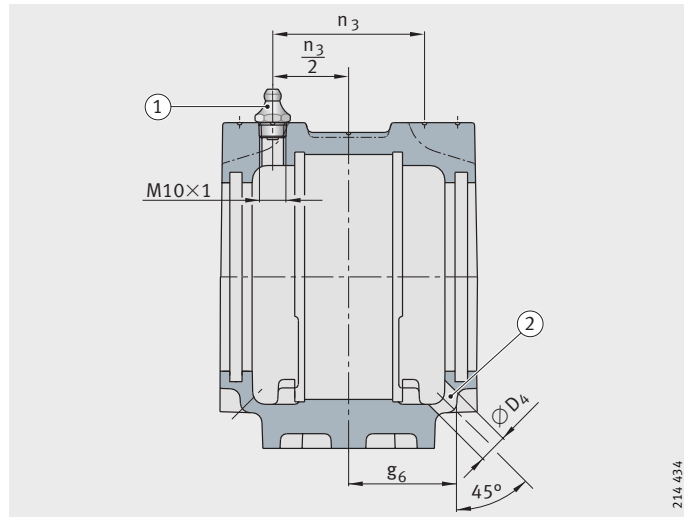

Recommended dimensions for lubrication nipple connector hole and grease outlet hole

Housing	Connector for lubrication nipple $\frac{n_3}{2}$ mm	Grease outlet hole	
		D_4 mm	g_6 mm
SNV052	19	10	27,5
SNV062	21	10	30
SNV072	23	10	33
SNV080	26	10	36
SNV085	23,5	10	34,5
SNV090	29	10	41,5
SNV100	31	15	44
SNV110	33,5	15	46
SNV120	35,5	15	49
SNV125	28,5	10	41
SNV130	38	15	51,5
SNV140	40,5	15	57,5
SNV150	42,5	15	60
SNV160	45	15	62,5
SNV170	46,5	20	64
SNV180	49,5	20	69
SNV190	49,5	20	68,5
SNV200	55,5	20	77,5
SNV215	58,5	20	80
SNV230	61	20	83
SNV240	60	20	81,5
SNV250	65,5	20	89
SNV260	62,5	20	84
SNV270	71,5	20	96,5
SNV280	68	20	92,5
SNV290	76	20	102,5
SNV300	73	20	99,5
SNV320	77	20	104,5
SNV340	81	20	109,5



Bearing housings

Housings SNV for grease relubrication (suffix G944A*, available by agreement) have a lubrication nipple and an outlet hole of the dimensions given in the table, see table on page 1193. Example: design G944AA with taper type lubrication nipple NIP.DIN 71 412-AM10×1.

Grease valves RSV

For operation at high speeds, e.g. in fan bearing arrangements, we can by agreement supply grease valves RSV, see *Figure 7* and *Figure 8*.

The grease valves for housings SNV of design G944A* must be ordered separately. For bearings located by means of adapter sleeves, grease valves RSV5 or RSV6 should be used, for bearings with a cylindrical bore RSV2 or RSV3 should be used.

- ① RSV2, RSV3
- ② RSV5, RSV6

Figure 7
Grease valves RSV

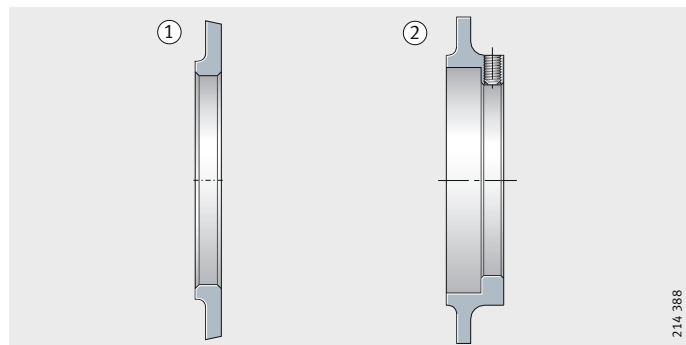

214 368

- ① RSV2, RSV3
 - ② RSV5, RSV6
- b = valve width

Figure 8
Grease valves RSV
Mounting position

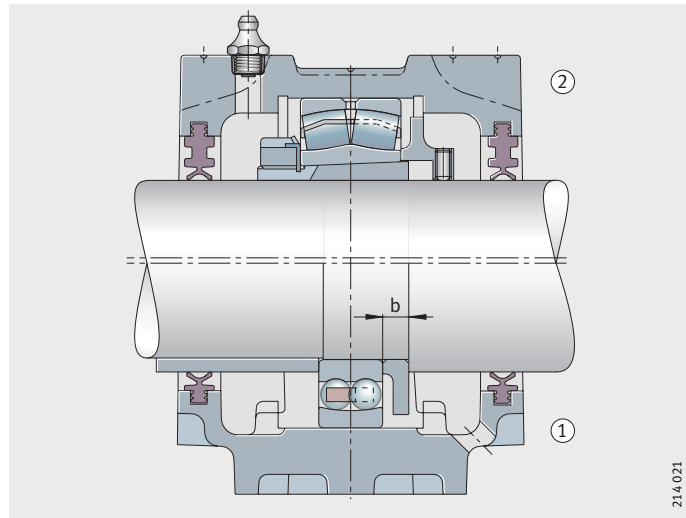

214 021

Dimensions of grease valves RSV

Grease valve	Width b mm
RSV205 to RSV211	8
RSV212 to RSV218	10
RSV219 to RSV222	13
RSV224 to RSV232	15
RSV305 to RSV308	8
RSV309 to RSV313	10
RSV314 to RSV316	13
RSV317 to RSV322	15
RSV324 to RSV332	16

Oil lubrication

Housings SNV are designed such that they are suitable for both oil bath and recirculating oil lubrication. The housings have a large internal cavity with oil collector pockets in the lower section as well as connector facilities for oil inlet, oil outlet, oil level sensors and temperature sensors. When using oil bath lubrication, a minimum oil level must be ensured. If the FAG double lip seal is used, a certain amount of oil leakage must be expected, which is unavoidable with seals that are split and not spring-loaded. In order to limit oil leakage to a small quantity, the shaft in the double lip contact areas should be as follows: hardness min. 55 HRC, ground free from spiral marks with $R_a = 0,2 \mu\text{m}$ to max. $0,5 \mu\text{m}$.

The parting line between the upper and lower sections of the housing must be sealed with a thin layer of a commercial sealant (with permanent elasticity).

Caution!

Please note that the housing must be ventilated if oil bath lubrication is used (for example, the inlet hole can be closed off using a ventilation plug).



Bearing housings

Split plummer block housings S30

Split plummer block housings for spherical roller bearings 230...K with tapered bore and adapter sleeve, *Figure 9 to Figure 12.*

- ① Locating bearing
- ② Non-locating bearing
- ③ Cover DK

Figure 9

Plummer block housing S30 up to and including size S3040 with cover DK

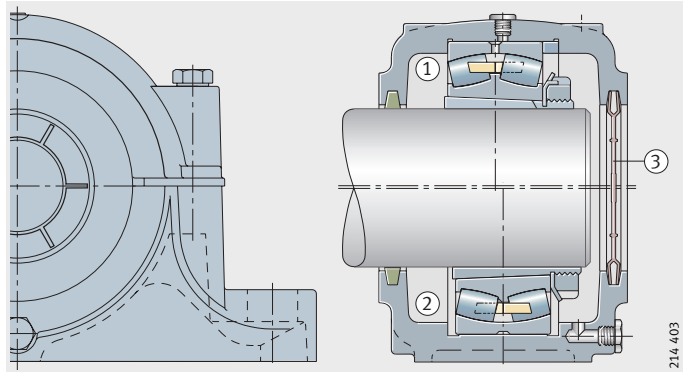

- ① Locating bearing
- ② Non-locating bearing

Figure 10

Plummer block housing S30 up to and including size S3040 without cover DK

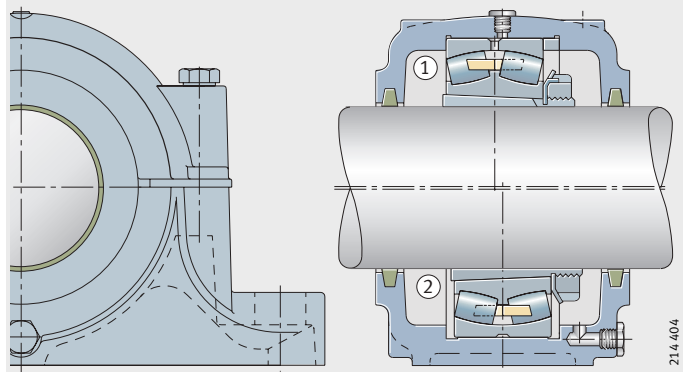

- ① Locating bearing (AF)
- ② Non-locating bearing (AL)

Figure 11

Plummer block housing S30 from size S3044, design A

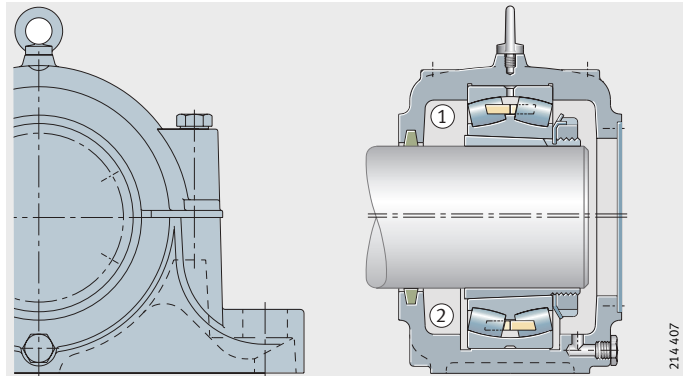

- ① Locating bearing (BF)
- ② Non-locating bearing (BL)

Figure 12
Plummer block housing S30
from size S3044,
design B

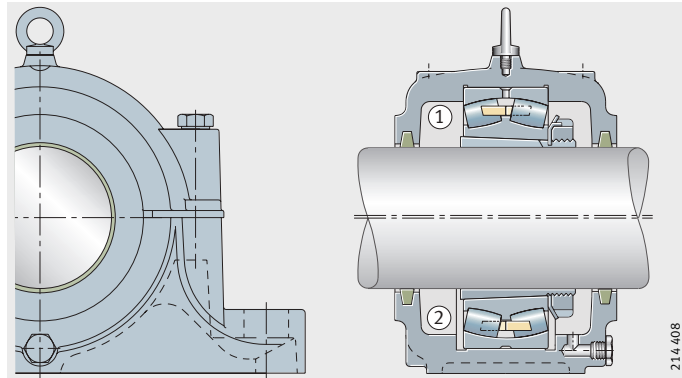

Plummer block housings of series S30 for spherical roller bearings of series 230..-K with tapered bore and adapter sleeve

The smaller housings including S3040 are non-locating bearing housings, i.e. locating bearing arrangements can be achieved by inserting a locating ring. Locating rings must be ordered separately. Housings closed on one side up to size S3040 have a polyamide cover inserted in the slot instead of the felt strip. This cover must be ordered separately.

The larger housings from S3044 are produced as non-locating bearing housings or as locating bearing housings. When ordering housings closed on one side, design A must be indicated in the order. The cover is made from steel. Housings of design B are intended for continuous shafts.

The housings are sealed using felt strips. Felt seals allow shaft misalignment of up to 0,5° in both directions.

Housings of series S30 can be relubricated via a lubrication connector in the centre of the housing. From size S3034, the housings have a ring bolt that must not be loaded to a value greater than the mass of the housing including the bearing.

The housing material is flake graphite cast iron (suffix L).

Load carrying capacity: see also Load carrying capacity of split plummer block housings, page 1217.

Caution! The maximum axial load carrying capacity is 35% of F_{180° .



Bearing housings

Recommended grease quantity for initial filling of housings S30 (housing cavities filled to 60%, bearing filled completely)

Housing	Grease quantity Initial filling ≈g
S3024	390
S3026	560
S3028	630
S3030	730
S3032	970
S3034	1 100
S3036	1 300
S3038	1 300
S3040	2 000
S3044	2 700
S3048	2 700
S3052	3 700
S3056	4 200
S3060	5 200
S3064	5 500
S3068	6 800
S3072	7 200
S3076	8 600
S3080	10 400
S3084	12 000
S3088	13 200
S3092	14 600
S3096	15 100

Split plummer block housings SD31

Split plummer block housings for spherical roller bearings 231...-K with tapered bore and adapter sleeve, *Figure 13 to Figure 16.*

- ① Locating bearing
- ② Non-locating bearing

Figure 13

Plummer block housing SD31 up to and including size SD3140, design A

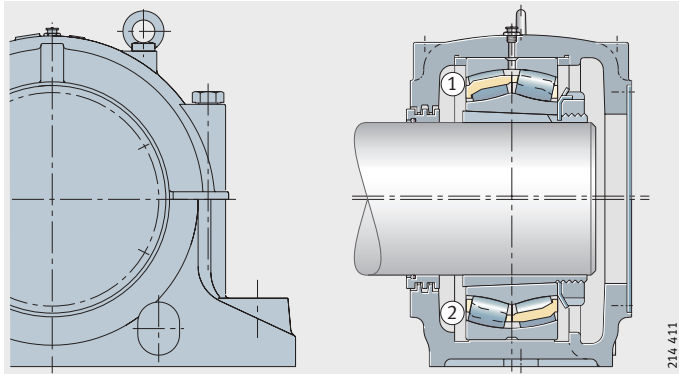

- ① Locating bearing
- ② Non-locating bearing

Figure 14

Plummer block housing SD31 up to and including size SD3140, design B

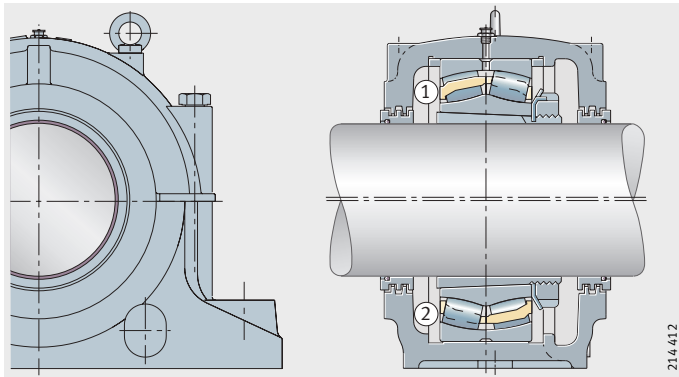

- ① Locating bearing (AF)
- ② Non-locating bearing (AL)

Figure 15

Plummer block housing SD31 from size S3144, design A

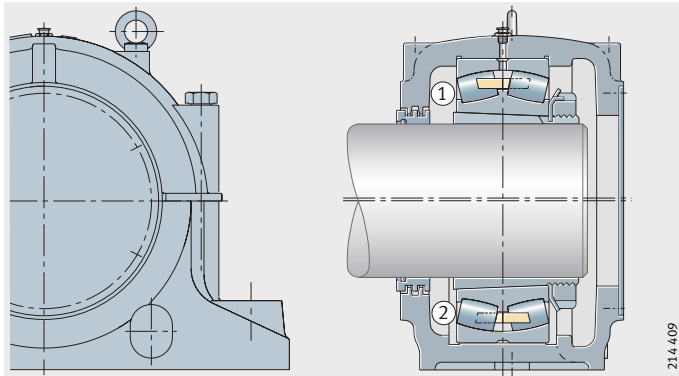

Bearing housings

- ① Locating bearing (BF)
- ② Non-locating bearing (BL)

Figure 16
Plummer block housing SD31
from size SD3144,
design B

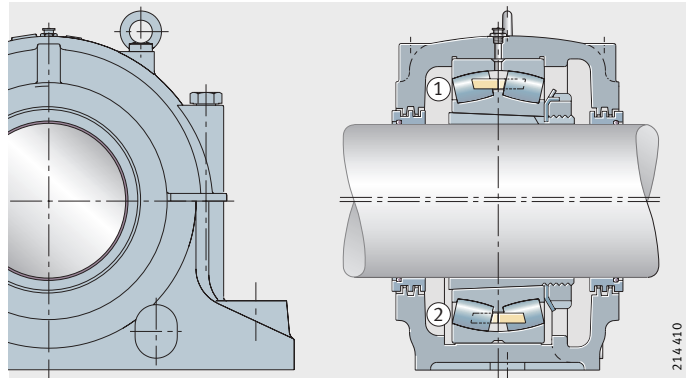

Plummer block housings of series SD31 for spherical roller bearings of series 231..-K with tapered bore and adapter sleeve

These housings are intended for bearing arrangements subjected to heavy loads. The bearings are located on the shaft by means of adapter sleeves.

From SD3144, the housings are supplied as a locating bearing design or non-locating bearing design. Smaller housings initially give non-locating bearing arrangements. Locating bearing arrangements can be achieved by the insertion of locating rings on both sides of the bearing. Locating rings must be ordered separately.

The housings are intended for grease lubrication and can be relubricated via a lubrication nipple.

For the holes required for oil lubrication, the upper and lower section of the housings have cast-on bosses.

The seal is a three-section labyrinth. Labyrinth seals allow shaft misalignment of up to 0,25° in both directions. Housings closed on one side (design A) are supplied with a steel cover.

The ring bolts in the upper section of the housing must not be loaded to a value greater than the mass of the housing including the bearing.

The housing material is flake graphite cast iron (suffix L).

Load carrying capacity: see also Load carrying capacity of split plummer block housings, page 1218.

Caution! The maximum axial load carrying capacity is $\frac{2}{3}$ of F_{180° .

Recommended grease quantity for initial filling of SD31 housings (housing cavities filled to 60%, bearing filled completely)

Housing	Grease quantity Initial filling ≈g
SD3134	1 700
SD3136	2 100
SD3138	2 800
SD3140	3 600
SD3144	4 200
SD3148	5 200
SD3152	6 700
SD3156	7 000
SD3160	10 000
SD3164	12 000
SD3168	18 000
SD3172	18 000
SD3176	23 000
SD3180	23 000
SD3184	32 000
SD3188	32 000
SD3192	40 000
SD3196	40 000



Bearing housings

Split plummer block housings LOE for oil lubrication

Split plummer block housings LOE are designed for oil lubrication. Plummer block housings LOE2 and LOE3 are fitted with spherical roller bearings with a cylindrical bore of series 222 and 223, *Figure 17* and *Figure 18*.

The bearings are located on the shaft using an interference fit and axially secured by means of a locknut.

- ① Locating bearing (AF)
- ② Non-locating bearing (AL)

Figure 17
Plummer block housings LOE2, LOE3, design A

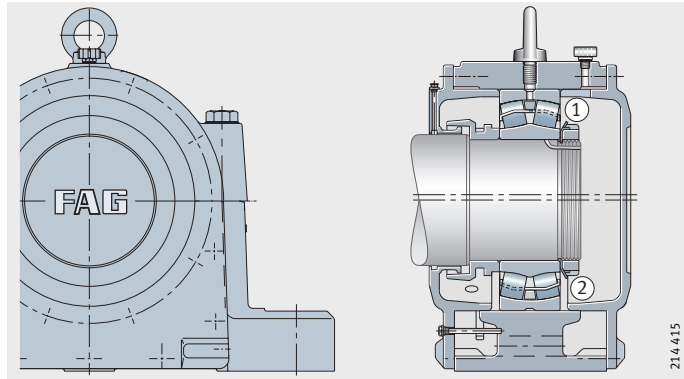

- ① Locating bearing (BF)
- ② Non-locating bearing (BL)

Figure 18
Plummer block housings LOE2, LOE3, design B

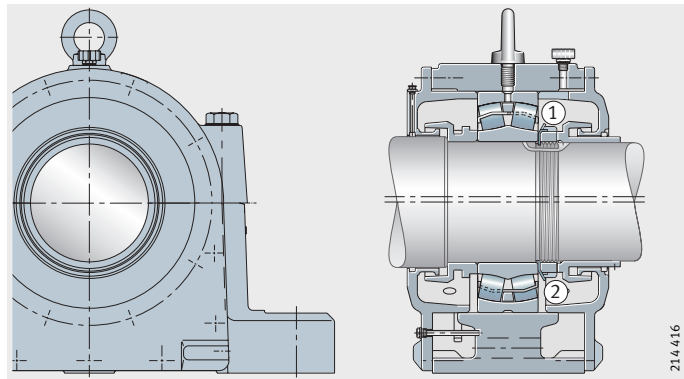

LOE plummer block housings LOE5 and LOE6 are intended for spherical roller bearings with tapered bore and adapter sleeve location, *Figure 19* and *Figure 20*.

- ① Locating bearing (AF)
- ② Non-locating bearing (AL)

Figure 19
Plummer
block housings LOE5, LOE6,
design A

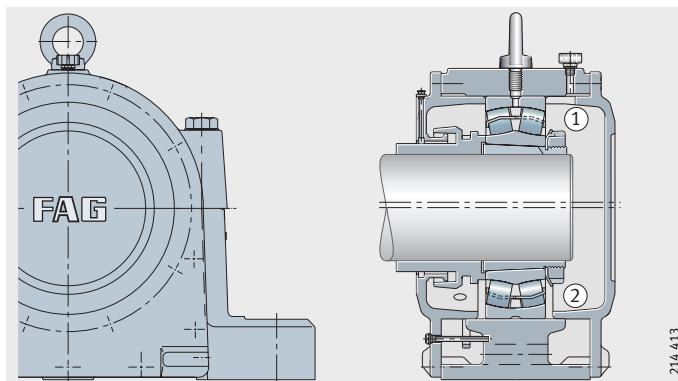

- ① Locating bearing (BF)
- ② Non-locating bearing (BL)

Figure 20
Plummer
block housings LOE5, LOE6,
design B

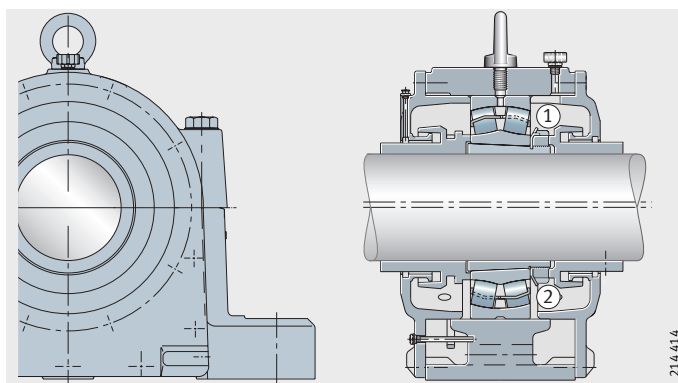

The housing is split, the labyrinth covers are unsplit. The seal comprises two labyrinth rings. Labyrinth seals allow shaft misalignment of up to $0,25^\circ$ in both directions. The grease chamber in the cover labyrinth can be relubricated. The housing base has four extended slots.

Plummer block housings of series LOE are suitable for high-speed bearing arrangements and are designed for oil lubrication. The oil is supplied to the rolling bearing from the oil sump in the lower section of the housing by a ring oiler. An angled oil level indicator is screwed to one cover.

Housings of series LOU for recirculating oil lubrication are available by agreement.

The ring bolt in the upper section of the housing must not be loaded to a value greater than the mass of the housing including the bearing.

The housing material is flake graphite cast iron (suffix L).



Bearing housings

Unsplit plummer block housings VR3

Plummer block housings VR3 are fitted with rolling bearings with a cylindrical bore, *Figure 21 to Figure 26*. The variants of these housings are available completely assembled and greased as bearing units VRE3.

Housing VR3..-A
2 deep groove ball bearings
in floating arrangement
Shaft VRW3..-A

Figure 21
Unit VRE3..-A

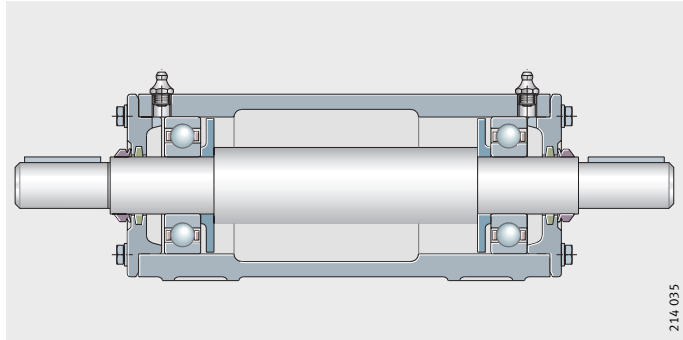

Housing VR3..-A
1 deep groove ball bearing and
1 cylindrical roller bearing NJ
in floating arrangement
Shaft VRW3..-A

Figure 22
Unit VRE3..-B

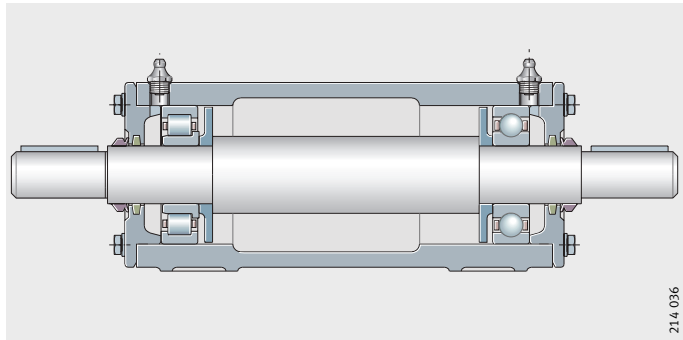

Housing VR3..-C
Locating/non-locating bearing
arrangement with
1 cylindrical roller bearing NU and
2 angular contact ball bearings
in O arrangement
Shaft VRW3..-C

Figure 23
Unit VRE3..-C

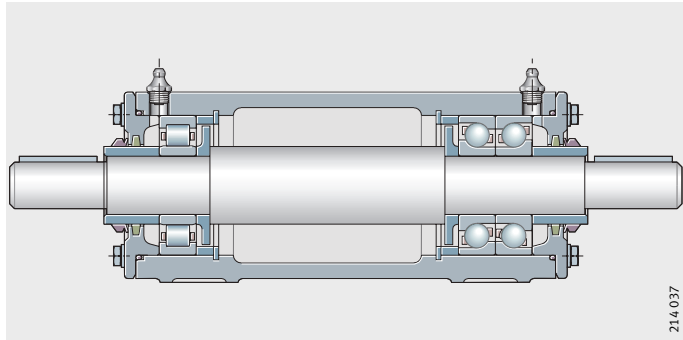

From size VR(E)310, the housings have two ring bolts that must not be loaded to a value greater than the mass of the housing including the bearing and shaft. After mounting, the ring bolts can be replaced by the hexagon head bolts with seals included in the packaging.

Housing VR3..-D
 Locating/non-locating bearing
 arrangement with
 1 cylindrical roller bearing NU and
 1 deep groove ball bearing
 Shaft VRW3..-D

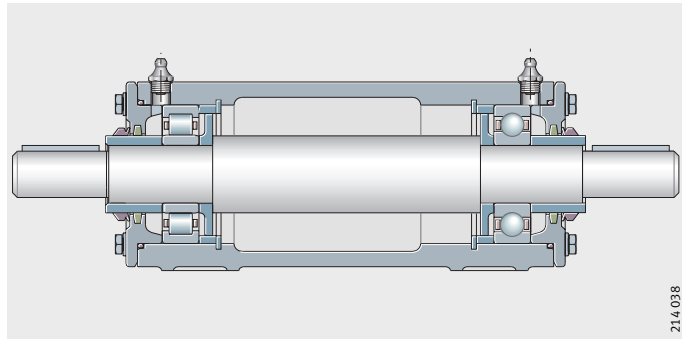

Figure 24
 Unit VRE3..-D

214_038

Housing VR3..-E
 Locating/non-locating bearing
 arrangement with
 1 cylindrical roller bearing NU,
 1 cylindrical roller bearing NU and
 1 deep groove ball bearing
 Shaft VRW3..-C

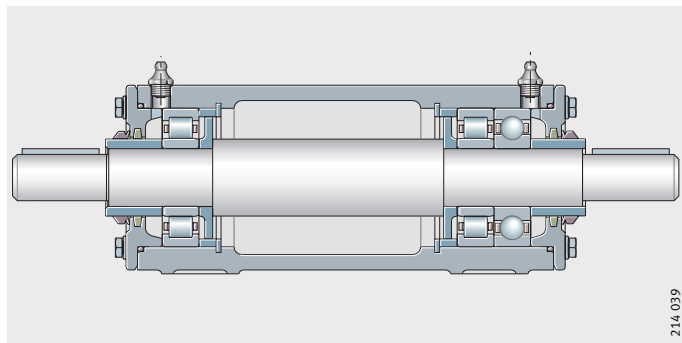

Figure 25
 Unit VRE3..-E

214_039

Housing VR3..-F
 2 deep groove ball bearings
 in floating arrangement,
 axially adjusted by spring between
 outer ring and housing cover
 Shaft VRW3..-F

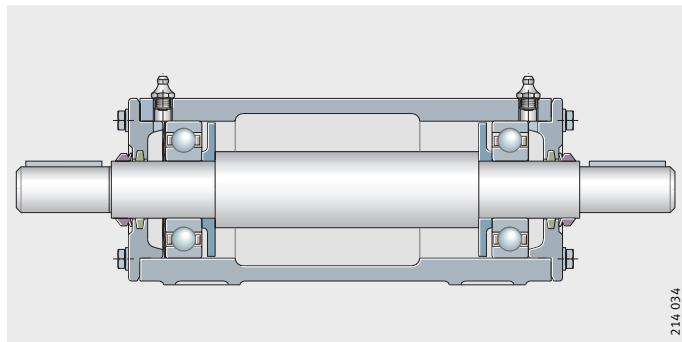

Figure 26
 Unit VRE3..-F

214_034



These unsplit housings, developed for fan applications, contain two bearing positions. They are used where a precise and easy-to-fit bearing arrangement is required, for example in:

- conveying equipment
- test rigs
- materials processing machinery
- belt drives
- laboratory equipment
- textile machinery
- feeder mechanisms.

Bearing housings

All variants of housings VR3 are available completely assembled and greased as bearing units VRE3. They can be integrated directly in existing machinery without substantial preparation. The shaft diameter range extends from 25 mm to 120 mm.

Advantages of bearing units VRE3:

- Easy to fit
- Low maintenance requirements
- Effective, low-friction sealing against dust and moisture (permissible operating temperature +100 °C)
- Bearing arrangement contained in single-piece housing, therefore requiring no time-consuming alignment work
- High tilting moments supported by two bearings with optimum spacing
- Six designs allow matching to different load conditions.

In addition to complete bearing units VRE3, the following are also available:

- housings VR3 with covers, grease valves, lubrication nipples, seals, locating elements and, if necessary, a spring washer
- shafts VRW with locating elements
- rolling bearings.

Areas of application of designs

Design A is suitable for predominantly radial load and high speed. It can support axial loads in both directions (not alternating).

Design B is suitable for high radial load on one side. It can only support axial forces in one direction.

Design C is suitable for high radial load on one side. It can support high axial forces in both directions.

Design D is suitable for axial loads in both directions.

Design E is suitable for high radial loads on both sides and axial loads in both directions.

Design F is suitable for predominantly radial load and high speed. It can support axial load in one direction (facing away from the spring).

Marking

A cast-on boss on the housing body indicates:

- the position of the cylindrical roller bearing in design B,
- the position of the non-locating bearing in designs C, D and E,
- the position of the ondular washer in design F.

The position of the ondular washer is also indicated on the shaft VRW3...-F.

The housing is made from flake graphite cast iron, the shaft is made from steel.

Further information

Further information on lubrication and sealing, fitting and maintenance of VRE units is given in publication no. WL 90121, FAG Bearing Units for Fans, Series VRE3.

Unsplit plummer block housings BND

Unsplit FAG housings of series BND are combined with FAG spherical roller bearings, seals and grease filling to form bearing units for very demanding operating conditions, *Figure 27 to Figure 38*.

- ① Locating bearing BND...Z-Y-AF-S
- ② Non-locating bearing BND...Z-Y-AL-S

Figure 27

Plummer block housing BND for bearing with cylindrical bore (labyrinth seal), design A

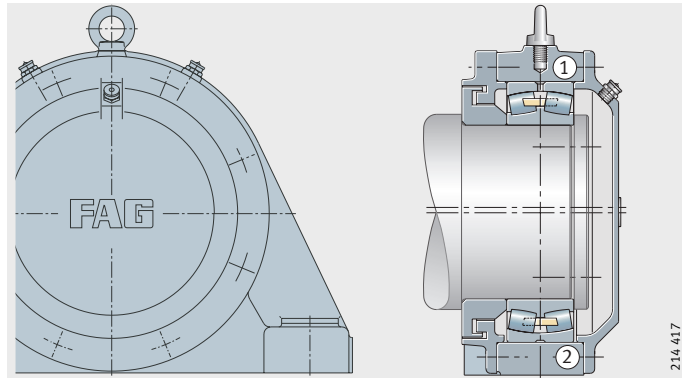

- ① Locating bearing BND...Z-Y-BF-S
- ② Non-locating bearing BND...Z-Y-BL-S

Figure 28

Plummer block housing BND for bearing with cylindrical bore (labyrinth seal), design B

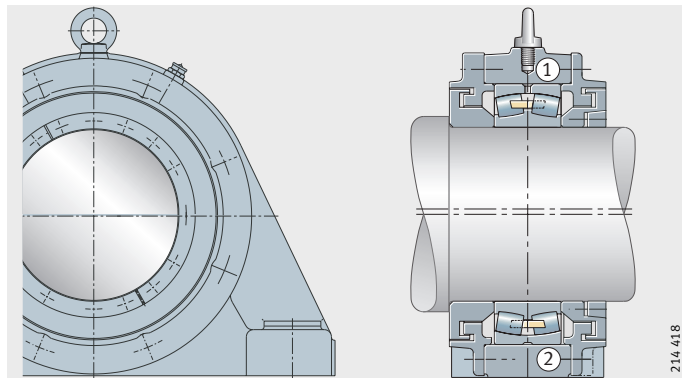

- ① Locating bearing BND...Z-T-AF-S
- ② Non-locating bearing BND...Z-T-AL-S

Figure 29

Plummer block housing BND for bearing with cylindrical bore (Taconite seal), design A

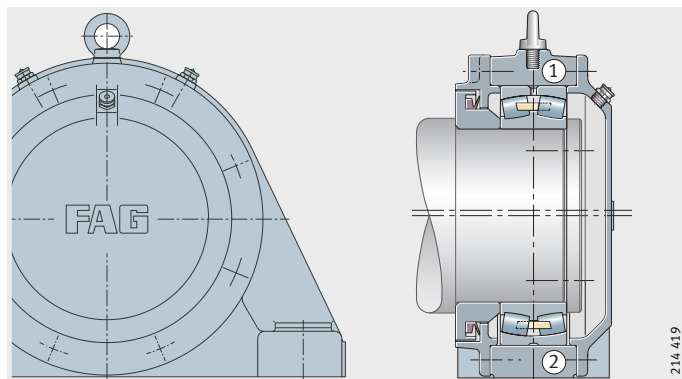

Bearing housings

- ① Locating bearing BND..-Z-T-BF-S
- ② Non-locating bearing BND..-Z-T-BL-S

Figure 30

Plummer block housing BND for bearing with cylindrical bore (Taconite seal), design B

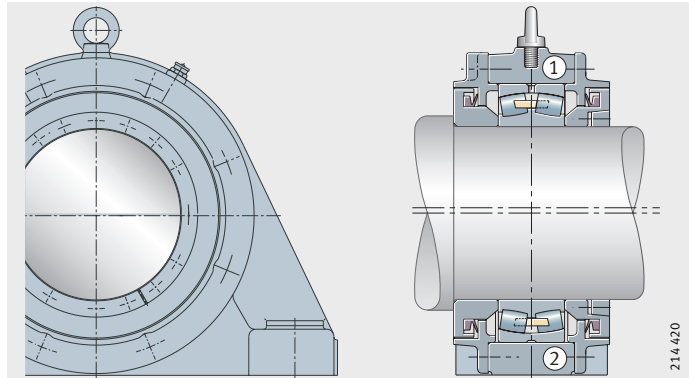

- ① Locating bearing BND..-H-W-Y-AF-S
- ② Non-locating bearing BND..-H-W-Y-AL-S

Figure 31

Plummer block housing BND for bearing with tapered bore and adapter sleeve (labyrinth seal), design A

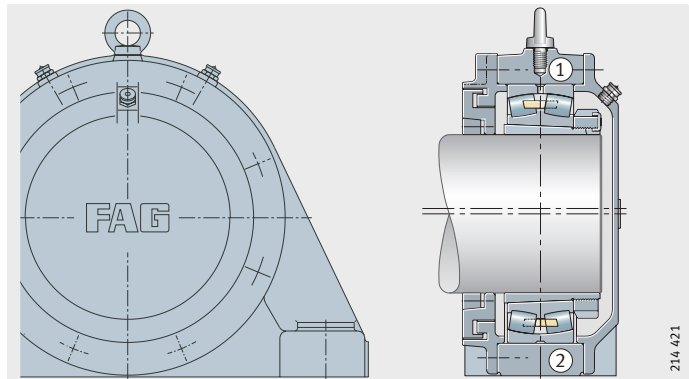

- ① Locating bearing BND..-H-W-Y-BF-S
- ② Non-locating bearing BND..-H-W-Y-BL-S

Figure 32

Plummer block housing BND for bearing with tapered bore and adapter sleeve (labyrinth seal), design B

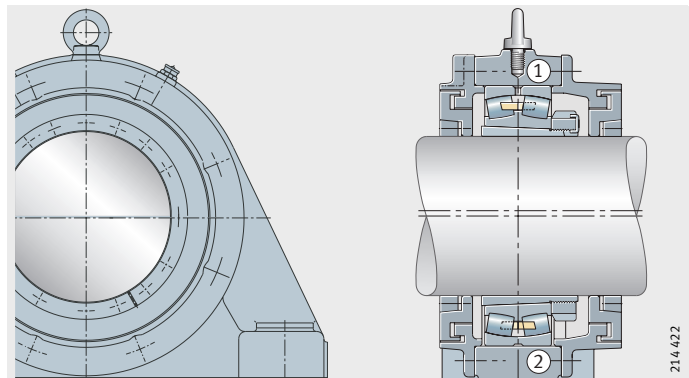

- ① Locating bearing BND..-H-W-T-AF-S
- ② Non-locating bearing BND..-H-W-T-AL-S

Figure 33

Plummer block housing BND for bearing with tapered bore and adapter sleeve (Taconite seal), design A

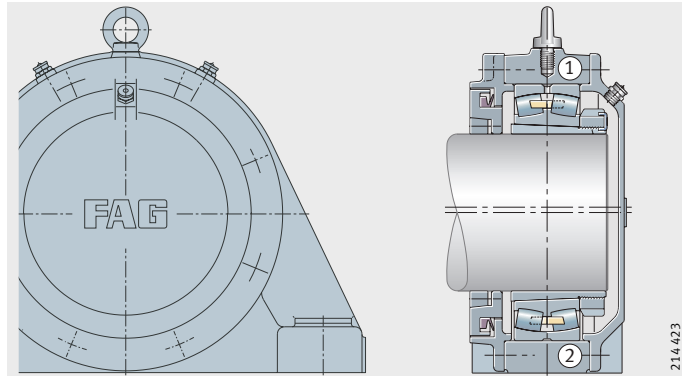

- ① Locating bearing BND..-H-W-T-BF-S
- ② Non-locating bearing BND..-H-W-T-BL-S

Figure 34

Plummer block housing BND for bearing with tapered bore and adapter sleeve (Taconite seal), design B

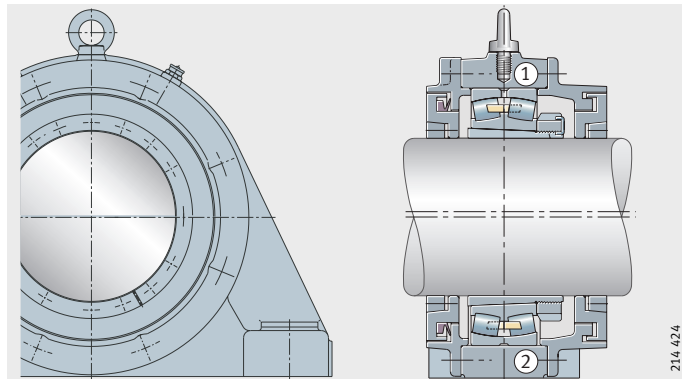

- ① Locating bearing BND..-H-C-Y-AF-S
- ② Non-locating bearing BND..-H-C-Y-AL-S

Figure 35

Plummer block housing BND for bearing with tapered bore and adapter sleeve and for shaft with abutment shoulder (labyrinth seal), design A

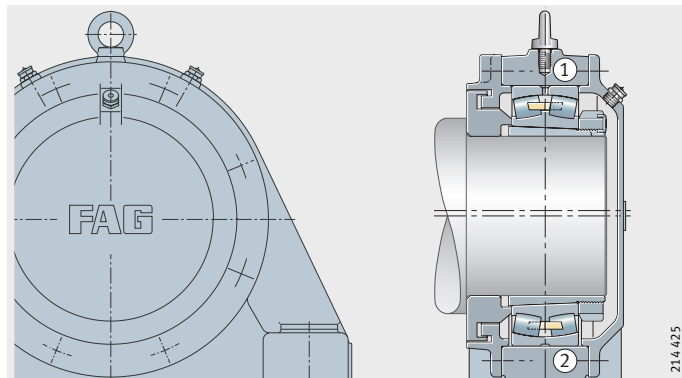

Bearing housings

- ① Locating bearing BND...-H-C-Y-BF-S
- ② Non-locating bearing BND...-H-C-Y-BL-S

Figure 36

Plummer block housing BND for bearing with tapered bore and adapter sleeve and for shaft with abutment shoulder (labyrinth seal), design B

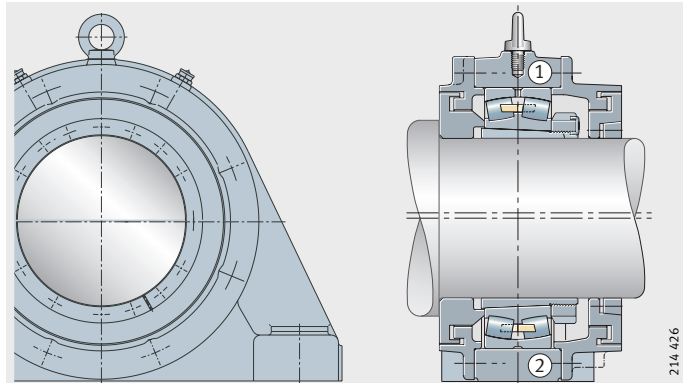

- ① Locating bearing BND...-H-C-T-AF-S
- ② Non-locating bearing BND...-H-C-T-AL-S

Figure 37

Plummer block housing BND for bearing with tapered bore and adapter sleeve and for shaft with abutment shoulder (Taconite seal), design A

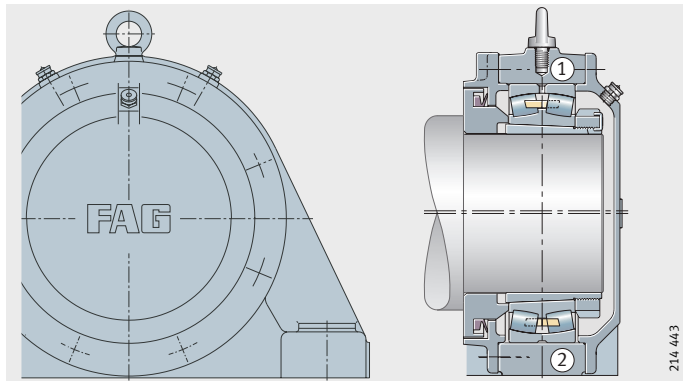

- ① Locating bearing BND...-H-C-T-BF-S
- ② Non-locating bearing BND...-H-C-T-BL-S

Figure 38

Plummer block housing BND for bearing with tapered bore and adapter sleeve and for shaft with abutment shoulder (Taconite seal), design B

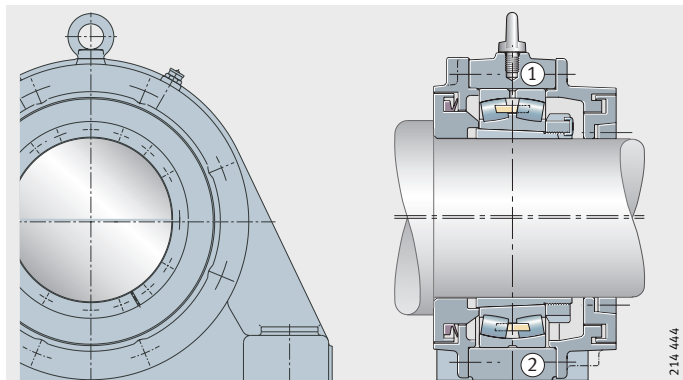

Unsplit housings of series BND, originally developed for belt conveyors, can also be beneficially used in materials processing, for example in hard crushers, sugar cane mill drives and rotor shafts in wind turbines.

The dimensions of housings BND are matched to spherical roller bearings of series 222, 230, 231 and 232.

In housings BND of design A for the bearing arrangements of shaft ends, one side is closed by a cover. Design B is intended for continuous shafts.

The housing body, labyrinth rings and cover are unsplit. The labyrinth rings are located by means of split tapered rings made from laminated fabric material. The labyrinth gaps are dimensioned so that the shafts can undergo deflection of approx. 0,5° in both directions without the labyrinths touching the bore.

Material The standard material for the housing bodies is cast steel (suffix S). If required, housing bodies made from spheroidal graphite cast iron (suffix D) are available.

Bearing seat and fitting of bearings The bearing seat in the housing is machined to H7. The housings are supplied as a locating bearing design or non-locating bearing design. In the locating bearing, the bearing is clamped between the housing covers. In the non-locating bearing, the bearing can align itself axially, since the covers have shorter centring collars. Housings BND can accommodate rolling bearings with a cylindrical bore that are seated directly on a stepped shaft. We recommend machining the shaft to m6 for these bearings. Shaft seats for bearings with a tapered bore seated on adapter sleeves should be machined to h8.

Seals Plummer block housings BND are sealed on one side (design A) or on both sides (design B) by labyrinths (suffix Y). If required, Taconite seals (suffix T) are available with a V ring integrated in the labyrinth (these must be relubricated separately).

Load carrying capacity Guide values for the rupture load of housings BND: see Housings BND, page 1219. When determining the permissible load, a safety factor of 6 should be applied to the housing rupture load.

Caution! Housings BND should not be subjected to an axial load greater than 20% of the housing rupture load F_{180° . For load directions between 55° and 120° and axial load, we recommend that the housings should be secured in the load direction by means of stops or dowels. The ring bolts in the upper section of the housing must not be loaded to a value greater than the mass of the housing including the bearing.



Bearing housings

Lubrication Housings BND are designed for grease lubrication. Suitable lubricants are lithium soap greases of consistency 2 and 3, for example rolling bearing grease MULTI3 for low loads and MULTITOP and LOAD400 for high and very high loads. The housings have button head lubrication nipples with a head diameter standardised to DIN 3 404 of 22 mm. The grease is fed uniformly to both rows of rollers via the circumferential slot and three lubrication holes in the outer ring of the spherical roller bearings.

In initial lubrication, the cavities in the bearing, the housing and the labyrinths are completely filled with grease. Recommended grease quantities: see table.

The relubrication intervals should be matched to the environmental conditions. The bearings should be relubricated after an interval of no more than four weeks.

For relubrication, we recommend approx. 10% of the grease used for initial filling. For machinery operating in highly contaminated environments, relubrication should be carried out daily with small quantities.

Recommended grease quantity for initial filling of housings BND (housing cavities and bearing completely filled)

Bearing bore mm	Grease quantity for initial filling	
	BND31, BND22, BND32 ≈g	BND30 ≈g
65	700	–
75	800	–
90	900	–
100	950	–
110	1 000	–
120	1 100	500
130	1 250	600
140	1 400	700
150	1 700	800
160	1 900	900
170	2 200	1 000
180	2 500	1 200
190	6 000	1 300
200	3 600	1 600
220	4 200	1 900
240	5 000	2 100
260	6 000	2 500
280	7 000	3 000
300	8 000	3 500
320	9 000	4 100
340	10 500	4 800
360	12 000	5 500
380	13 000	6 200
400	14 500	7 000
420	16 000	8 000

Flanged housings
Flanged housings F112

These housings are fitted with self-aligning ball bearings with an extended inner ring of series 112, *Figure 39* to *Figure 41*.

Figure 39
 Flanged housing for self-aligning ball bearings with extended inner ring F11204 to F11206

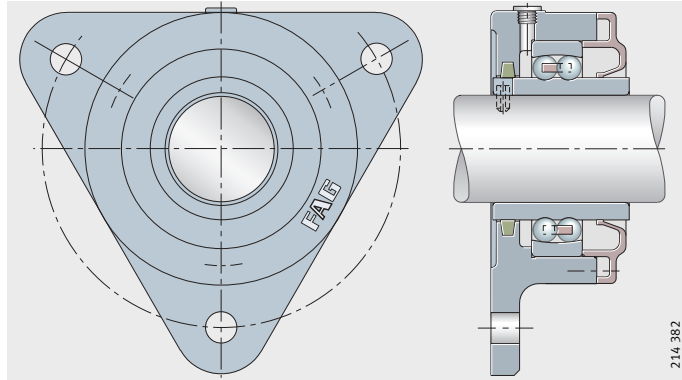

Figure 40
 Flanged housing for self-aligning ball bearings with extended inner ring F11207 to F11208

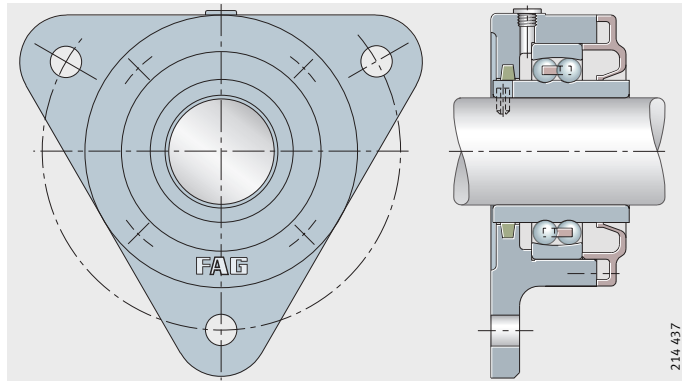
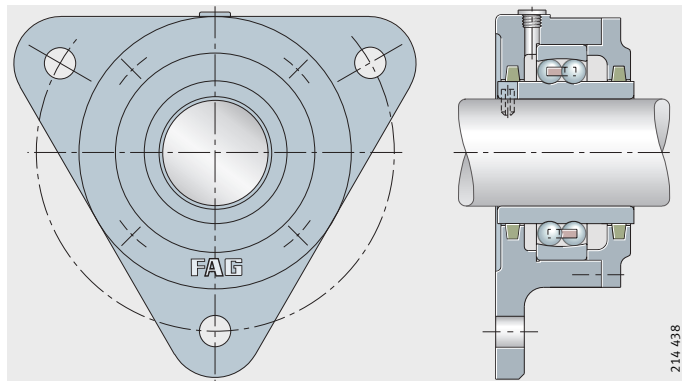

Figure 41
 Flanged housing for self-aligning ball bearings with extended inner ring F11209 and F11210



Flanged housings F11204 to F11208 have, on the side facing away from the housing flange, a polyamide cover designed as a seal. The larger housings have covers made from flake graphite cast iron and felt seals. Felt seals allow shaft misalignment of up to 0,5° in both directions.

All flanged housings have a threaded hole M10×1 that is closed off by a plastic plug until relubrication is to be carried out.

The housing material is flake graphite cast iron.

Bearing housings

Flanged housings F5

Flanged housings for bearings with a tapered bore and adapter sleeve, *Figure 42 to Figure 45.*

- ① Locating bearing (A, WA)
- ② Non-locating bearing (A, WA)

Figure 42

Flanged housing for bearings with tapered bore and adapter sleeve F505, F506, F508, design A

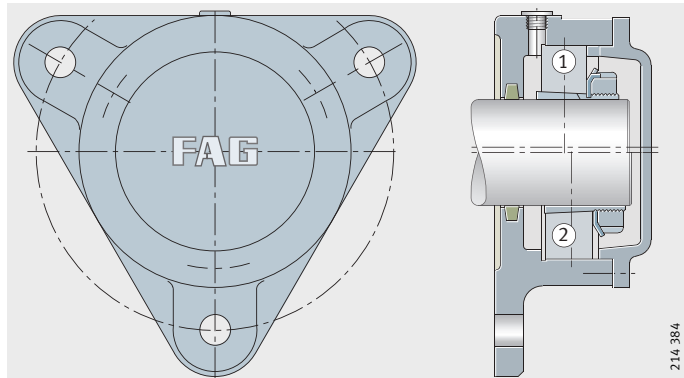

- ① Locating bearing (B, WB)
- ② Non-locating bearing (B, WB)

Figure 43

Flanged housing for bearings with tapered bore and adapter sleeve F507, F509 to F513, design B

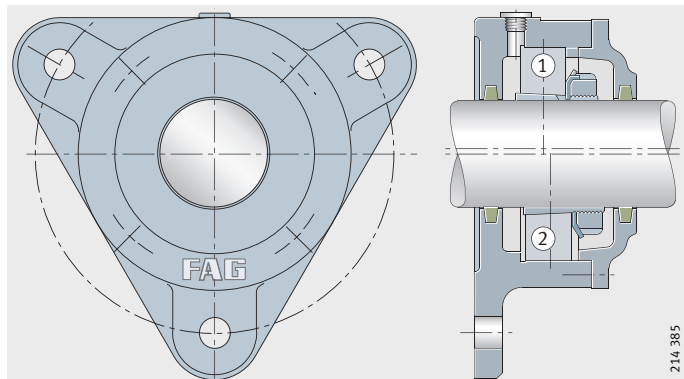

- ① Locating bearing (A, WA)
- ② Non-locating bearing (A, WA)

Figure 44

Flanged housing for bearings with tapered bore and adapter sleeve F515 to F522, design A

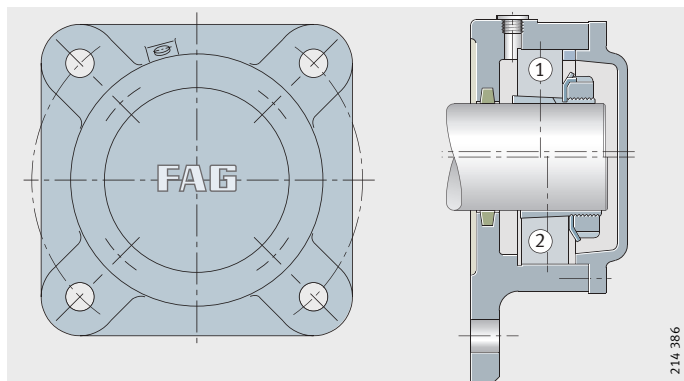

- ① Locating bearing (B, WB)
- ② Non-locating bearing (B, WB)

Figure 45
 Flanged housing for bearings with tapered bore and adapter sleeve F515 to F522, design B

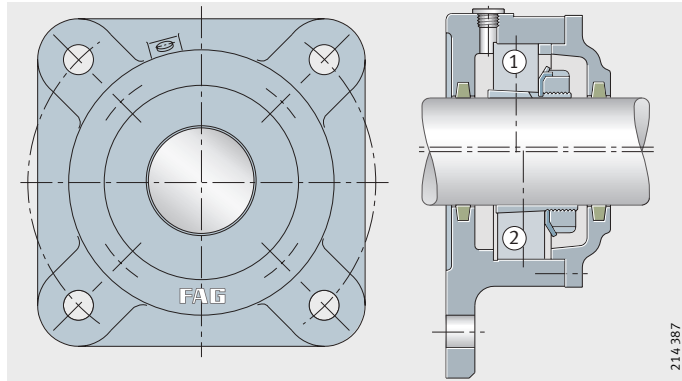

These flanged housings are suitable for self-aligning ball bearings, barrel roller bearings and spherical roller bearings with a tapered bore that are located on the shaft using adapter sleeves. The housings are available with one side closed off (design A) or – for continuous shafts – open on both sides (design B). Felt strips are used for sealing. Felt seals allow shaft misalignment of up to 0,5° in both directions.

The housings are designed as non-locating bearing housings. Locating bearing arrangements can be achieved by the insertion of locating rings. The number of rings required is indicated in the tables. Two rings are inserted on both sides of the bearing, a single ring is inserted on the side with the adapter sleeve nut. Locating rings must be ordered separately.

The housing material is flake graphite cast iron (suffix L).

Design and safety guidelines

Load carrying capacity of split plummer block housings

The permissible load on the housing is dependent on the strength of the housing and connecting screws, the load carrying capacity of the bearing and on the load direction. Guide values for the rupture load of the housings and the maximum load carrying capacity of the screws connecting the upper and lower sections of the housing are given on the following pages.

When determining the permissible load, safety factors must be applied. For general machine building, a safety factor of 6 relative to the housing rupture load is normally applied.

The values in the tables are valid if the mounting surface of the mating parts is in accordance with DIN ISO 2 768-H.

A precondition for supporting loads is that the housing base surface is completely and rigidly supported.

Caution! Housings SNV and SD31 must not be subjected to axial loads greater than $\frac{2}{3}$ of the housing rupture load F_{180° , housings S30 must not be subjected to axial loads greater than 35% of F_{180° . For load directions between 55° and 120° and axial load, we recommend that the housings should be secured in the load direction by means of stops or dowels.

The ring bolts in the upper section of the housing must not be loaded to a value greater than the mass of the housing including the bearing.



Bearing housings

Housings SNV

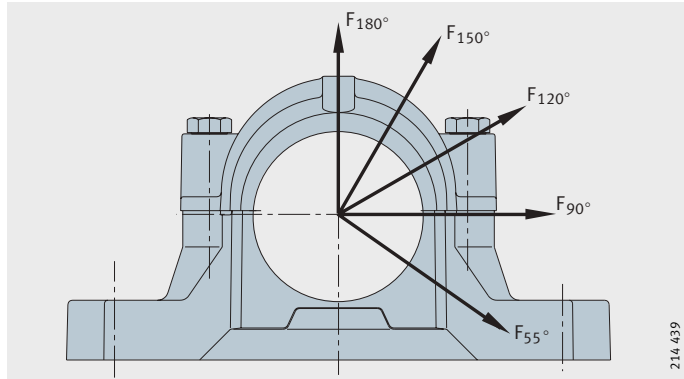

Figure 46
 Guide values for the rupture load of housings SNV and the maximum load carrying capacity of the connecting screws (for tightening torques, see also page 1221)

Housing Designation	Housing rupture load in load direction F Housing made from flake graphite cast iron					Connecting screws			
	55° kN	90°	120°	150°	180°	Thread to DIN 13	Maximum load carrying capacity of both screws with contact between parting surfaces in load direction		
						Material 8.8	120° kN	150°	180°
SNV052	160	95	70	60	80	M10	60	35	30
SNV062	170	100	80	65	85	M10	60	35	30
SNV072	190	110	85	80	95	M10	60	35	30
SNV080	210	130	95	85	105	M10	60	35	30
SNV085	225	140	100	90	120	M10	60	35	30
SNV090	265	160	120	105	130	M10	60	35	30
SNV100	280	170	125	120	140	M12	80	45	40
SNV110	300	180	130	125	150	M12	80	45	40
SNV120	335	200	150	130	170	M12	80	45	40
SNV125	335	200	150	130	170	M12	80	45	40
SNV130	400	250	180	150	200	M12	80	45	40
SNV140	425	265	190	170	210	M12	80	45	40
SNV150	475	280	200	180	235	M12	80	45	40
SNV160	530	335	250	210	265	M16	180	100	90
SNV170	560	355	265	225	280	M16	180	100	90
SNV180	630	375	280	250	300	M20	260	150	130
SNV190	630	375	280	250	300	M20	260	150	130
SNV200	670	400	315	280	335	M20	260	150	130
SNV215	800	450	355	315	400	M20	260	150	130
SNV230	900	530	400	355	450	M24	360	210	180
SNV240	1000	600	450	400	500	M24	360	210	180
SNV250	1060	630	475	425	530	M24	360	210	180
SNV260	1180	710	530	475	600	M24	360	210	180
SNV270	1180	710	530	475	600	M24	360	210	180
SNV280	1320	750	600	530	630	M24	360	210	180
SNV290	1400	850	630	560	710	M24	360	210	180
SNV300	1500	900	670	600	750	M24	360	210	180
SNV320	1700	1000	750	670	850	M24	360	210	180
SNV340	1900	1120	850	750	950	M30	640	370	320

Housings S30

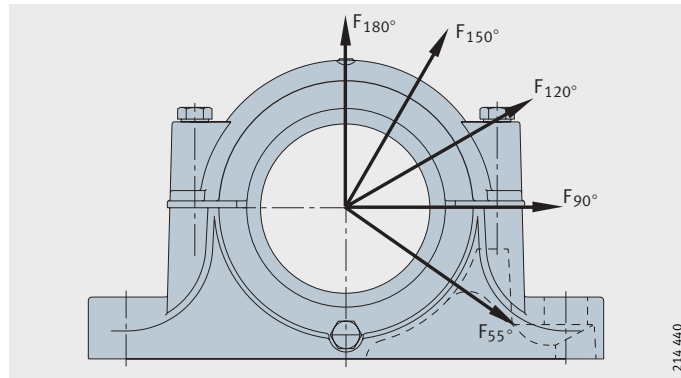

Figure 47
Guide values for the rupture load of housings S30 and the maximum load carrying capacity of the connecting screws (for tightening torques, see also page 1221)

Housing Designation	Housing rupture load in load direction F Housing made from flake graphite cast iron					Connecting screws			
						Thread to DIN 13	Maximum load carrying capacity of both screws with contact between parting surfaces in load direction		
	55° kN	90°	120°	150°	180°	Material 8.8	120° kN	150°	180°
S3024	540	320	245	215	270	M20	260	150	130
S3026	620	370	280	250	310	M20	260	150	130
S3028	700	420	315	280	350	M20	260	150	130
S3030	780	470	350	310	390	M20	260	150	130
S3032	860	520	390	345	430	M20	260	150	130
S3034	1 000	600	450	400	500	M24	360	210	180
S3036	1 160	700	520	465	580	M24	360	210	180
S3038	1 300	780	585	520	650	M24	360	210	180
S3040	1 500	890	665	590	740	M24	360	210	180
S3044	1 700	1 020	765	680	850	M30	640	370	320
S3048	1 900	1 130	845	750	940	M30	640	370	320
S3052	2 200	1 320	990	880	1 100	M36	800	460	400
S3056	2 500	1 500	1 120	1 000	1 300	M36	800	460	400
S3060	2 700	1 620	1 215	1 080	1 350	M36	800	460	400
S3064	2 900	1 740	1 305	1 160	1 450	M36	800	460	400
S3068	3 200	1 920	1 440	1 280	1 600	M36	800	460	400
S3072	3 500	2 100	1 575	1 400	1 750	M36	800	460	400
S3076	3 900	2 340	1 755	1 560	1 950	M36	800	460	400
S3080	4 300	2 580	1 935	1 720	2 150	M36	800	460	400
S3084	4 900	2 940	2 205	1 960	2 450	M36	800	460	400
S3088	5 300	3 180	2 385	2 120	2 650	M36	800	460	400
S3092	6 100	3 660	2 745	2 440	3 050	M48	1 340	770	670
S3096	7 000	4 200	3 150	2 800	3 500	M48	1 340	770	670



Bearing housings

Housings SD31

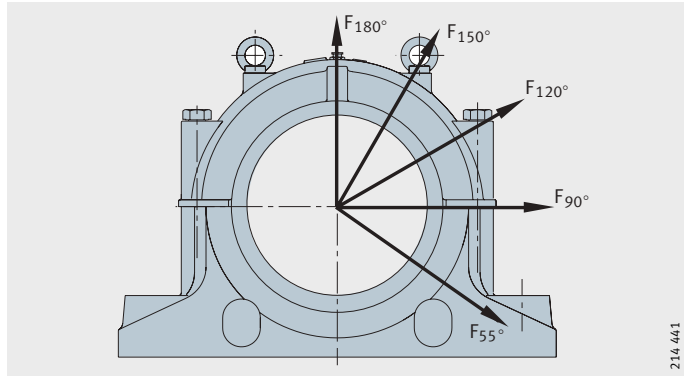

Figure 48
Guide values for the rupture load of housings SD31 and the maximum load carrying capacity of the connecting screws (for tightening torques, see also page 1221)

Housing Designation	Housing rupture load in load direction F Housing made from flake graphite cast iron					Connecting screws			
						Thread to DIN 13	Maximum load carrying capacity of the four screws with contact between parting surfaces in load direction		
	55° kN	90°	120°	150°	180°	Material 8.8	120° kN	150°	180°
SD3134	2 600	1 100	1 000	940	1 050	M20	520	300	260
SD3136	2 750	1 200	1 050	1 000	1 100	M20	520	300	260
SD3138	3 000	1 350	1 150	1 100	1 200	M20	520	300	260
SD3140	4 000	1 700	1 450	1 400	1 600	M24	720	420	360
SD3144	4 250	1 900	1 600	1 500	1 700	M24	720	420	360
SD3148	4 600	2 300	1 800	1 600	1 850	M24	720	420	360
SD3152	5 500	2 550	2 150	2 050	2 200	M30	1 280	740	640
SD3156	6 600	3 100	2 400	2 250	2 650	M30	1 280	740	640
SD3160	7 750	3 400	2 900	2 800	3 100	M30	1 280	740	640
SD3164	8 100	3 650	3 100	3 000	3 250	M30	1 280	740	640
SD3168	8 850	4 000	3 200	3 100	3 550	M30	1 280	740	640
SD3172	9 750	4 500	3 350	3 250	3 900	M30	1 280	740	640
SD3176	10 300	4 800	3 400	3 300	4 150	M30	1 280	740	640
SD3180	10 700	5 000	3 500	3 400	4 300	M36	1 600	920	800
SD3184	12 000	5 800	4 000	3 750	4 800	M36	1 600	920	800
SD3188	12 400	5 950	4 450	3 950	4 950	M36	1 600	920	800
SD3192	13 300	6 350	4 750	4 250	5 300	M36	1 600	920	800
SD3196	14 300	6 850	5 150	4 550	5 700	M42	2 060	1 180	1 030

Load carrying capacity of unsplit plummer block housings

The permissible load on the housing is dependent on the strength of the housing, the load carrying capacity of the bearing and on the load direction. Guide values for the rupture load of the housings are indicated in the following table.

When determining the permissible load, safety factors must be applied. For general machine building, a safety factor of 6 relative to the housing rupture load is normally applied.

The values in the tables are valid if the mounting surface of the mating parts is in accordance with DIN ISO 2 768-H.

A precondition for supporting loads is that the housing base surface is completely and rigidly supported.

Housings BND

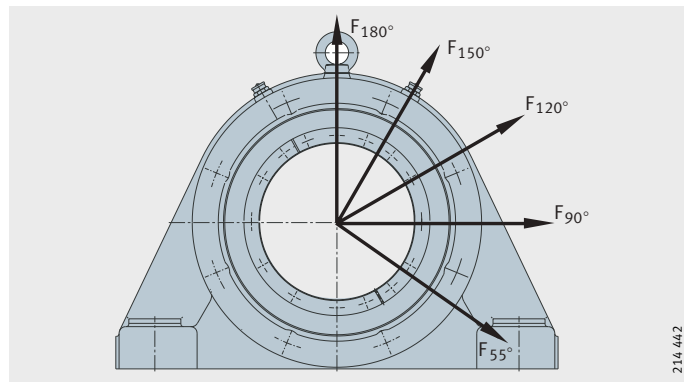

Figure 49
Guide values for the rupture load of housings BND made from cast steel and spheroidal graphite cast iron

Housing Designation				Housing rupture load in load direction F				
				55°	90°	120°	150°	180°
BND2213	–	–	–	665	530	440	350	440
BND2215	–	–	–	880	705	580	465	580
BND2218	–	–	–	1 125	900	745	595	745
BND2220	BND3024	–	–	1 325	1 070	1 020	815	1 020
–	–	BND3122	–	1 900	1 530	1 685	1 345	1 685
BND2222	BND3026	–	–	1 580	1 275	1 120	920	1 120
–	–	BND3124	BND3222	1 875	1 500	1 685	1 345	1 685
BND2224	BND3028	–	–	1 785	1 430	1 225	1 020	1 225
–	–	BND3126	BND3224	2 020	1 610	1 735	1 385	1 735
BND2226	BND3030	–	–	2 040	1 630	2 140	1 735	2 140
–	BND3032	–	–	2 295	1 835	2 245	1 835	2 245
–	–	BND3128	BND3226	2 295	1 835	1 735	1 385	1 735
BND2228	BND3034	–	–	2 755	2 195	2 245	1 835	2 245
–	–	BND3130	BND3228	2 755	2 195	1 785	1 430	1 785
BND2230	BND3036	–	–	3 060	2 450	2 245	1 835	2 245
–	–	BND3132	BND3230	3 110	2 500	1 835	1 470	1 835
BND2232	BND3038	–	–	3 365	2 705	2 450	1 940	2 450
–	–	BND3134	BND3232	3 570	2 855	1 940	1 550	1 940
BND2234	BND3040	–	–	3 925	3 110	3 060	2 450	3 060
–	–	BND3136	BND3234	4 285	3 415	2 040	1 630	2 040
BND2236	–	–	–	4 435	3 570	3 470	2 755	3 470



Bearing housings

Housing Designation				Housing rupture load in load direction F				
				55°	90°	120°	150°	180°
				kN				
BND2238	BND3044	–	–	4 435	3 570	3 470	2 755	3 470
–	–	BND3138	BND3236	4 590	3 725	2 140	1 715	2 140
–	–	BND3140	BND3238	5 610	4 540	2 295	1 835	2 295
BND2240	BND3048	–	–	5 050	4 030	4 895	3 875	4 895
–	–	BND3144	BND3240	6 120	4 935	2 550	2 040	2 550
BND2244	BND3052	–	–	5 660	4 540	5 000	3 980	5 000
–	BND3056	–	–	6 580	5 255	6 120	4 895	6 120
–	–	BND3148	BND3244	6 835	5 510	3 060	2 450	3 060
BND2248	BND3060	–	–	7 295	5 815	6 325	5 100	6 325
–	–	BND3152	BND3248	7 650	6 170	3 570	2 855	3 570
BND2252	BND3064	–	–	8 000	6 425	6 835	5 400	6 835
–	–	BND3156	BND3252	9 385	7 550	4 180	3 365	4 180
BND2256	BND3068	–	–	8 825	7 040	6 835	5 400	6 835
–	–	BND3160	BND3256	10 200	8 260	4 490	3 570	4 490
BND2260	BND3072	–	–	9 640	7 700	8 160	6 530	8 160
–	BND3076	–	–	10 810	8 670	8 365	8 770	8 365
–	–	BND3164	BND3260	11 935	9 535	5 100	4 080	5 100
BND2264	BND3080	–	–	12 035	9 690	9 080	7 240	9 080
–	–	BND3168	BND3264	14 280	11 375	5 815	4 590	5 815
BND2268	BND3084	–	–	13 360	10 760	9 280	7 345	9 280
–	–	BND3172	–	14 485	11 630	6 630	5 300	6 630
BND2272	–	–	–	15 700	12 570	10 370	8 325	10 370
–	–	BND3176	BND3268	16 320	13 055	6 630	5 300	6 630
BND2276	–	–	–	16 600	13 280	10 960	8 800	10 960
–	–	BND3180	BND3272	17 850	14 280	7 345	5 815	7 345
BND2280	–	–	–	19 750	15 800	13 030	10 470	13 030
–	–	–	BND3276	18 870	15 050	8 160	6 530	8 160
–	–	BND3184	–	19 380	15 600	8 160	6 530	8 160
BND2284	–	–	–	21 540	17 240	14 220	11 420	14 220
–	–	–	BND3280	22 440	17 950	9 280	7 445	9 280
–	–	–	BND3284	24 480	19 380	10 710	8 570	10 710

Tightening torques

The tightening torques in the following table are maximum values for metric coarse-pitch threads to DIN 13-13 and head contact dimensions to DIN 912, 931, 933, 934, 6 912, 7 984 and 7 990.

They are valid with 90% utilisation of the yield stress of the material of 8.8 screws and a friction factor of 0,14. We recommend that the screws should be tightened to 70% of these values. Housings are not supplied together with screws for the housing base.

Maximum tightening torques for screws with metric thread to DIN 13-13

Nominal screw size	Tightening torque Nm
M6	10,4
M8	25
M10	51
M12	87
M16	215
M20	430
M24	740
M30	1 450
M36	2 600
M42	4 000
M45	4 950
M48	6 000
M56	9 650
M64	14 400



Bearing housings

Accessories Grease valves

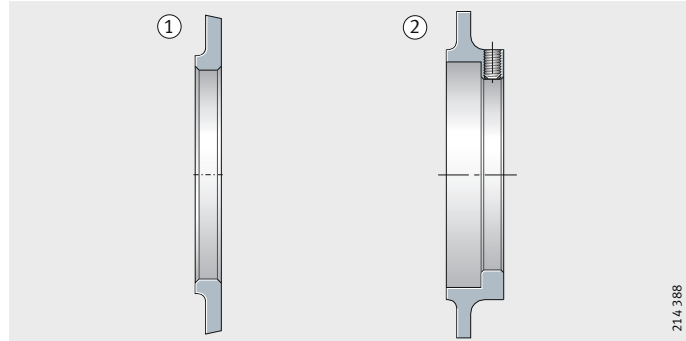

- ① RSV2, RSV3
- ② RSV5, RSV6

Figure 50
Grease valves RSV

214 388

Locating rings

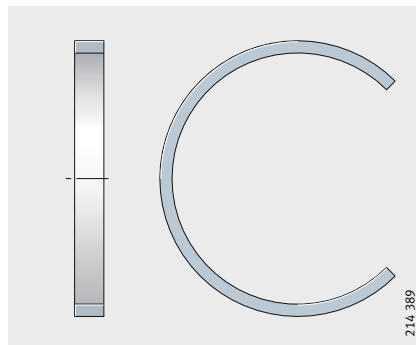

Figure 51
Locating ring FRM

214 389

Seals

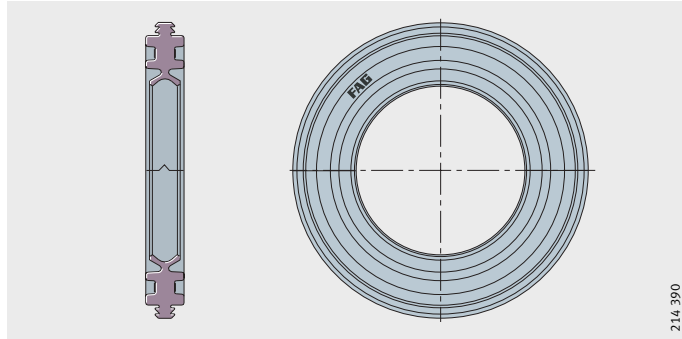

Figure 52
Double lip seal DH

214.390

- ① V ring seal DHV
- ② Felt seal FSV
- ③ Felt strip FJST

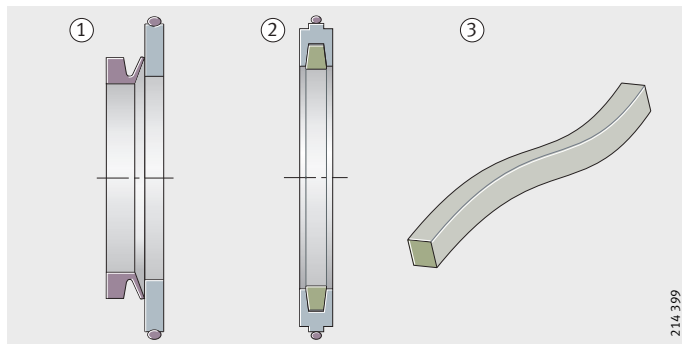

Figure 53
Seals DHV, FSV and FJST

214.399

- ① TSV
- ② TCV

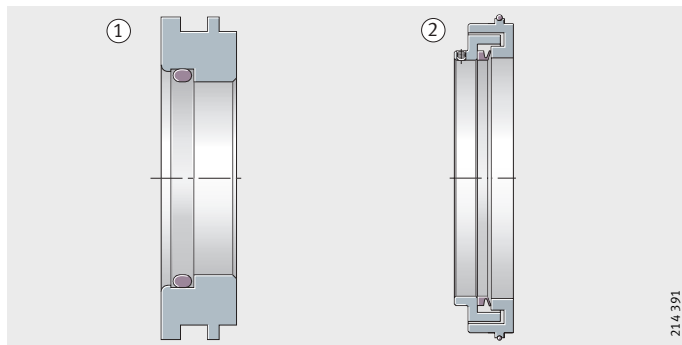

Figure 54
Seals TSV and TCV

214.391



Bearing housings

Covers

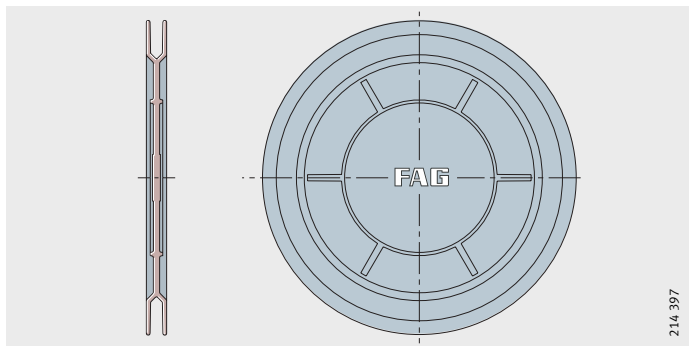
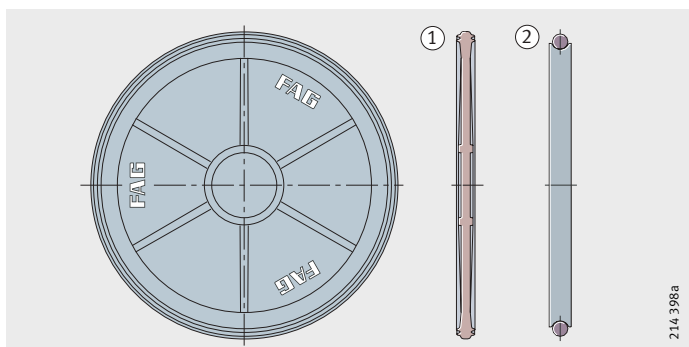

Figure 55
Cover DK

214 397



- ① Cover DKV
- ② Cover DKVT

Figure 56
Covers DKV and DKVT

214 398a



Plummer block housings

SNV, split
For bearings with tapered bore and adapter sleeve

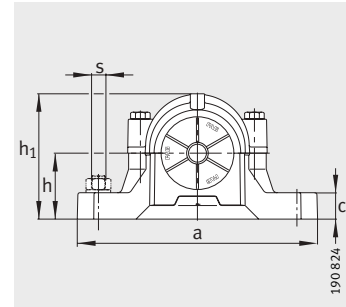
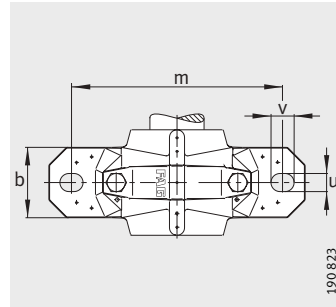

- ① Locating bearing
- ② Non-locating bearing

Dimension table · Dimensions in mm								
Designation								
Housing	Bearing	Adapter sleeve	Locating ring 2 pieces	Double lip seal	Labyrinth ring with round cord	Felt seal	V ring seal	Taconite seal
SNV052-L	1205-K-TVH-C3	H205X012	FRM52/6	DH505X012	TSV505X012	FSV505X012	DHV505X012	-
SNV052-L	20205-K-TVP-C3	H205X012	FRM52/6	DH505X012	TSV505X012	FSV505X012	DHV505X012	-
SNV052-L	2205-K-TVH-C3	H305X012	FRM52/4,5	DH505X012	TSV505X012	FSV505X012	DHV505X012	-
SNV052-L	22205-E1-K	H305X012	FRM52/4,5	DH505X012	TSV505X012	FSV505X012	DHV505X012	-
SNV062-L	1305-K-TVH-C3	H305X012	FRM62/6,5	DH605X012	TSV605X012	FSV605X012	DHV605X012	-
SNV062-L	2305-K-TVH-C3	H2305X012	FRM62/3	DH605X012	TSV605X012	FSV605X012	DHV605X012	-
SNV052-L	1205-K-TVH-C3	H205	FRM52/6	DH505	TSV505	FSV505	DHV505	-
SNV052-L	20205-K-TVP-C3	H205	FRM52/6	DH505	TSV505	FSV505	DHV505	-
SNV052-L	2205-K-TVH-C3	H305	FRM52/4,5	DH505	TSV505	FSV505	DHV505	-
SNV052-L	22205-E1-K	H305	FRM52/4,5	DH505	TSV505	FSV505	DHV505	-
SNV062-L	1305-K-TVH-C3	H305	FRM62/6,5	DH605	TSV605	FSV605	DHV605	-
SNV062-L	2305-K-TVH-C3	H2305	FRM62/3	DH605	TSV605	FSV605	DHV605	-
SNV052-L	1205-K-TVH-C3	H205X013	FRM52/6	DH505	TSV505X013	FSV505	DHV505	-
SNV052-L	20205-K-TVP-C3	H205X013	FRM52/6	DH505	TSV505X013	FSV505	DHV505	-
SNV052-L	2205-K-TVH-C3	H305X013	FRM52/4,5	DH505	TSV505X013	FSV505	DHV505	-
SNV052-L	22205-E1-K	H305X013	FRM52/4,5	DH505	TSV505X013	FSV505	DHV505	-
SNV062-L	1206-K-TVH-C3	H206X014	FRM62/7	DH506X014	TSV506X014	FSV506X014	DHV506X014	-
SNV062-L	20206-K-TVP-C3	H206X014	FRM62/7	DH506X014	TSV506X014	FSV506X014	DHV506X014	-
SNV062-L	2206-K-TVH-C3	H306X014	FRM62/5	DH506X014	TSV506X014	FSV506X014	DHV506X014	-
SNV062-L	22206-E1-K	H306X014	FRM62/5	DH506X014	TSV506X014	FSV506X014	DHV506X014	-
SNV072-L	1306-K-TVH-C3	H306X014	FRM72/7	DH606X014	TSV606X014	FSV606X014	DHV606X014	TCV606X014
SNV072-L	2306-K-TVH-C3	H2306X014	FRM72/3	DH606X014	TSV606X014	FSV606X014	DHV606X014	TCV606X014
SNV062-L	1206-K-TVH-C3	H206X015	FRM62/7	DH506X014	TSV506X015	FSV506X015	DHV506X015	-
SNV062-L	20206-K-TVP-C3	H206X015	FRM62/7	DH506X014	TSV506X015	FSV506X015	DHV506X015	-
SNV062-L	2206-K-TVH-C3	H306X015	FRM62/5	DH506X014	TSV506X015	FSV506X015	DHV506X015	-
SNV062-L	22206-E1-K	H306X015	FRM62/5	DH506X014	TSV506X015	FSV506X015	DHV506X015	-
SNV072-L	1306-K-TVH-C3	H306X015	FRM72/7	DH606X014	TSV606X015	FSV606X015	DHV606X015	TCV606X015
SNV072-L	2306-K-TVH-C3	H2306X015	FRM72/3	DH606X014	TSV606X015	FSV606X015	DHV606X015	TCV606X015

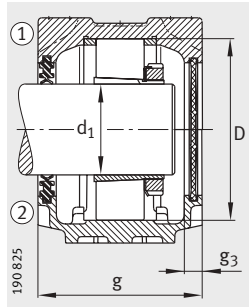

Double lip seal DH
Cover DKV

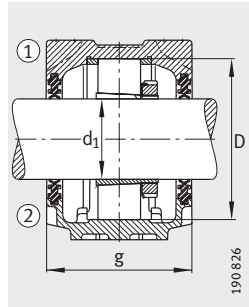

Double lip seal DH

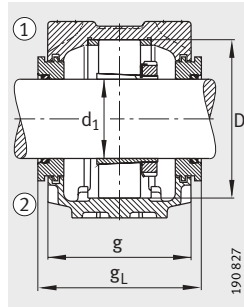

Labyrinth ring TSV

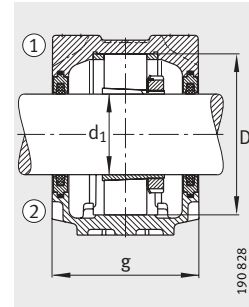

Felt seal FSV

Cover	Mass m Housing ≈kg	Dimensions																	
		d ₁		a	g	h ₁	b	c	D	g _L	g _V	g _T	g ₃	h	m	u	v	s	
		mm	inch															mm	inch
DKV052	1,3	19,05	³ / ₄	165	70	75	46	19	52	83	76	-	10,5	40	130	15	20	M12	¹ / ₂
DKV052	1,3	19,05	³ / ₄	165	70	75	46	19	52	83	76	-	10,5	40	130	15	20	M12	¹ / ₂
DKV052	1,3	19,05	³ / ₄	165	70	75	46	19	52	83	76	-	10,5	40	130	15	20	M12	¹ / ₂
DKV052	1,3	19,05	³ / ₄	165	70	75	46	19	52	83	76	-	10,5	40	130	15	20	M12	¹ / ₂
DKV062	1,9	19,05	³ / ₄	185	75	91	52	22	62	88	81	-	10,5	50	150	15	20	M12	¹ / ₂
DKV062	1,9	19,05	³ / ₄	185	75	91	52	22	62	88	81	-	10,5	50	150	15	20	M12	¹ / ₂
DKV052	1,3	20	-	165	70	75	46	19	52	83	76	-	10,5	40	130	15	20	M12	¹ / ₂
DKV052	1,3	20	-	165	70	75	46	19	52	83	76	-	10,5	40	130	15	20	M12	¹ / ₂
DKV052	1,3	20	-	165	70	75	46	19	52	83	76	-	10,5	40	130	15	20	M12	¹ / ₂
DKV052	1,3	20	-	165	70	75	46	19	52	83	76	-	10,5	40	130	15	20	M12	¹ / ₂
DKV062	1,9	20	-	185	75	91	52	22	62	88	81	-	10,5	50	150	15	20	M12	¹ / ₂
DKV062	1,9	20	-	185	75	91	52	22	62	88	81	-	10,5	50	150	15	20	M12	¹ / ₂
DKV052	1,3	20,638	¹³ / ₁₆	165	70	75	46	19	52	83	76	-	10,5	40	130	15	20	M12	¹ / ₂
DKV052	1,3	20,638	¹³ / ₁₆	165	70	75	46	19	52	83	76	-	10,5	40	130	15	20	M12	¹ / ₂
DKV052	1,3	20,638	¹³ / ₁₆	165	70	75	46	19	52	83	76	-	10,5	40	130	15	20	M12	¹ / ₂
DKV052	1,3	20,638	¹³ / ₁₆	165	70	75	46	19	52	83	76	-	10,5	40	130	15	20	M12	¹ / ₂
DKV062	1,9	22,225	⁷ / ₈	185	75	91	52	22	62	88	81	-	10,5	50	150	15	20	M12	¹ / ₂
DKV062	1,9	22,225	⁷ / ₈	185	75	91	52	22	62	88	81	-	10,5	50	150	15	20	M12	¹ / ₂
DKV062	1,9	22,225	⁷ / ₈	185	75	91	52	22	62	88	81	-	10,5	50	150	15	20	M12	¹ / ₂
DKV062	1,9	22,225	⁷ / ₈	185	75	91	52	22	62	88	81	-	10,5	50	150	15	20	M12	¹ / ₂
DKV072	2	22,225	⁷ / ₈	185	80	97	52	22	72	93	86	117	10,5	50	150	15	20	M12	¹ / ₂
DKV072	2	22,225	⁷ / ₈	185	80	97	52	22	72	93	86	117	10,5	50	150	15	20	M12	¹ / ₂
DKV062	1,9	23,813	¹⁵ / ₁₆	185	75	91	52	22	62	88	81	-	10,5	50	150	15	20	M12	¹ / ₂
DKV062	1,9	23,813	¹⁵ / ₁₆	185	75	91	52	22	62	88	81	-	10,5	50	150	15	20	M12	¹ / ₂
DKV062	1,9	23,813	¹⁵ / ₁₆	185	75	91	52	22	62	88	81	-	10,5	50	150	15	20	M12	¹ / ₂
DKV062	1,9	23,813	¹⁵ / ₁₆	185	75	91	52	22	62	88	81	-	10,5	50	150	15	20	M12	¹ / ₂
DKV072	2	23,813	¹⁵ / ₁₆	185	80	97	52	22	72	93	86	117	10,5	50	150	15	20	M12	¹ / ₂
DKV072	2	23,813	¹⁵ / ₁₆	185	80	97	52	22	72	93	86	117	10,5	50	150	15	20	M12	¹ / ₂



Plummer block housings

SNV, split
For bearings with tapered bore and adapter sleeve

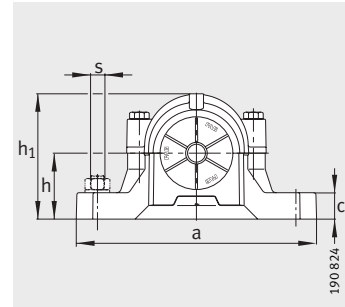
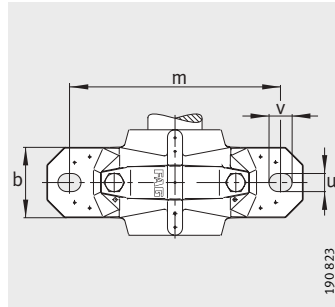

- ① Locating bearing
- ② Non-locating bearing

Dimension table (continued) - Dimensions in mm								
Designation								
Housing	Bearing	Adapter sleeve	Locating ring 2 pieces	Double lip seal	Labyrinth ring with round cord	Felt seal	V ring seal	Taconite seal
SNV062-L	1206-K-TVH-C3	H206	FRM62/7	DH506	TSV506	FSV506	DHV506	-
SNV062-L	20206-K-TVP-C3	H206	FRM62/7	DH506	TSV506	FSV506	DHV506	-
SNV062-L	2206-K-TVH-C3	H306	FRM62/5	DH506	TSV506	FSV506	DHV506	-
SNV062-L	22206-E1-K	H306	FRM62/5	DH506	TSV506	FSV506	DHV506	-
SNV072-L	1306-K-TVH-C3	H306	FRM72/7	DH606	TSV606	FSV606	DHV606	TCV606
SNV072-L	2306-K-TVH-C3	H2306	FRM72/3	DH606	TSV606	FSV606	DHV606	TCV606
SNV062-L	1206-K-TVH-C3	H206X100	FRM62/7	DH506	TSV506X100	FSV506	DHV506	-
SNV062-L	20206-K-TVP-C3	H206X100	FRM62/7	DH506	TSV506X100	FSV506	DHV506	-
SNV062-L	2206-K-TVH-C3	H306X100	FRM62/5	DH506	TSV506X100	FSV506	DHV506	-
SNV062-L	22206-E1-K	H306X100	FRM62/5	DH506	TSV506X100	FSV506	DHV506	-
SNV072-L	1306-K-TVH-C3	H306X100	FRM72/7	DH606	TSV606X100	FSV606	DHV606	TCV606
SNV072-L	2306-K-TVH-C3	H2306X100	FRM72/3	DH606	TSV606X100	FSV606	DHV606	TCV606
SNV072-L	1207-K-TVH-C3	H207X102	FRM72/8	DH507X102	TSV507X102	FSV507X102	DHV507X102	-
SNV072-L	20207-K-TVP-C3	H207X102	FRM72/8	DH507X102	TSV507X102	FSV507X102	DHV507X102	-
SNV072-L	2207-K-TVH-C3	H307X102	FRM72/5	DH507X102	TSV507X102	FSV507X102	DHV507X102	-
SNV072-L	22207-E1-K	H307X102	FRM72/5	DH507X102	TSV507X102	FSV507X102	DHV507X102	-
SNV080-L	1307-K-TVH-C3	H307X102	FRM80/9	DH607X102	TSV607X102	FSV607X102	DHV607X102	TCV607X102
SNV080-L	21307-E1-K-TVPB	H307X102	FRM80/9	DH607X102	TSV607X102	FSV607X102	DHV607X102	TCV607X102
SNV080-L	2307-K-TVH-C3	H2307X102	FRM80/4	DH607X102	TSV607X102	FSV607X102	DHV607X102	TCV607X102
SNV072-L	1207-K-TVH-C3	H207	FRM72/8	DH507	TSV507	FSV507	DHV507	-
SNV072-L	20207-K-TVP-C3	H207	FRM72/8	DH507	TSV507	FSV507	DHV507	-
SNV072-L	2207-K-TVH-C3	H307	FRM72/5	DH507	TSV507	FSV507	DHV507	-
SNV072-L	22207-E1-K	H307	FRM72/5	DH507	TSV507	FSV507	DHV507	-
SNV080-L	1307-K-TVH-C3	H307	FRM80/9	DH607	TSV607	FSV607	DHV607	TCV607
SNV080-L	21307-E1-K-TVPB	H307	FRM80/9	DH607	TSV607	FSV607	DHV607	TCV607
SNV080-L	2307-K-TVH-C3	H2307	FRM80/4	DH607	TSV607	FSV607	DHV607	TCV607
SNV072-L	1207-K-TVH-C3	H207X103	FRM72/8	DH507	TSV507	FSV507	DHV507	-
SNV072-L	20207-K-TVP-C3	H207X103	FRM72/8	DH507	TSV507	FSV507	DHV507	-
SNV072-L	2207-K-TVH-C3	H307X103	FRM72/5	DH507	TSV507	FSV507	DHV507	-
SNV072-L	22207-E1-K	H307X103	FRM72/5	DH507	TSV507	FSV507	DHV507	-
SNV080-L	1307-K-TVH-C3	H307X103	FRM80/9	DH607	TSV607	FSV607	DHV607	TCV607
SNV080-L	21307-E1-K-TVPB	H307X103	FRM80/9	DH607	TSV607	FSV607	DHV607	TCV607
SNV080-L	2307-K-TVH-C3	H2307X103	FRM80/4	DH607	TSV607	FSV607	DHV607	TCV607

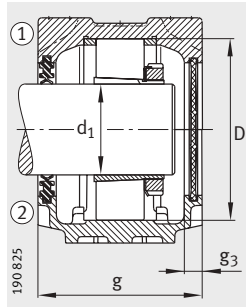

Double lip seal DH
Cover DKV

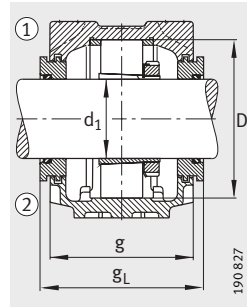

Labyrinth ring TSV

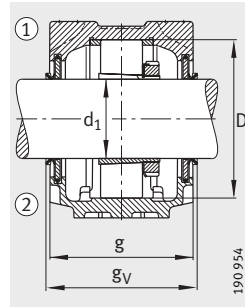

V ring seal DHV

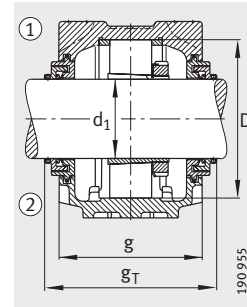

Taconite seal TCV

Cover	Mass m Housing ≈kg	Dimensions																	
		d ₁		a	g	h ₁	b	c	D	g _L	g _V	g _T	g ₃	h	m	u	v	s	
		mm	inch																mm
DKV062	1,9	25	–	185	75	91	52	22	62	88	81	–	10,5	50	150	15	20	M12	1/2
DKV062	1,9	25	–	185	75	91	52	22	62	88	81	–	10,5	50	150	15	20	M12	1/2
DKV062	1,9	25	–	185	75	91	52	22	62	88	81	–	10,5	50	150	15	20	M12	1/2
DKV062	1,9	25	–	185	75	91	52	22	62	88	81	–	10,5	50	150	15	20	M12	1/2
DKV072	2	25	–	185	80	97	52	22	72	93	86	117	10,5	50	150	15	20	M12	1/2
DKV072	2	25	–	185	80	97	52	22	72	93	86	117	10,5	50	150	15	20	M12	1/2
DKV062	1,9	25,4	1	185	75	91	52	22	62	88	81	–	10,5	50	150	15	20	M12	1/2
DKV062	1,9	25,4	1	185	75	91	52	22	62	88	81	–	10,5	50	150	15	20	M12	1/2
DKV062	1,9	25,4	1	185	75	91	52	22	62	88	81	–	10,5	50	150	15	20	M12	1/2
DKV062	1,9	25,4	1	185	75	91	52	22	62	88	81	–	10,5	50	150	15	20	M12	1/2
DKV072	2	25,4	1	185	80	97	52	22	72	93	86	117	10,5	50	150	15	20	M12	1/2
DKV072	2	25,4	1	185	80	97	52	22	72	93	86	117	10,5	50	150	15	20	M12	1/2
DKV072	2	28,575	1 1/8	185	80	97	52	22	72	93	86	–	10,5	50	150	15	20	M12	1/2
DKV072	2	28,575	1 1/8	185	80	97	52	22	72	93	86	–	10,5	50	150	15	20	M12	1/2
DKV072	2	28,575	1 1/8	185	80	97	52	22	72	93	86	–	10,5	50	150	15	20	M12	1/2
DKV072	2	28,575	1 1/8	185	80	97	52	22	72	93	86	–	10,5	50	150	15	20	M12	1/2
DKV080	2,9	28,575	1 1/8	205	85	112	60	25	80	98	91	122	10,5	60	170	15	20	M12	1/2
DKV080	2,9	28,575	1 1/8	205	85	112	60	25	80	98	91	122	10,5	60	170	15	20	M12	1/2
DKV080	2,9	28,575	1 1/8	205	85	112	60	25	80	98	91	122	10,5	60	170	15	20	M12	1/2
DKV072	2	30	–	185	80	97	52	22	72	93	86	–	10,5	50	150	15	20	M12	1/2
DKV072	2	30	–	185	80	97	52	22	72	93	86	–	10,5	50	150	15	20	M12	1/2
DKV072	2	30	–	185	80	97	52	22	72	93	86	–	10,5	50	150	15	20	M12	1/2
DKV072	2	30	–	185	80	97	52	22	72	93	86	–	10,5	50	150	15	20	M12	1/2
DKV080	2,9	30	–	205	85	112	60	25	80	98	91	122	10,5	60	170	15	20	M12	1/2
DKV080	2,9	30	–	205	85	112	60	25	80	98	91	122	10,5	60	170	15	20	M12	1/2
DKV080	2,9	30	–	205	85	112	60	25	80	98	91	122	10,5	60	170	15	20	M12	1/2
DKV072	2	30,163	1 3/16	185	80	97	52	22	72	93	86	–	10,5	50	150	15	20	M12	1/2
DKV072	2	30,163	1 3/16	185	80	97	52	22	72	93	86	–	10,5	50	150	15	20	M12	1/2
DKV072	2	30,163	1 3/16	185	80	97	52	22	72	93	86	–	10,5	50	150	15	20	M12	1/2
DKV072	2	30,163	1 3/16	185	80	97	52	22	72	93	86	–	10,5	50	150	15	20	M12	1/2
DKV080	2,9	30,163	1 3/16	205	85	112	60	25	80	98	91	122	10,5	60	170	15	20	M12	1/2
DKV080	2,9	30,163	1 3/16	205	85	112	60	25	80	98	91	122	10,5	60	170	15	20	M12	1/2
DKV080	2,9	30,163	1 3/16	205	85	112	60	25	80	98	91	122	10,5	60	170	15	20	M12	1/2



Plummer block housings

SNV, split
For bearings with tapered bore and adapter sleeve

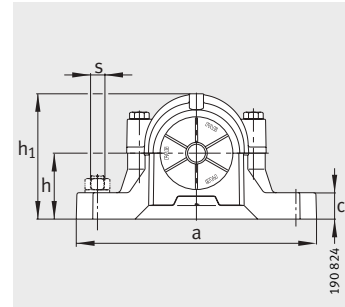
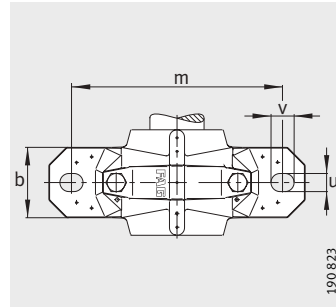

- ① Locating bearing
- ② Non-locating bearing

Dimension table (continued) · Dimensions in mm								
Designation								
Housing	Bearing	Adapter sleeve	Locating ring 2 pieces	Double lip seal	Labyrinth ring with round cord	Felt seal	V ring seal	Taconite seal
SNV080-L	1208-K-TV-C3	H208X104	FRM80/10,5	DH508X104	TSV508X104	FSV508X104	DHV508X104	TCV508X104
SNV080-L	20208-K-TVP-C3	H208X104	FRM80/10,5	DH508X104	TSV508X104	FSV508X104	DHV508X104	TCV508X104
SNV080-L	2208-K-TVH-C3	H308X104	FRM80/8	DH508X104	TSV508X104	FSV508X104	DHV508X104	TCV508X104
SNV080-L	22208-E1-K	H308X104	FRM80/8	DH508X104	TSV508X104	FSV508X104	DHV508X104	TCV508X104
SNV090-L	1308-K-TVH-C3	H308X104	FRM90/9	DH608X104	TSV608X104	FSV608X104	DHV608X104	TCV608X104
SNV090-L	21308-E1-K	H308X104	FRM90/9	DH608X104	TSV608X104	FSV608X104	DHV608X104	TCV608X104
SNV090-L	2308-K-TVH-C3	H2308X104	FRM90/4	DH608X104	TSV608X104	FSV608X104	DHV608X104	TCV608X104
SNV090-L	22308-E1-K	H2308X104	FRM90/4	DH608X104	TSV608X104	FSV608X104	DHV608X104	TCV608X104
SNV080-L	1208-K-TVH-C3	H208X105	FRM80/10,5	DH508X104	TSV508X105	FSV508X105	DHV508X105	TCV508X105
SNV080-L	20208-K-TVP-C3	H208X105	FRM80/10,5	DH508X104	TSV508X105	FSV508X105	DHV508X105	TCV508X105
SNV080-L	2208-K-TVH-C3	H308X105	FRM80/8	DH508X104	TSV508X105	FSV508X105	DHV508X105	TCV508X105
SNV080-L	22208-E1-K	H308X105	FRM80/8	DH508X104	TSV508X105	FSV508X105	DHV508X105	TCV508X105
SNV090-L	1308-K-TVH-C3	H308X105	FRM90/9	DH608X104	TSV608X105	FSV608X105	DHV608X105	TCV608X105
SNV090-L	21308-E1-K	H308X105	FRM90/9	DH608X104	TSV608X105	FSV608X105	DHV608X105	TCV608X105
SNV090-L	2308-K-TVH-C3	H2308X105	FRM90/4	DH608X104	TSV608X105	FSV608X105	DHV608X105	TCV608X105
SNV090-L	22308-E1-K	H2308X105	FRM90/4	DH608X104	TSV608X105	FSV608X105	DHV608X105	TCV608X105
SNV080-L	1208-K-TVH-C3	H208X106	FRM80/10,5	DH508	TSV508	FSV508	DHV508	TCV508
SNV080-L	20208-K-TVP-C3	H208X106	FRM80/10,5	DH508	TSV508	FSV508	DHV508	TCV508
SNV080-L	2208-K-TVH-C3	H308X106	FRM80/8	DH508	TSV508	FSV508	DHV508	TCV508
SNV080-L	22208-E1-K	H308X106	FRM80/8	DH508	TSV508	FSV508	DHV508	TCV508
SNV090-L	1308-K-TVH-C3	H308X106	FRM90/9	DH608	TSV608	FSV608	DHV608	TCV608
SNV090-L	21308-E1-K	H308X106	FRM90/9	DH608	TSV608	FSV608	DHV608	TCV608
SNV090-L	2308-K-TVH-C3	H2308X106	FRM90/4	DH608	TSV608	FSV608	DHV608	TCV608
SNV090-L	22308-E1-K	H2308X106	FRM90/4	DH608	TSV608	FSV608	DHV608	TCV608
SNV080-L	1208-K-TVH-C3	H208	FRM80/10,5	DH508	TSV508	FSV508	DHV508	TCV508
SNV080-L	20208-K-TVP-C3	H208	FRM80/10,5	DH508	TSV508	FSV508	DHV508	TCV508
SNV080-L	2208-K-TVH-C3	H308	FRM80/8	DH508	TSV508	FSV508	DHV508	TCV508
SNV080-L	22208-E1-K	H308	FRM80/8	DH508	TSV508	FSV508	DHV508	TCV508
SNV090-L	1308-K-TVH-C3	H308	FRM90/9	DH608	TSV608	FSV608	DHV608	TCV608
SNV090-L	21308-E1-K	H308	FRM90/9	DH608	TSV608	FSV608	DHV608	TCV608
SNV090-L	2308-K-TVH-C3	H2308	FRM90/4	DH608	TSV608	FSV608	DHV608	TCV608
SNV090-L	22308-E1-K	H2308	FRM90/4	DH608	TSV608	FSV608	DHV608	TCV608

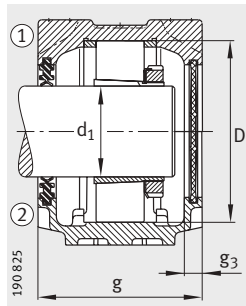

Double lip seal DH
Cover DKV

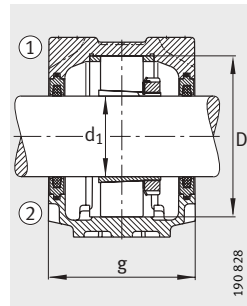

Felt seal FSV

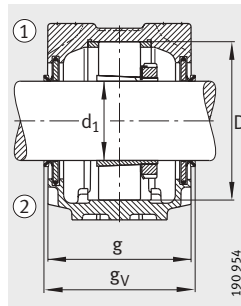

V ring seal DHV

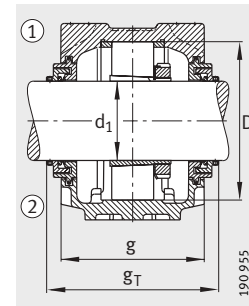

Taconite seal TCV

Cover	Mass m Housing ≈kg	Dimensions																	
		d ₁		a	g	h ₁	b	c	D	g _L	g _V	g _T	g ₃	h	m	u	v	s	
		mm	inch															mm	inch
DKV080	2,9	31,75	1¹/₄	205	85	112	60	25	80	98	91	122	10,5	60	170	15	20	M12	¹ / ₂
DKV080	2,9	31,75	1¹/₄	205	85	112	60	25	80	98	91	122	10,5	60	170	15	20	M12	¹ / ₂
DKV080	2,9	31,75	1¹/₄	205	85	112	60	25	80	98	91	122	10,5	60	170	15	20	M12	¹ / ₂
DKV080	2,9	31,75	1¹/₄	205	85	112	60	25	80	98	91	122	10,5	60	170	15	20	M12	¹ / ₂
DKV090	3,1	31,75	1¹/₄	205	100	117	60	25	90	114	104	136	12,5	60	170	15	20	M12	¹ / ₂
DKV090	3,1	31,75	1¹/₄	205	100	117	60	25	90	114	104	136	12,5	60	170	15	20	M12	¹ / ₂
DKV090	3,1	31,75	1¹/₄	205	100	117	60	25	90	114	104	136	12,5	60	170	15	20	M12	¹ / ₂
DKV090	3,1	31,75	1¹/₄	205	100	117	60	25	90	114	104	136	12,5	60	170	15	20	M12	¹ / ₂
DKV080	2,9	33,338	1⁵/₁₆	205	85	112	60	25	80	98	91	122	10,5	60	170	15	20	M12	¹ / ₂
DKV080	2,9	33,338	1⁵/₁₆	205	85	112	60	25	80	98	91	122	10,5	60	170	15	20	M12	¹ / ₂
DKV080	2,9	33,338	1⁵/₁₆	205	85	112	60	25	80	98	91	122	10,5	60	170	15	20	M12	¹ / ₂
DKV080	2,9	33,338	1⁵/₁₆	205	85	112	60	25	80	98	91	122	10,5	60	170	15	20	M12	¹ / ₂
DKV090	3,1	33,338	1⁵/₁₆	205	100	117	60	25	90	114	104	136	12,5	60	170	15	20	M12	¹ / ₂
DKV090	3,1	33,338	1⁵/₁₆	205	100	117	60	25	90	114	104	136	12,5	60	170	15	20	M12	¹ / ₂
DKV090	3,1	33,338	1⁵/₁₆	205	100	117	60	25	90	114	104	136	12,5	60	170	15	20	M12	¹ / ₂
DKV090	3,1	33,338	1⁵/₁₆	205	100	117	60	25	90	114	104	136	12,5	60	170	15	20	M12	¹ / ₂
DKV080	2,9	34,925	1³/₈	205	85	112	60	25	80	98	91	122	10,5	60	170	15	20	M12	¹ / ₂
DKV080	2,9	34,925	1³/₈	205	85	112	60	25	80	98	91	122	10,5	60	170	15	20	M12	¹ / ₂
DKV080	2,9	34,925	1³/₈	205	85	112	60	25	80	98	91	122	10,5	60	170	15	20	M12	¹ / ₂
DKV080	2,9	34,925	1³/₈	205	85	112	60	25	80	98	91	122	10,5	60	170	15	20	M12	¹ / ₂
DKV090	3,1	34,925	1³/₈	205	100	117	60	25	90	114	104	136	12,5	60	170	15	20	M12	¹ / ₂
DKV090	3,1	34,925	1³/₈	205	100	117	60	25	90	114	104	136	12,5	60	170	15	20	M12	¹ / ₂
DKV090	3,1	34,925	1³/₈	205	100	117	60	25	90	114	104	136	12,5	60	170	15	20	M12	¹ / ₂
DKV090	3,1	34,925	1³/₈	205	100	117	60	25	90	114	104	136	12,5	60	170	15	20	M12	¹ / ₂
DKV080	2,9	35	–	205	85	112	60	25	80	98	91	122	10,5	60	170	15	20	M12	¹ / ₂
DKV080	2,9	35	–	205	85	112	60	25	80	98	91	122	10,5	60	170	15	20	M12	¹ / ₂
DKV080	2,9	35	–	205	85	112	60	25	80	98	91	122	10,5	60	170	15	20	M12	¹ / ₂
DKV080	2,9	35	–	205	85	112	60	25	80	98	91	122	10,5	60	170	15	20	M12	¹ / ₂
DKV090	3,1	35	–	205	100	117	60	25	90	114	104	136	12,5	60	170	15	20	M12	¹ / ₂
DKV090	3,1	35	–	205	100	117	60	25	90	114	104	136	12,5	60	170	15	20	M12	¹ / ₂
DKV090	3,1	35	–	205	100	117	60	25	90	114	104	136	12,5	60	170	15	20	M12	¹ / ₂
DKV090	3,1	35	–	205	100	117	60	25	90	114	104	136	12,5	60	170	15	20	M12	¹ / ₂



Plummer block housings

SNV, split
For bearings with tapered bore and adapter sleeve

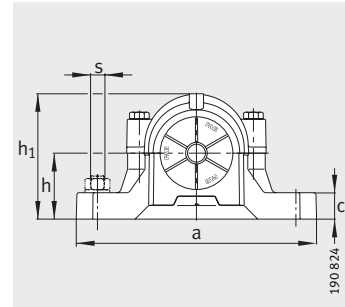
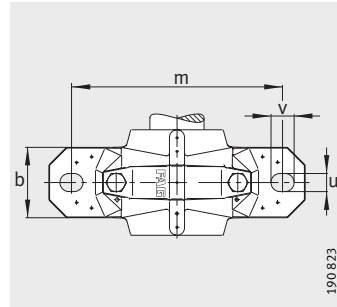

- ① Locating bearing
- ② Non-locating bearing

Dimension table (continued) · Dimensions in mm								
Designation								
Housing	Bearing	Adapter sleeve	Locating ring 2 pieces	Double lip seal	Labyrinth ring with round cord	Felt seal	V ring seal	Taconite seal
SNV085-L	1209-K-TVH-C3	H209X107	FRM85/6	DH509X107	TSV509X107	FSV509X107	DHV509X107	TCV509X107
SNV085-L	20209-K-TVP-C3	H209X107	FRM85/6	DH509X107	TSV509X107	FSV509X107	DHV509X107	TCV509X107
SNV085-L	2209-K-TVH-C3	H309X107	FRM85/4	DH509X107	TSV509X107	FSV509X107	DHV509X107	TCV509X107
SNV085-L	22209-E1-K	H309X107	FRM85/4	DH509X107	TSV509X107	FSV509X107	DHV509X107	TCV509X107
SNV100-L	1309-K-TVH-C3	H309X107	FRM100/9,5	DH609X107	TSV609X107	FSV609X107	DHV609X107	TCV609X107
SNV100-L	21309-E1-K	H309X107	FRM100/9,5	DH609X107	TSV609X107	FSV609X107	DHV609X107	TCV609X107
SNV100-L	2309-K-TVH-C3	H2309X107	FRM100/4	DH609X107	TSV609X107	FSV609X107	DHV609X107	TCV609X107
SNV100-L	22309-E1-K	H2309X107	FRM100/4	DH609X107	TSV609X107	FSV609X107	DHV609X107	TCV609X107
SNV085-L	1209-K-TVH-C3	H209X108	FRM85/6	DH509X107	TSV509X108	FSV509X108	DHV509X108	TCV509X108
SNV085-L	20209-K-TVP-C3	H209X108	FRM85/6	DH509X107	TSV509X108	FSV509X108	DHV509X108	TCV509X108
SNV085-L	2209-K-TVH-C3	H309X108	FRM85/4	DH509X107	TSV509X108	FSV509X108	DHV509X108	TCV509X108
SNV085-L	22209-E1-K	H309X108	FRM85/4	DH509X107	TSV509X108	FSV509X108	DHV509X108	TCV509X108
SNV100-L	1309-K-TVH-C3	H309X108	FRM100/9,5	DH609X107	TSV609X108	FSV609X108	DHV609X108	TCV609X108
SNV100-L	21309-E1-K	H309X108	FRM100/9,5	DH609X107	TSV609X108	FSV609X108	DHV609X108	TCV609X108
SNV100-L	2309-K-TVH-C3	H2309X108	FRM100/4	DH609X107	TSV609X108	FSV609X108	DHV609X108	TCV609X108
SNV100-L	22309-E1-K	H2309X108	FRM100/4	DH609X107	TSV609X108	FSV609X108	DHV609X108	TCV609X108
SNV100-L	1309-K-TVH-C3	H309X109	FRM100/9,5	DH609	TSV609	FSV609	DHV609	TCV609
SNV100-L	21309-E1-K	H309X109	FRM100/9,5	DH609	TSV609	FSV609	DHV609	TCV609
SNV100-L	2309-K-TVH-C3	H2309X109	FRM100/4	DH609	TSV609	FSV609	DHV609	TCV609
SNV100-L	22309-E1-K	H2309X109	FRM100/4	DH609	TSV609	FSV609	DHV609	TCV609
SNV085-L	1209-K-TVH-C3	H209	FRM85/6	DH509	TSV509	FSV509	DHV509	TCV509
SNV085-L	20209-K-TVP-C3	H209	FRM85/6	DH509	TSV509	FSV509	DHV509	TCV509
SNV085-L	2209-K-TVH-C3	H309	FRM85/4	DH509	TSV509	FSV509	DHV509	TCV509
SNV085-L	22209-E1-K	H309	FRM85/4	DH509	TSV509	FSV509	DHV509	TCV509
SNV100-L	1309-K-TVH-C3	H309	FRM100/9,5	DH609	TSV609	FSV609	DHV609	TCV609
SNV100-L	21309-E1-K	H309	FRM100/9,5	DH609	TSV609	FSV609	DHV609	TCV609
SNV100-L	2309-K-TVH-C3	H2309	FRM100/4	DH609	TSV609	FSV609	DHV609	TCV609
SNV100-L	22309-E1-K	H2309	FRM100/4	DH609	TSV609	FSV609	DHV609	TCV609
SNV090-L	1210-K-TVH-C3	H210X110	FRM90/10,5	DH510X110	TSV510X110	FSV510X110	DHV510X110	TCV510X110
SNV090-L	20210-K-TVP-C3	H210X110	FRM90/10,5	DH510X110	TSV510X110	FSV510X110	DHV510X110	TCV510X110
SNV090-L	2210-K-TVH-C3	H310X110	FRM90/9	DH510X110	TSV510X110	FSV510X110	DHV510X110	TCV510X110
SNV090-L	22210-E1-K	H310X110	FRM90/9	DH510X110	TSV510X110	FSV510X110	DHV510X110	TCV510X110
SNV110-L	1310-K-TVH-C3	H310X110	FRM110/10,5	DH610X110	TSV610X110	FSV610X110	DHV610X110	TCV610X110
SNV110-L	21310-E1-K	H310X110	FRM110/10,5	DH610X110	TSV610X110	FSV610X110	DHV610X110	TCV610X110
SNV110-L	2310-K-TVH-C3	H2310X110	FRM110/4	DH610X110	TSV610X110	FSV610X110	DHV610X110	TCV610X110
SNV110-L	22310-E1-K	H2310X110	FRM110/4	DH610X110	TSV610X110	FSV610X110	DHV610X110	TCV610X110

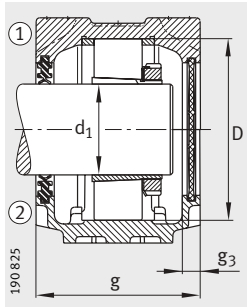

Double lip seal DH
Cover DKV

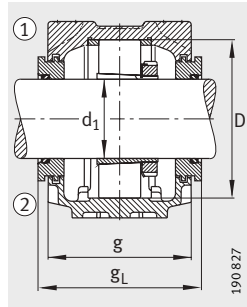

Labyrinth ring TSV

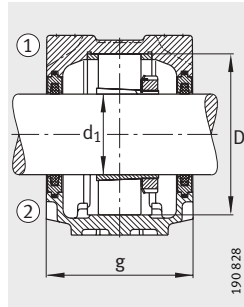

Felt seal FSV

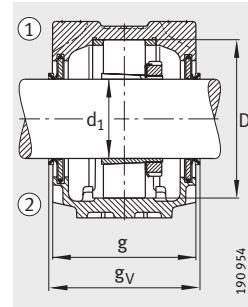

V ring seal DHV

Cover	Mass m ≈kg	Dimensions																	
		Housing d ₁	a	g	h ₁	b	c	D	g _L	g _V	g _T	g ₃	h	m	u	v	s		
																	mm	inch	mm
DKV085	2,8	36,513	1 ⁷ / ₁₆	205	87	114	60	25	85	101	91	123	12,5	60	170	15	20	M12	1/2
DKV085	2,8	36,513	1 ⁷ / ₁₆	205	87	114	60	25	85	101	91	123	12,5	60	170	15	20	M12	1/2
DKV085	2,8	36,513	1 ⁷ / ₁₆	205	87	114	60	25	85	101	91	123	12,5	60	170	15	20	M12	1/2
DKV085	2,8	36,513	1 ⁷ / ₁₆	205	87	114	60	25	85	101	91	123	12,5	60	170	15	20	M12	1/2
DKV100	4,3	36,513	1 ⁷ / ₁₆	255	105	133	70	28	100	119	109	141	12,5	70	210	18	23	M16	5/8
DKV100	4,3	36,513	1 ⁷ / ₁₆	255	105	133	70	28	100	119	109	141	12,5	70	210	18	23	M16	5/8
DKV100	4,3	36,513	1 ⁷ / ₁₆	255	105	133	70	28	100	119	109	141	12,5	70	210	18	23	M16	5/8
DKV100	4,3	36,513	1 ⁷ / ₁₆	255	105	133	70	28	100	119	109	141	12,5	70	210	18	23	M16	5/8
DKV085	2,8	38,1	1 ¹ / ₂	205	87	114	60	25	85	101	93	125	12,5	60	170	15	20	M12	1/2
DKV085	2,8	38,1	1 ¹ / ₂	205	87	114	60	25	85	101	93	125	12,5	60	170	15	20	M12	1/2
DKV085	2,8	38,1	1 ¹ / ₂	205	87	114	60	25	85	101	93	125	12,5	60	170	15	20	M12	1/2
DKV085	2,8	38,1	1 ¹ / ₂	205	87	114	60	25	85	101	93	125	12,5	60	170	15	20	M12	1/2
DKV100	4,3	38,1	1 ¹ / ₂	255	105	133	70	28	100	119	111	143	12,5	70	210	18	23	M16	5/8
DKV100	4,3	38,1	1 ¹ / ₂	255	105	133	70	28	100	119	111	143	12,5	70	210	18	23	M16	5/8
DKV100	4,3	38,1	1 ¹ / ₂	255	105	133	70	28	100	119	111	143	12,5	70	210	18	23	M16	5/8
DKV100	4,3	38,1	1 ¹ / ₂	255	105	133	70	28	100	119	111	143	12,5	70	210	18	23	M16	5/8
DKV100	4,3	39,688	1 ⁹ / ₁₆	255	105	133	70	28	100	119	109	141	12,5	70	210	18	23	M16	5/8
DKV100	4,3	39,688	1 ⁹ / ₁₆	255	105	133	70	28	100	119	109	141	12,5	70	210	18	23	M16	5/8
DKV100	4,3	39,688	1 ⁹ / ₁₆	255	105	133	70	28	100	119	109	141	12,5	70	210	18	23	M16	5/8
DKV100	4,3	39,688	1 ⁹ / ₁₆	255	105	133	70	28	100	119	109	141	12,5	70	210	18	23	M16	5/8
DKV085	2,8	40	–	205	87	114	60	25	85	101	93	125	12,5	60	170	15	20	M12	1/2
DKV085	2,8	40	–	205	87	114	60	25	85	101	93	125	12,5	60	170	15	20	M12	1/2
DKV085	2,8	40	–	205	87	114	60	25	85	101	93	125	12,5	60	170	15	20	M12	1/2
DKV085	2,8	40	–	205	87	114	60	25	85	101	93	125	12,5	60	170	15	20	M12	1/2
DKV100	4,3	40	–	255	105	133	70	28	100	119	111	143	12,5	70	210	18	23	M16	5/8
DKV100	4,3	40	–	255	105	133	70	28	100	119	111	143	12,5	70	210	18	23	M16	5/8
DKV100	4,3	40	–	255	105	133	70	28	100	119	111	143	12,5	70	210	18	23	M16	5/8
DKV100	4,3	40	–	255	105	133	70	28	100	119	111	143	12,5	70	210	18	23	M16	5/8
DKV090	3,1	41,275	1 ⁵ / ₈	205	100	117	60	25	90	114	106	138	12,5	60	170	15	20	M12	1/2
DKV090	3,1	41,275	1 ⁵ / ₈	205	100	117	60	25	90	114	106	138	12,5	60	170	15	20	M12	1/2
DKV090	3,1	41,275	1 ⁵ / ₈	205	100	117	60	25	90	114	106	138	12,5	60	170	15	20	M12	1/2
DKV090	3,1	41,275	1 ⁵ / ₈	205	100	117	60	25	90	114	106	138	12,5	60	170	15	20	M12	1/2
DKV110	4,9	41,275	1 ⁵ / ₈	255	110	139	70	30	110	124	116	148	12,5	70	210	18	23	M16	5/8
DKV110	4,9	41,275	1 ⁵ / ₈	255	110	139	70	30	110	124	116	148	12,5	70	210	18	23	M16	5/8
DKV110	4,9	41,275	1 ⁵ / ₈	255	110	139	70	30	110	124	116	148	12,5	70	210	18	23	M16	5/8
DKV110	4,9	41,275	1 ⁵ / ₈	255	110	139	70	30	110	124	116	148	12,5	70	210	18	23	M16	5/8



Plummer block housings

SNV, split
For bearings with tapered bore and adapter sleeve

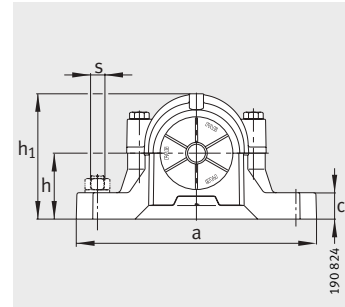
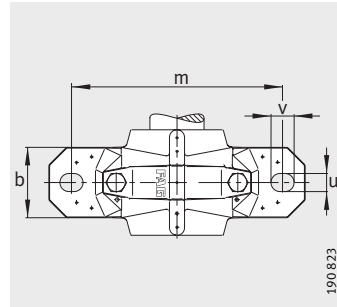

- ① Locating bearing
- ② Non-locating bearing

Dimension table (continued) · Dimensions in mm								
Designation								
Housing	Bearing	Adapter sleeve	Locating ring 2 pieces	Double lip seal	Labyrinth ring with round cord	Felt seal	V ring seal	Taconite seal
SNV090-L	1210-K-TVH-C3	H210X111	FRM90/10,5	DH510X110	TSV510X111	FSV510X111	DHV510X111	TCV510X111
SNV090-L	20210-K-TVP-C3	H210X111	FRM90/10,5	DH510X110	TSV510X111	FSV510X111	DHV510X111	TCV510X111
SNV090-L	2210-K-TVH-C3	H310X111	FRM90/9	DH510X110	TSV510X111	FSV510X111	DHV510X111	TCV510X111
SNV090-L	22210-E1-K	H310X111	FRM90/9	DH510X110	TSV510X111	FSV510X111	DHV510X111	TCV510X111
SNV110-L	1310-K-TVH-C3	H310X111	FRM110/10,5	DH610X110	TSV610X111	FSV610X111	DHV610X111	TCV610X111
SNV110-L	21310-E1-K	H310X111	FRM110/10,5	DH610X110	TSV610X111	FSV610X111	DHV610X111	TCV610X111
SNV110-L	2310-K-TVH-C3	H2310X111	FRM110/4	DH610X110	TSV610X111	FSV610X111	DHV610X111	TCV610X111
SNV110-L	22310-E1-K	H2310X111	FRM110/4	DH610X110	TSV610X111	FSV610X111	DHV610X111	TCV610X111
SNV090-L	1210-K-TVH-C3	H210X112	FRM90/10,5	DH510	TSV510X112	FSV510	DHV510	TCV510
SNV090-L	20210-K-TVP-C3	H210X112	FRM90/10,5	DH510	TSV510X112	FSV510	DHV510	TCV510
SNV090-L	2210-K-TVH-C3	H310X112	FRM90/9	DH510	TSV510X112	FSV510	DHV510	TCV510
SNV090-L	22210-E1-K	H310X112	FRM90/9	DH510	TSV510X112	FSV510	DHV510	TCV510
SNV110-L	1310-K-TVH-C3	H310X112	FRM110/10,5	DH610	TSV610X112	FSV610	DHV610	TCV610
SNV110-L	21310-E1-K	H310X112	FRM110/10,5	DH610	TSV610X112	FSV610	DHV610	TCV610
SNV110-L	2310-K-TVH-C3	H2310X112	FRM110/4	DH610	TSV610X112	FSV610	DHV610	TCV610
SNV110-L	22310-E1-K	H2310X112	FRM110/4	DH610	TSV610X112	FSV610	DHV610	TCV610
SNV090-L	1210-K-TVH-C3	H210	FRM90/10,5	DH510	TSV510	FSV510	DHV510	TCV510
SNV090-L	20210-K-TVP-C3	H210	FRM90/10,5	DH510	TSV510	FSV510	DHV510	TCV510
SNV090-L	2210-K-TVH-C3	H310	FRM90/9	DH510	TSV510	FSV510	DHV510	TCV510
SNV090-L	22210-E1-K	H310	FRM90/9	DH510	TSV510	FSV510	DHV510	TCV510
SNV110-L	1310-K-TVH-C3	H310	FRM110/10,5	DH610	TSV610	FSV610	DHV610	TCV610
SNV110-L	21310-E1-K	H310	FRM110/10,5	DH610	TSV610	FSV610	DHV610	TCV610
SNV110-L	2310-K-TVH-C3	H2310	FRM110/4	DH610	TSV610	FSV610	DHV610	TCV610
SNV110-L	22310-E1-K	H2310	FRM110/4	DH610	TSV610	FSV610	DHV610	TCV610
SNV100-L	1211-K-TVH-C3	H211X114	FRM100/11,5	DH511X114	TSV511X114	FSV511X114	DHV511X114	TCV511X114
SNV100-L	20211-K-TVP-C3	H211X114	FRM100/11,5	DH511X114	TSV511X114	FSV511X114	DHV511X114	TCV511X114
SNV100-L	2211-K-TVH-C3	H311X114	FRM100/9,5	DH511X114	TSV511X114	FSV511X114	DHV511X114	TCV511X114
SNV100-L	22211-E1-K	H311X114	FRM100/9,5	DH511X114	TSV511X114	FSV511X114	DHV511X114	TCV511X114
SNV120-L	1311-K-TVH-C3	H311X114	FRM120/11	DH611X114	TSV611X114	FSV611X114	DHV611X114	TCV611X114
SNV120-L	20311-K-TVP-C3	H311X114	FRM120/11	DH611X114	TSV611X114	FSV611X114	DHV611X114	TCV611X114
SNV120-L	21311-E1-K	H311X114	FRM120/11	DH611X114	TSV611X114	FSV611X114	DHV611X114	TCV611X114
SNV120-L	2311-K-TVH-C3	H2311X114	FRM120/4	DH611X114	TSV611X114	FSV611X114	DHV611X114	TCV611X114
SNV120-L	22311-E1-K	H2311X114	FRM120/4	DH611X114	TSV611X114	FSV611X114	DHV611X114	TCV611X114

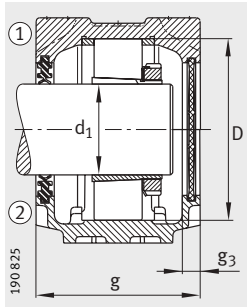

Double lip seal DH
Cover DKV

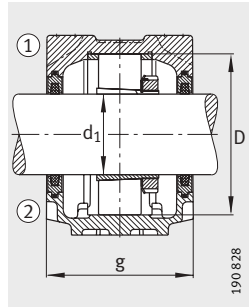

Felt seal FSV

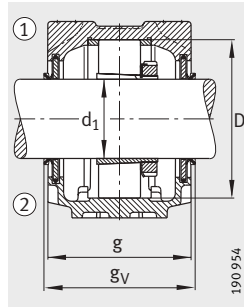

V ring seal DHV

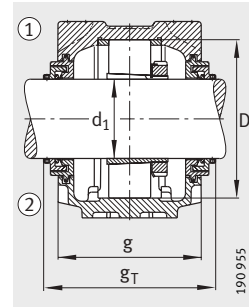

Taconite seal TCV

Cover	Housing ≈kg	Dimensions																	
		d ₁		a	g	h ₁	b	c	D	g _L	g _V	g _T	g ₃	h	m	u	v	s	
		mm	inch																mm
DKV090	3,1	42,863	1 ¹¹ / ₁₆	205	100	117	60	25	90	114	106	138	12,5	60	170	15	20	M12	1/2
DKV090	3,1	42,863	1 ¹¹ / ₁₆	205	100	117	60	25	90	114	106	138	12,5	60	170	15	20	M12	1/2
DKV090	3,1	42,863	1 ¹¹ / ₁₆	205	100	117	60	25	90	114	106	138	12,5	60	170	15	20	M12	1/2
DKV090	3,1	42,863	1 ¹¹ / ₁₆	205	100	117	60	25	90	114	106	138	12,5	60	170	15	20	M12	1/2
DKV110	4,9	42,863	1 ¹¹ / ₁₆	255	110	139	70	30	110	124	116	148	12,5	70	210	18	23	M16	5/8
DKV110	4,9	42,863	1 ¹¹ / ₁₆	255	110	139	70	30	110	124	116	148	12,5	70	210	18	23	M16	5/8
DKV110	4,9	42,863	1 ¹¹ / ₁₆	255	110	139	70	30	110	124	116	148	12,5	70	210	18	23	M16	5/8
DKV110	4,9	42,863	1 ¹¹ / ₁₆	255	110	139	70	30	110	124	116	148	12,5	70	210	18	23	M16	5/8
DKV090	3,1	44,45	1 ³ / ₄	205	100	117	60	25	90	114	106	138	12,5	60	170	15	20	M12	1/2
DKV090	3,1	44,45	1 ³ / ₄	205	100	117	60	25	90	114	106	138	12,5	60	170	15	20	M12	1/2
DKV090	3,1	44,45	1 ³ / ₄	205	100	117	60	25	90	114	106	138	12,5	60	170	15	20	M12	1/2
DKV090	3,1	44,45	1 ³ / ₄	205	100	117	60	25	90	114	106	138	12,5	60	170	15	20	M12	1/2
DKV110	4,9	44,45	1 ³ / ₄	255	110	139	70	30	110	124	116	148	12,5	70	210	18	23	M16	5/8
DKV110	4,9	44,45	1 ³ / ₄	255	110	139	70	30	110	124	116	148	12,5	70	210	18	23	M16	5/8
DKV110	4,9	44,45	1 ³ / ₄	255	110	139	70	30	110	124	116	148	12,5	70	210	18	23	M16	5/8
DKV110	4,9	44,45	1 ³ / ₄	255	110	139	70	30	110	124	116	148	12,5	70	210	18	23	M16	5/8
DKV090	3,1	45	-	205	100	117	60	25	90	114	106	138	12,5	60	170	15	20	M12	1/2
DKV090	3,1	45	-	205	100	117	60	25	90	114	106	138	12,5	60	170	15	20	M12	1/2
DKV090	3,1	45	-	205	100	117	60	25	90	114	106	138	12,5	60	170	15	20	M12	1/2
DKV090	3,1	45	-	205	100	117	60	25	90	114	106	138	12,5	60	170	15	20	M12	1/2
DKV110	4,9	45	-	255	110	139	70	30	110	124	116	148	12,5	70	210	18	23	M16	5/8
DKV110	4,9	45	-	255	110	139	70	30	110	124	116	148	12,5	70	210	18	23	M16	5/8
DKV110	4,9	45	-	255	110	139	70	30	110	124	116	148	12,5	70	210	18	23	M16	5/8
DKV110	4,9	45	-	255	110	139	70	30	110	124	116	148	12,5	70	210	18	23	M16	5/8
DKV100	4,3	47,625	1 ⁷ / ₈	255	105	133	70	28	100	119	111	143	12,5	70	210	18	23	M16	5/8
DKV100	4,3	47,625	1 ⁷ / ₈	255	105	133	70	28	100	119	111	143	12,5	70	210	18	23	M16	5/8
DKV100	4,3	47,625	1 ⁷ / ₈	255	105	133	70	28	100	119	111	143	12,5	70	210	18	23	M16	5/8
DKV100	4,3	47,625	1 ⁷ / ₈	255	105	133	70	28	100	119	111	143	12,5	70	210	18	23	M16	5/8
DKV120	6,1	47,625	1 ⁷ / ₈	275	115	155	80	30	120	129	121	153	12,5	80	230	18	23	M16	5/8
DKV120	6,1	47,625	1 ⁷ / ₈	275	115	155	80	30	120	129	121	153	12,5	80	230	18	23	M16	5/8
DKV120	6,1	47,625	1 ⁷ / ₈	275	115	155	80	30	120	129	121	153	12,5	80	230	18	23	M16	5/8
DKV120	6,1	47,625	1 ⁷ / ₈	275	115	155	80	30	120	129	121	153	12,5	80	230	18	23	M16	5/8
DKV120	6,1	47,625	1 ⁷ / ₈	275	115	155	80	30	120	129	121	153	12,5	80	230	18	23	M16	5/8
DKV120	6,1	47,625	1 ⁷ / ₈	275	115	155	80	30	120	129	121	153	12,5	80	230	18	23	M16	5/8



Plummer block housings

SNV, split
For bearings with tapered bore and adapter sleeve

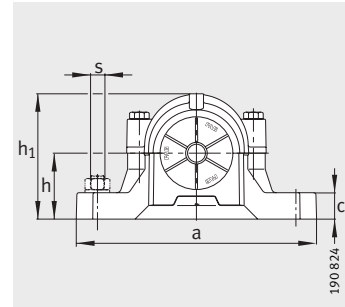
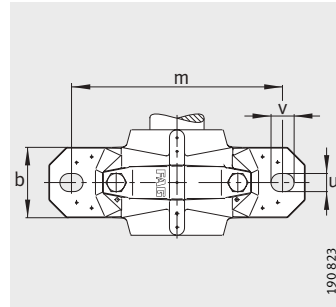

- ① Locating bearing
- ② Non-locating bearing

Dimension table (continued) - Dimensions in mm

Designation								
Housing	Bearing	Adapter sleeve	Locating ring 2 pieces	Double lip seal	Labyrinth ring with round cord	Felt seal	V ring seal	Taconite seal
SNV100-L	1211-K-TVH-C3	H211X115	FRM100/11,5	DH511	TSV511X115	FSV511X115	DHV511X115	TCV511X115
SNV100-L	20211-K-TVP-C3	H211X115	FRM100/11,5	DH511	TSV511X115	FSV511X115	DHV511X115	TCV511X115
SNV100-L	2211-K-TVH-C3	H311X115	FRM100/9,5	DH511	TSV511X115	FSV511X115	DHV511X115	TCV511X115
SNV100-L	22211-E1-K	H311X115	FRM100/9,5	DH511	TSV511X115	FSV511X115	DHV511X115	TCV511X115
SNV120-L	1311-K-TVH-C3	H311X115	FRM120/11	DH611	TSV611X115	FSV611X115	DHV611X115	TCV611X115
SNV120-L	20311-K-TVP-C3	H311X115	FRM120/11	DH611	TSV611X115	FSV611X115	DHV611X115	TCV611X115
SNV120-L	21311-E1-K	H311X115	FRM120/11	DH611	TSV611X115	FSV611X115	DHV611X115	TCV611X115
SNV120-L	2311-K-TVH-C3	H2311X115	FRM120/4	DH611	TSV611X115	FSV611X115	DHV611X115	TCV611X115
SNV120-L	22311-E1-K	H2311X115	FRM120/4	DH611	TSV611X115	FSV611X115	DHV611X115	TCV611X115
SNV100-L	1211-K-TVH-C3	H211	FRM100/11,5	DH511	TSV511	FSV511	DHV511	TCV511
SNV100-L	20211-K-TVP-C3	H211	FRM100/11,5	DH511	TSV511	FSV511	DHV511	TCV511
SNV100-L	2211-K-TVH-C3	H311	FRM100/9,5	DH511	TSV511	FSV511	DHV511	TCV511
SNV100-L	22211-E1-K	H311	FRM100/9,5	DH511	TSV511	FSV511	DHV511	TCV511
SNV120-L	1311-K-TVH-C3	H311	FRM120/11	DH611	TSV611	FSV611	DHV611	TCV611
SNV120-L	20311-K-TVP-C3	H311	FRM120/11	DH611	TSV611	FSV611	DHV611	TCV611
SNV120-L	21311-E1-K	H311	FRM120/11	DH611	TSV611	FSV611	DHV611	TCV611
SNV120-L	2311-K-TVH-C3	H2311	FRM120/4	DH611	TSV611	FSV611	DHV611	TCV611
SNV120-L	22311-E1-K	H2311	FRM120/4	DH611	TSV611	FSV611	DHV611	TCV611
SNV100-L	1211-K-TVH-C3	H211X200	FRM100/11,5	DH511	TSV511X200	FSV511	DHV511	TCV511X200
SNV100-L	20211-K-TVP-C3	H211X200	FRM100/11,5	DH511	TSV511X200	FSV511	DHV511	TCV511X200
SNV100-L	2211-K-TVH-C3	H311X200	FRM100/9,5	DH511	TSV511X200	FSV511	DHV511	TCV511X200
SNV100-L	22211-E1-K	H311X200	FRM100/9,5	DH511	TSV511X200	FSV511	DHV511	TCV511X200
SNV120-L	1311-K-TVH-C3	H311X200	FRM120/11	DH611	TSV611X200	FSV611	DHV611	TCV611X200
SNV120-L	20311-K-TVP-C3	H311X200	FRM120/11	DH611	TSV611X200	FSV611	DHV611	TCV611X200
SNV120-L	21311-E1-K	H311X200	FRM120/11	DH611	TSV611X200	FSV611	DHV611	TCV611X200
SNV120-L	2311-K-TVH-C3	H2311X200	FRM120/4	DH611	TSV611X200	FSV611	DHV611	TCV611X200
SNV120-L	22311-E1-K	H2311X200	FRM120/4	DH611	TSV611X200	FSV611	DHV611	TCV611X200

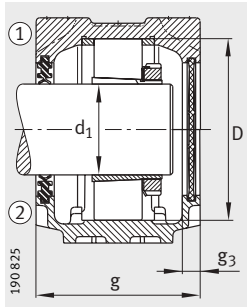

Double lip seal DH
Cover DKV

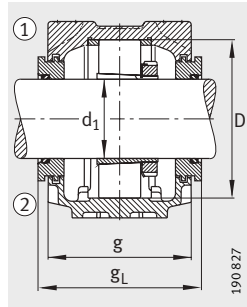

Labyrinth ring TSV

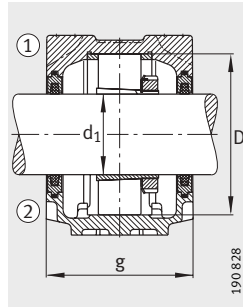

Felt seal FSV

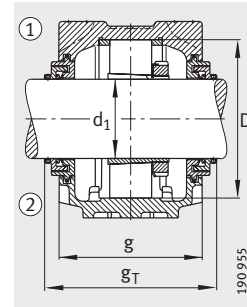

Taconite seal TCV

Cover	Mass m Housing ≈kg	Dimensions																	
		d ₁		a	g	h ₁	b	c	D	g _L	g _V	g _T	g ₃	h	m	u	v	s	
		mm	inch															mm	inch
DKV100	4,3	49,213	1¹⁵/₁₆	255	105	133	70	28	100	119	111	143	12,5	70	210	18	23	M16	⁵ / ₈
DKV100	4,3	49,213	1¹⁵/₁₆	255	105	133	70	28	100	119	111	143	12,5	70	210	18	23	M16	⁵ / ₈
DKV100	4,3	49,213	1¹⁵/₁₆	255	105	133	70	28	100	119	111	143	12,5	70	210	18	23	M16	⁵ / ₈
DKV100	4,3	49,213	1¹⁵/₁₆	255	105	133	70	28	100	119	111	143	12,5	70	210	18	23	M16	⁵ / ₈
DKV120	6,1	49,213	1¹⁵/₁₆	275	115	155	80	30	120	129	121	153	12,5	80	230	18	23	M16	⁵ / ₈
DKV120	6,1	49,213	1¹⁵/₁₆	275	115	155	80	30	120	129	121	153	12,5	80	230	18	23	M16	⁵ / ₈
DKV120	6,1	49,213	1¹⁵/₁₆	275	115	155	80	30	120	129	121	153	12,5	80	230	18	23	M16	⁵ / ₈
DKV120	6,1	49,213	1¹⁵/₁₆	275	115	155	80	30	120	129	121	153	12,5	80	230	18	23	M16	⁵ / ₈
DKV120	6,1	49,213	1¹⁵/₁₆	275	115	155	80	30	120	129	121	153	12,5	80	230	18	23	M16	⁵ / ₈
DKV100	4,3	50	–	255	105	133	70	28	100	119	111	143	12,5	70	210	18	23	M16	⁵ / ₈
DKV100	4,3	50	–	255	105	133	70	28	100	119	111	143	12,5	70	210	18	23	M16	⁵ / ₈
DKV100	4,3	50	–	255	105	133	70	28	100	119	111	143	12,5	70	210	18	23	M16	⁵ / ₈
DKV100	4,3	50	–	255	105	133	70	28	100	119	111	143	12,5	70	210	18	23	M16	⁵ / ₈
DKV120	6,1	50	–	275	115	155	80	30	120	129	121	153	12,5	80	230	18	23	M16	⁵ / ₈
DKV120	6,1	50	–	275	115	155	80	30	120	129	121	153	12,5	80	230	18	23	M16	⁵ / ₈
DKV120	6,1	50	–	275	115	155	80	30	120	129	121	153	12,5	80	230	18	23	M16	⁵ / ₈
DKV120	6,1	50	–	275	115	155	80	30	120	129	121	153	12,5	80	230	18	23	M16	⁵ / ₈
DKV100	4,3	50,8	2	255	105	133	70	28	100	119	111	143	12,5	70	210	18	23	M16	⁵ / ₈
DKV100	4,3	50,8	2	255	105	133	70	28	100	119	111	143	12,5	70	210	18	23	M16	⁵ / ₈
DKV100	4,3	50,8	2	255	105	133	70	28	100	119	111	143	12,5	70	210	18	23	M16	⁵ / ₈
DKV100	4,3	50,8	2	255	105	133	70	28	100	119	111	143	12,5	70	210	18	23	M16	⁵ / ₈
DKV120	6,1	50,8	2	275	115	155	80	30	120	129	121	153	12,5	80	230	18	23	M16	⁵ / ₈
DKV120	6,1	50,8	2	275	115	155	80	30	120	129	121	153	12,5	80	230	18	23	M16	⁵ / ₈
DKV120	6,1	50,8	2	275	115	155	80	30	120	129	121	153	12,5	80	230	18	23	M16	⁵ / ₈
DKV120	6,1	50,8	2	275	115	155	80	30	120	129	121	153	12,5	80	230	18	23	M16	⁵ / ₈
DKV120	6,1	50,8	2	275	115	155	80	30	120	129	121	153	12,5	80	230	18	23	M16	⁵ / ₈



Plummer block housings

SNV, split
For bearings with tapered bore and adapter sleeve

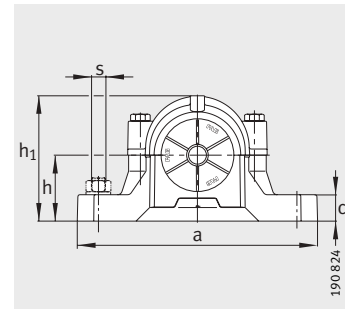
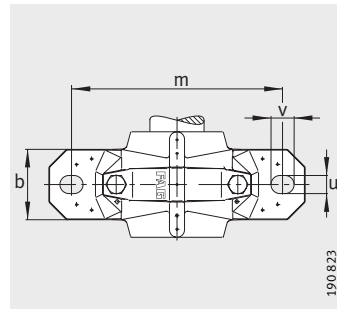

- ① Locating bearing
- ② Non-locating bearing

Dimension table (continued) · Dimensions in mm								
Designation								
Housing	Bearing	Adapter sleeve	Locating ring 2 pieces	Double lip seal	Labyrinth ring with round cord	Felt seal	V ring seal	Taconite seal
SNV110-L	1212-K-TVH-C3	H212X202	FRM110/13	DH512	TSV512X202	FSV512X202	DHV512	TCV512X202
SNV110-L	20212-K-TVP-C3	H212X202	FRM110/13	DH512	TSV512X202	FSV512X202	DHV512	TCV512X202
SNV110-L	2212-K-TVH-C3	H312X202	FRM110/10	DH512	TSV512X202	FSV512X202	DHV512	TCV512X202
SNV110-L	22212-E1-K	H312X202	FRM110/10	DH512	TSV512X202	FSV512X202	DHV512	TCV512X202
SNV130-L	1312-K-TVH-C3	H312X202	FRM130/12,5	DH612	TSV612X202	FSV612X202	DHV612	TCV612X202
SNV130-L	20312-K-TVP-C3	H312X202	FRM130/12,5	DH612	TSV612X202	FSV612X202	DHV612	TCV612X202
SNV130-L	21312-E1-K	H312X202	FRM130/12,5	DH612	TSV612X202	FSV612X202	DHV612	TCV612X202
SNV130-L	2312-K-TVH-C3	H2312X202	FRM130/5	DH612	TSV612X202	FSV612X202	DHV612	TCV612X202
SNV130-L	22312-E1-K	H2312X202	FRM130/5	DH612	TSV612X202	FSV612X202	DHV612	TCV612X202
SNV110-L	1212-K-TVH-C3	H212	FRM110/13	DH512	TSV512	FSV512	DHV512	TCV512
SNV110-L	20212-K-TVP-C3	H212	FRM110/13	DH512	TSV512	FSV512	DHV512	TCV512
SNV110-L	2212-K-TVH-C3	H312	FRM110/10	DH512	TSV512	FSV512	DHV512	TCV512
SNV110-L	22212-E1-K	H312	FRM110/10	DH512	TSV512	FSV512	DHV512	TCV512
SNV130-L	1312-K-TVH-C3	H312	FRM130/12,5	DH612	TSV612	FSV612	DHV612	TCV612
SNV130-L	20312-K-TVP-C3	H312	FRM130/12,5	DH612	TSV612	FSV612	DHV612	TCV612
SNV130-L	21312-E1-K	H312	FRM130/12,5	DH612	TSV612	FSV612	DHV612	TCV612
SNV130-L	2312-K-TVH-C3	H2312	FRM130/5	DH612	TSV612	FSV612	DHV612	TCV612
SNV130-L	22312-E1-K	H2312	FRM130/5	DH612	TSV612	FSV612	DHV612	TCV612
SNV120-L	1213-K-TVH-C3	H213X203	FRM120/14	DH513X203	TSV513X203	FSV513X203	DHV513X203	TCV513X203
SNV120-L	20213-K-TVP-C3	H213X203	FRM120/14	DH513X203	TSV513X203	FSV513X203	DHV513X203	TCV513X203
SNV120-L	2213-K-TVH-C3	H313X203	FRM120/10	DH513X203	TSV513X203	FSV513X203	DHV513X203	TCV513X203
SNV120-L	22213-E1-K	H313X203	FRM120/10	DH513X203	TSV513X203	FSV513X203	DHV513X203	TCV513X203
SNV140-L	1313-K-TVH-C3	H313X203	FRM140/12,5	DH613X203	TSV613X203	FSV613X203	DHV613X203	TCV613X203
SNV140-L	20313-K-MB-C3	H313X203	FRM140/12,5	DH613X203	TSV613X203	FSV613X203	DHV613X203	TCV613X203
SNV140-L	21313-E1-K	H313X203	FRM140/12,5	DH613X203	TSV613X203	FSV613X203	DHV613X203	TCV613X203
SNV140-L	2313-K-TVH-C3	H2313X203	FRM140/5	DH613X203	TSV613X203	FSV613X203	DHV613X203	TCV613X203
SNV140-L	22313-E1-K	H2313X203	FRM140/5	DH613X203	TSV613X203	FSV613X203	DHV613X203	TCV613X203
SNV120-L	1213-K-TVH-C3	H213X204	FRM120/14	DH513X203	TSV513X204	FSV513X204	DHV513X204	TCV513X204
SNV120-L	20213-K-TVP-C3	H213X204	FRM120/14	DH513X203	TSV513X204	FSV513X204	DHV513X204	TCV513X204
SNV120-L	2213-K-TVH-C3	H313X204	FRM120/10	DH513X203	TSV513X204	FSV513X204	DHV513X204	TCV513X204
SNV120-L	22213-E1-K	H313X204	FRM120/10	DH513X203	TSV513X204	FSV513X204	DHV513X204	TCV513X204
SNV140-L	1313-K-TVH-C3	H313X204	FRM140/12,5	DH613X203	TSV613X204	FSV613X204	DHV613X204	TCV613X204
SNV140-L	20313-K-MB-C3	H313X204	FRM140/12,5	DH613X203	TSV613X204	FSV613X204	DHV613X204	TCV613X204
SNV140-L	21313-E1-K	H313X204	FRM140/12,5	DH613X203	TSV613X204	FSV613X204	DHV613X204	TCV613X204
SNV140-L	2313-K-TVH-C3	H2313X204	FRM140/5	DH613X203	TSV613X204	FSV613X204	DHV613X204	TCV613X204
SNV140-L	22313-E1-K	H2313X204	FRM140/5	DH613X203	TSV613X204	FSV613X204	DHV613X204	TCV613X204

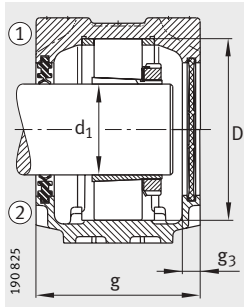

Double lip seal DH
Cover DKV

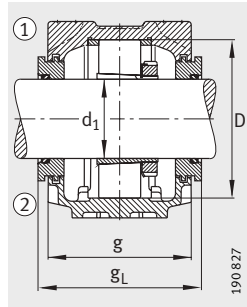

Labyrinth ring TSV

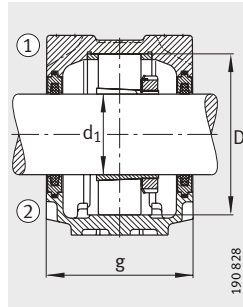

Felt seal FSV

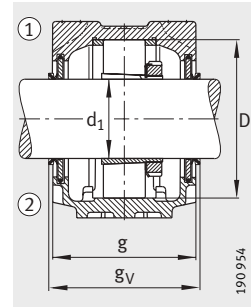

V ring seal DHV

Cover	Mass m Housing ≈kg	Dimensions																	
		d ₁		a	g	h ₁	b	c	D	g _L	g _V	g _T	g ₃	h	m	u	v	s	
		mm	inch															mm	inch
DKV110	4,9	53,975	2 ¹ / ₈	255	110	139	70	30	110	124	116	148	12,5	70	210	18	23	M16	5/8
DKV110	4,9	53,975	2 ¹ / ₈	255	110	139	70	30	110	124	116	148	12,5	70	210	18	23	M16	5/8
DKV110	4,9	53,975	2 ¹ / ₈	255	110	139	70	30	110	124	116	148	12,5	70	210	18	23	M16	5/8
DKV110	4,9	53,975	2 ¹ / ₈	255	110	139	70	30	110	124	116	148	12,5	70	210	18	23	M16	5/8
DKV130	6,8	53,975	2 ¹ / ₈	280	120	161	80	30	130	134	126	158	12,5	80	230	18	23	M16	5/8
DKV130	6,8	53,975	2 ¹ / ₈	280	120	161	80	30	130	134	126	158	12,5	80	230	18	23	M16	5/8
DKV130	6,8	53,975	2 ¹ / ₈	280	120	161	80	30	130	134	126	158	12,5	80	230	18	23	M16	5/8
DKV130	6,8	53,975	2 ¹ / ₈	280	120	161	80	30	130	134	126	158	12,5	80	230	18	23	M16	5/8
DKV130	6,8	53,975	2 ¹ / ₈	280	120	161	80	30	130	134	126	158	12,5	80	230	18	23	M16	5/8
DKV110	4,9	55	–	255	110	139	70	30	110	124	116	148	12,5	70	210	18	23	M16	5/8
DKV110	4,9	55	–	255	110	139	70	30	110	124	116	148	12,5	70	210	18	23	M16	5/8
DKV110	4,9	55	–	255	110	139	70	30	110	124	116	148	12,5	70	210	18	23	M16	5/8
DKV110	4,9	55	–	255	110	139	70	30	110	124	116	148	12,5	70	210	18	23	M16	5/8
DKV130	6,8	55	–	280	120	161	80	30	130	134	126	158	12,5	80	230	18	23	M16	5/8
DKV130	6,8	55	–	280	120	161	80	30	130	134	126	158	12,5	80	230	18	23	M16	5/8
DKV130	6,8	55	–	280	120	161	80	30	130	134	126	158	12,5	80	230	18	23	M16	5/8
DKV130	6,8	55	–	280	120	161	80	30	130	134	126	158	12,5	80	230	18	23	M16	5/8
DKV120	6,1	55,563	2 ³ / ₁₆	275	115	155	80	30	120	129	121	153	12,5	80	230	18	23	M16	5/8
DKV120	6,1	55,563	2 ³ / ₁₆	275	115	155	80	30	120	129	121	153	12,5	80	230	18	23	M16	5/8
DKV120	6,1	55,563	2 ³ / ₁₆	275	115	155	80	30	120	129	121	153	12,5	80	230	18	23	M16	5/8
DKV120	6,1	55,563	2 ³ / ₁₆	275	115	155	80	30	120	129	121	153	12,5	80	230	18	23	M16	5/8
DKV140	9,3	55,563	2 ³ / ₁₆	315	135	183	90	32	140	150,3	139	172	15	95	260	22	27	M20	3/4
DKV140	9,3	55,563	2 ³ / ₁₆	315	135	183	90	32	140	150,3	139	172	15	95	260	22	27	M20	3/4
DKV140	9,3	55,563	2 ³ / ₁₆	315	135	183	90	32	140	150,3	139	172	15	95	260	22	27	M20	3/4
DKV140	9,3	55,563	2 ³ / ₁₆	315	135	183	90	32	140	150,3	139	172	15	95	260	22	27	M20	3/4
DKV140	9,3	55,563	2 ³ / ₁₆	315	135	183	90	32	140	150,3	139	172	15	95	260	22	27	M20	3/4
DKV120	6,1	57,15	2 ¹ / ₄	275	115	155	80	30	120	129	121	153	12,5	80	230	18	23	M16	5/8
DKV120	6,1	57,15	2 ¹ / ₄	275	115	155	80	30	120	129	121	153	12,5	80	230	18	23	M16	5/8
DKV120	6,1	57,15	2 ¹ / ₄	275	115	155	80	30	120	129	121	153	12,5	80	230	18	23	M16	5/8
DKV120	6,1	57,15	2 ¹ / ₄	275	115	155	80	30	120	129	121	153	12,5	80	230	18	23	M16	5/8
DKV140	9,3	57,15	2 ¹ / ₄	315	135	183	90	32	140	150,3	139	172	15	95	260	22	27	M20	3/4
DKV140	9,3	57,15	2 ¹ / ₄	315	135	183	90	32	140	150,3	139	172	15	95	260	22	27	M20	3/4
DKV140	9,3	57,15	2 ¹ / ₄	315	135	183	90	32	140	150,3	139	172	15	95	260	22	27	M20	3/4
DKV140	9,3	57,15	2 ¹ / ₄	315	135	183	90	32	140	150,3	139	172	15	95	260	22	27	M20	3/4
DKV140	9,3	57,15	2 ¹ / ₄	315	135	183	90	32	140	150,3	139	172	15	95	260	22	27	M20	3/4



Plummer block housings

SNV, split
For bearings with tapered bore and adapter sleeve

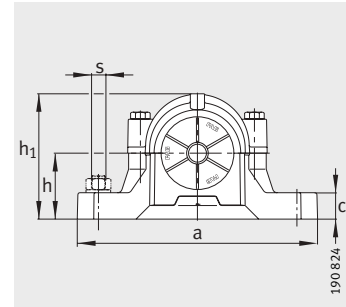
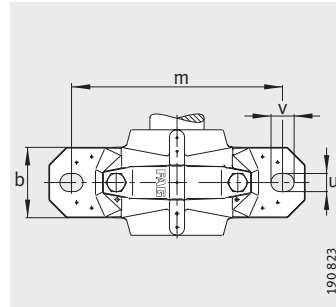

- ① Locating bearing
- ② Non-locating bearing

Dimension table (continued) · Dimensions in mm								
Designation								
Housing	Bearing	Adapter sleeve	Locating ring 2 pieces	Double lip seal	Labyrinth ring with round cord	Felt seal	V ring seal	Taconite seal
SNV120-L	1213-K-TVH-C3	H213	FRM120/14	DH513	TSV513	FSV513	DHV513	TCV513
SNV120-L	20213-K-TVP-C3	H213	FRM120/14	DH513	TSV513	FSV513	DHV513	TCV513
SNV120-L	2213-K-TVH-C3	H313	FRM120/10	DH513	TSV513	FSV513	DHV513	TCV513
SNV120-L	22213-E1-K	H313	FRM120/10	DH513	TSV513	FSV513	DHV513	TCV513
SNV140-L	1313-K-TVH-C3	H313	FRM140/12,5	DH613	TSV613	FSV613	DHV613	TCV613
SNV140-L	20313-K-MB-C3	H313	FRM140/12,5	DH613	TSV613	FSV613	DHV613	TCV613
SNV140-L	21313-E1-K	H313	FRM140/12,5	DH613	TSV613	FSV613	DHV613	TCV613
SNV140-L	2313-K-TVH-C3	H2313	FRM140/5	DH613	TSV613	FSV613	DHV613	TCV613
SNV140-L	22313-E1-K	H2313	FRM140/5	DH613	TSV613	FSV613	DHV613	TCV613
SNV120-L	1213-K-TVH-C3	H213X206	FRM120/14	DH513	TSV513	FSV513	DHV513	TCV513
SNV120-L	20213-K-TVP-C3	H213X206	FRM120/14	DH513	TSV513	FSV513	DHV513	TCV513
SNV120-L	2213-K-TVH-C3	H313X206	FRM120/10	DH513	TSV513	FSV513	DHV513	TCV513
SNV120-L	22213-E1-K	H313X206	FRM120/10	DH513	TSV513	FSV513	DHV513	TCV513
SNV140-L	1313-K-TVH-C3	H313X206	FRM140/12,5	DH613	TSV613	FSV613	DHV613	TCV613
SNV140-L	20313-K-MB-C3	H313X206	FRM140/12,5	DH613	TSV613	FSV613	DHV613	TCV613
SNV140-L	21313-E1-K	H313X206	FRM140/12,5	DH613	TSV613	FSV613	DHV613	TCV613
SNV140-L	2313-K-TVH-C3	H2313X206	FRM140/5	DH613	TSV613	FSV613	DHV613	TCV613
SNV140-L	22313-E1-K	H2313X206	FRM140/5	DH613	TSV613	FSV613	DHV613	TCV613
SNV130-L	1215-K-TVH-C3	H215X207	FRM130/15,5	DH515X207	TSV515X207	FSV515X207	DHV515X207	TCV515X207
SNV130-L	20215-K-TVP-C3	H215X207	FRM130/15,5	DH515X207	TSV515X207	FSV515X207	DHV515X207	TCV515X207
SNV130-L	2215-K-TVH-C3	H315X207	FRM130/12,5	DH515X207	TSV515X207	FSV515X207	DHV515X207	TCV515X207
SNV130-L	22215-E1-K	H315X207	FRM130/12,5	DH515X207	TSV515X207	FSV515X207	DHV515X207	TCV515X207
SNV160-L	1315-K-M-C3	H315X207	FRM160/14	DH615X207	TSV615X207	FSV615X207	DHV615X207	TCV615X207
SNV160-L	21315-E-1K	H315X207	FRM160/14	DH615X207	TSV615X207	FSV615X207	DHV615X207	TCV615X207
SNV160-L	2315-K-M-C3	H2315X207	FRM160/5	DH615X207	TSV615X207	FSV615X207	DHV615X207	TCV615X207
SNV160-L	22315-E1-K	H2315X207	FRM160/5	DH615X207	TSV615X207	FSV615X207	DHV615X207	TCV615X207
SNV130-L	1215-K-TVH-C3	H215X208	FRM130/15,5	DH515X207	TSV515X208	FSV515X208	DHV515X208	TCV515X208
SNV130-L	20215-K-TVP-C3	H215X208	FRM130/15,5	DH515X207	TSV515X208	FSV515X208	DHV515X208	TCV515X208
SNV130-L	2215-K-TVH-C3	H315X208	FRM130/12,5	DH515X207	TSV515X208	FSV515X208	DHV515X208	TCV515X208
SNV130-L	22215-E1-K	H315X208	FRM130/12,5	DH515X207	TSV515X208	FSV515X208	DHV515X208	TCV515X208
SNV160-L	1315-K-M-C3	H315X208	FRM160/14	DH615X207	TSV615X208	FSV615X208	DHV615X208	TCV615X208
SNV160-L	21315-E1-K	H315X208	FRM160/14	DH615X207	TSV615X208	FSV615X208	DHV615X208	TCV615X208
SNV160-L	2315-K-M-C3	H2315X208	FRM160/5	DH615X207	TSV615X208	FSV615X208	DHV615X208	TCV615X208
SNV160-L	22315-E1-K	H2315X208	FRM160/5	DH615X207	TSV615X208	FSV615X208	DHV615X208	TCV615X208

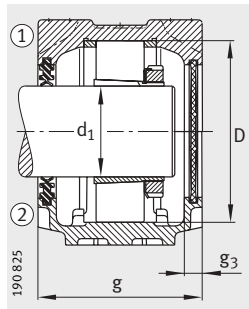

Double lip seal DH
Cover DKV

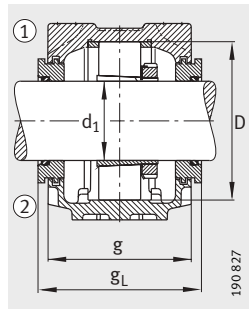

Labyrinth ring TSV

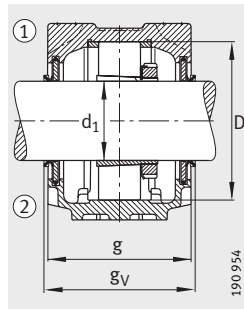

V ring seal DHV

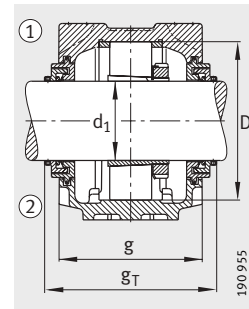

Taconite seal TCV

Cover	Mass m ≈kg	Dimensions																	
		Housing d ₁	a		g	h ₁	b	c	D	g _L	g _V	g _T	g ₃	h	m	u	v	s	
			mm	inch															mm
DKV120	6,1	60	–	275	115	155	80	30	120	129	121	153	12,5	80	230	18	23	M16	5/8
DKV120	6,1	60	–	275	115	155	80	30	120	129	121	153	12,5	80	230	18	23	M16	5/8
DKV120	6,1	60	–	275	115	155	80	30	120	129	121	153	12,5	80	230	18	23	M16	5/8
DKV120	6,1	60	–	275	115	155	80	30	120	129	121	153	12,5	80	230	18	23	M16	5/8
DKV140	9,3	60	–	315	135	183	90	32	140	150,3	139	172	15	95	260	22	27	M20	3/4
DKV140	9,3	60	–	315	135	183	90	32	140	150,3	139	172	15	95	260	22	27	M20	3/4
DKV140	9,3	60	–	315	135	183	90	32	140	150,3	139	172	15	95	260	22	27	M20	3/4
DKV140	9,3	60	–	315	135	183	90	32	140	150,3	139	172	15	95	260	22	27	M20	3/4
DKV140	9,3	60	–	315	135	183	90	32	140	150,3	139	172	15	95	260	22	27	M20	3/4
DKV120	6,1	60,325	2 ³ / ₈	275	115	155	80	30	120	129	121	153	12,5	80	230	18	23	M16	5/8
DKV120	6,1	60,325	2 ³ / ₈	275	115	155	80	30	120	129	121	153	12,5	80	230	18	23	M16	5/8
DKV120	6,1	60,325	2 ³ / ₈	275	115	155	80	30	120	129	121	153	12,5	80	230	18	23	M16	5/8
DKV120	6,1	60,325	2 ³ / ₈	275	115	155	80	30	120	129	121	153	12,5	80	230	18	23	M16	5/8
DKV140	9,3	60,325	2 ³ / ₈	315	135	183	90	32	140	150,3	139	172	15	95	260	22	27	M20	3/4
DKV140	9,3	60,325	2 ³ / ₈	315	135	183	90	32	140	150,3	139	172	15	95	260	22	27	M20	3/4
DKV140	9,3	60,325	2 ³ / ₈	315	135	183	90	32	140	150,3	139	172	15	95	260	22	27	M20	3/4
DKV140	9,3	60,325	2 ³ / ₈	315	135	183	90	32	140	150,3	139	172	15	95	260	22	27	M20	3/4
DKV140	9,3	60,325	2 ³ / ₈	315	135	183	90	32	140	150,3	139	172	15	95	260	22	27	M20	3/4
DKV130	6,8	61,913	2 ⁷ / ₁₆	280	120	161	80	30	130	134	126	158	12,5	80	230	18	23	M16	5/8
DKV130	6,8	61,913	2 ⁷ / ₁₆	280	120	161	80	30	130	134	126	158	12,5	80	230	18	23	M16	5/8
DKV130	6,8	61,913	2 ⁷ / ₁₆	280	120	161	80	30	130	134	126	158	12,5	80	230	18	23	M16	5/8
DKV130	6,8	61,913	2 ⁷ / ₁₆	280	120	161	80	30	130	134	126	158	12,5	80	230	18	23	M16	5/8
DKV160	12,8	61,913	2 ⁷ / ₁₆	345	145	201	100	35	160	160,3	149	182	15	100	290	22	27	M20	3/4
DKV160	12,8	61,913	2 ⁷ / ₁₆	345	145	201	100	35	160	160,3	149	182	15	100	290	22	27	M20	3/4
DKV160	12,8	61,913	2 ⁷ / ₁₆	345	145	201	100	35	160	160,3	149	182	15	100	290	22	27	M20	3/4
DKV160	12,8	61,913	2 ⁷ / ₁₆	345	145	201	100	35	160	160,3	149	182	15	100	290	22	27	M20	3/4
DKV130	6,8	63,5	2 ¹ / ₂	280	120	161	80	30	130	134	126	158	12,5	80	230	18	23	M16	5/8
DKV130	6,8	63,5	2 ¹ / ₂	280	120	161	80	30	130	134	126	158	12,5	80	230	18	23	M16	5/8
DKV130	6,8	63,5	2 ¹ / ₂	280	120	161	80	30	130	134	126	158	12,5	80	230	18	23	M16	5/8
DKV130	6,8	63,5	2 ¹ / ₂	280	120	161	80	30	130	134	126	158	12,5	80	230	18	23	M16	5/8
DKV160	12,8	63,5	2 ¹ / ₂	345	145	201	100	35	160	160,3	149	182	15	100	290	22	27	M20	3/4
DKV160	12,8	63,5	2 ¹ / ₂	345	145	201	100	35	160	160,3	149	182	15	100	290	22	27	M20	3/4
DKV160	12,8	63,5	2 ¹ / ₂	345	145	201	100	35	160	160,3	149	182	15	100	290	22	27	M20	3/4
DKV160	12,8	63,5	2 ¹ / ₂	345	145	201	100	35	160	160,3	149	182	15	100	290	22	27	M20	3/4



Plummer block housings

SNV, split
For bearings with tapered bore and adapter sleeve

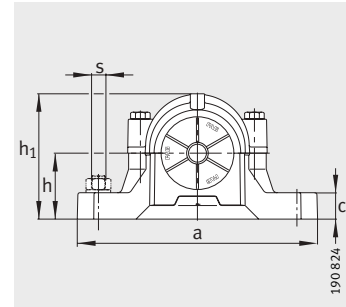
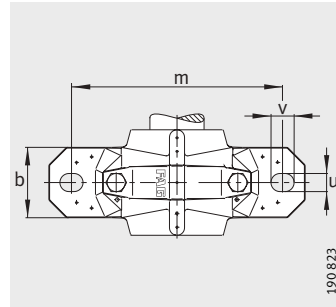

- ① Locating bearing
- ② Non-locating bearing

Dimension table (continued) · Dimensions in mm								
Designation								
Housing	Bearing	Adapter sleeve	Locating ring 2 pieces	Double lip seal	Labyrinth ring with round cord	Felt seal	V ring seal	Taconite seal
SNV130-L	1215-K-TVH-C3	H215	FRM130/15,5	DH515	TSV515	FSV515	DHV515	TCV515
SNV130-L	20215-K-TVP-C3	H215	FRM130/15,5	DH515	TSV515	FSV515	DHV515	TCV515
SNV130-L	2215-K-TVH-C3	H315	FRM130/12,5	DH515	TSV515	FSV515	DHV515	TCV515
SNV130-L	22215-E1-K	H315	FRM130/12,5	DH515	TSV515	FSV515	DHV515	TCV515
SNV160-L	1315-K-M-C3	H315	FRM160/14	DH615	TSV615	FSV615	DHV615	TCV615
SNV160-L	21315-E1-K	H315	FRM160/14	DH615	TSV615	FSV615	DHV615	TCV615
SNV160-L	2315-K-M-C3	H2315	FRM160/5	DH615	TSV615	FSV615	DHV615	TCV615
SNV160-L	22315-E1-K	H2315	FRM160/5	DH615	TSV615	FSV615	DHV615	TCV615
SNV130-L	1215-K-TVH-C3	H215X210	FRM130/15,5	DH515	TSV515X210	FSV515X210	DHV515X210	TCV515X210
SNV130-L	20215-K-TVP-C3	H215X210	FRM130/15,5	DH515	TSV515X210	FSV515X210	DHV515X210	TCV515X210
SNV130-L	2215-K-TVH-C3	H315X210	FRM130/12,5	DH515	TSV515X210	FSV515X210	DHV515X210	TCV515X210
SNV130-L	22215-E1-K	H315X210	FRM130/12,5	DH515	TSV515X210	FSV515X210	DHV515X210	TCV515X210
SNV160-L	1315-K-M-C3	H315X210	FRM160/14	DH615	TSV615X210	FSV615X210	DHV615X210	TCV615X210
SNV160-L	21315-E1-K	H315X210	FRM160/14	DH615	TSV615X210	FSV615X210	DHV615X210	TCV615X210
SNV160-L	2315-K-M-C3	H2315X210	FRM160/5	DH615	TSV615X210	FSV615X210	DHV615X210	TCV615X210
SNV160-L	22315-E1-K	H2315X210	FRM160/5	DH615	TSV615X210	FSV615X210	DHV615X210	TCV615X210
SNV140-L	1216-K-TVH-C3	H216X211	FRM140/16	DH516X211	TSV516X211	FSV516X211	DHV516X211	TCV516X211
SNV140-L	20216-K-TVP-C3	H216X211	FRM140/16	DH516X211	TSV516X211	FSV516X211	DHV516X211	TCV516X211
SNV140-L	2216-K-TVH-C3	H316X211	FRM140/12,5	DH516X211	TSV516X211	FSV516X211	DHV516X211	TCV516X211
SNV140-L	22216-E1-K	H316X211	FRM140/12,5	DH516X211	TSV516X211	FSV516X211	DHV516X211	TCV516X211
SNV170-L	1316-K-M-C3	H316X211	FRM170/14,5	DH616X211	TSV616X211	FSV616X211	DHV616X211	TCV616X211
SNV170-L	21316-E1-K	H316X211	FRM170/14,5	DH616X211	TSV616X211	FSV616X211	DHV616X211	TCV616X211
SNV170-L	2316-K-M-C3	H2316X211	FRM170/5	DH616X211	TSV616X211	FSV616X211	DHV616X211	TCV616X211
SNV170-L	22316-E1-K	H2316X211	FRM170/5	DH616X211	TSV616X211	FSV616X211	DHV616X211	TCV616X211
SNV140-L	1216-K-TVH-C3	H216X212	FRM140/16	DH516	TSV516	FSV516	DHV516	TCV516
SNV140-L	20216-K-TVP-C3	H216X212	FRM140/16	DH516	TSV516	FSV516	DHV516	TCV516
SNV140-L	2216-K-TVH-C3	H316X212	FRM140/12,5	DH516	TSV516	FSV516	DHV516	TCV516
SNV140-L	22216-E1-K	H316X212	FRM140/12,5	DH516	TSV516	FSV516	DHV516	TCV516
SNV170-L	1316-K-M-C3	H316X212	FRM170/14,5	DH616	TSV616	FSV616	DHV616	TCV616
SNV170-L	21316-E1-K	H316X212	FRM170/14,5	DH616	TSV616	FSV616	DHV616	TCV616
SNV170-L	2316-K-M-C3	H2316X212	FRM170/5	DH616	TSV616	FSV616	DHV616	TCV616
SNV170-L	22316-E1-K	H2316X212	FRM170/5	DH616	TSV616	FSV616	DHV616	TCV616

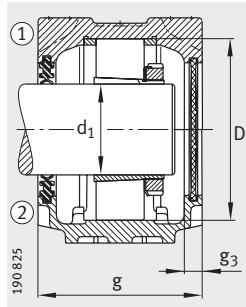

Double lip seal DH
Cover DKV

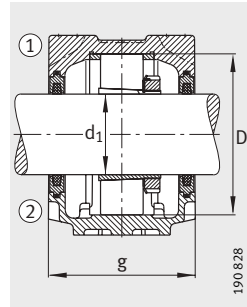

Felt seal FSV

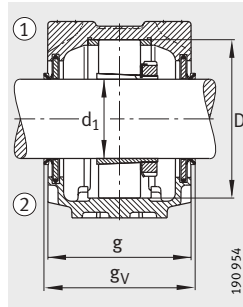

V ring seal DHV

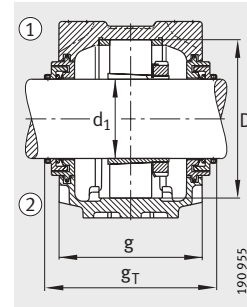

Taconite seal TCV

Cover	Mass m ≈kg	Dimensions																	
		Housing d ₁	a	g	h ₁	b	c	D	g _L	g _V	g _T	g ₃	h	m	u	v	s		
																		mm	inch
DKV130	6,8	65	–	280	120	161	80	30	130	134	126	158	12,5	80	230	18	23	M16	5/8
DKV130	6,8	65	–	280	120	161	80	30	130	134	126	158	12,5	80	230	18	23	M16	5/8
DKV130	6,8	65	–	280	120	161	80	30	130	134	126	158	12,5	80	230	18	23	M16	5/8
DKV130	6,8	65	–	280	120	161	80	30	130	134	126	158	12,5	80	230	18	23	M16	5/8
DKV160	12,8	65	–	345	145	201	100	35	160	160,3	149	182	15	100	290	22	27	M20	3/4
DKV160	12,8	65	–	345	145	201	100	35	160	160,3	149	182	15	100	290	22	27	M20	3/4
DKV160	12,8	65	–	345	145	201	100	35	160	160,3	149	182	15	100	290	22	27	M20	3/4
DKV160	12,8	65	–	345	145	201	100	35	160	160,3	149	182	15	100	290	22	27	M20	3/4
DKV130	6,8	66,675	2 ⁵ / ₈	280	120	161	80	30	130	134	126	158	12,5	80	230	18	23	M16	5/8
DKV130	6,8	66,675	2 ⁵ / ₈	280	120	161	80	30	130	134	126	158	12,5	80	230	18	23	M16	5/8
DKV130	6,8	66,675	2 ⁵ / ₈	280	120	161	80	30	130	134	126	158	12,5	80	230	18	23	M16	5/8
DKV130	6,8	66,675	2 ⁵ / ₈	280	120	161	80	30	130	134	126	158	12,5	80	230	18	23	M16	5/8
DKV160	12,8	66,675	2 ⁵ / ₈	345	145	201	100	35	160	160,3	149	182	15	100	290	22	27	M20	3/4
DKV160	12,8	66,675	2 ⁵ / ₈	345	145	201	100	35	160	160,3	149	182	15	100	290	22	27	M20	3/4
DKV160	12,8	66,675	2 ⁵ / ₈	345	145	201	100	35	160	160,3	149	182	15	100	290	22	27	M20	3/4
DKV160	12,8	66,675	2 ⁵ / ₈	345	145	201	100	35	160	160,3	149	182	15	100	290	22	27	M20	3/4
DKV140	9,3	68,263	2 ¹¹ / ₁₆	315	135	183	90	32	140	150,3	143	176	15	95	260	22	27	M20	3/4
DKV140	9,3	68,263	2 ¹¹ / ₁₆	315	135	183	90	32	140	150,3	143	176	15	95	260	22	27	M20	3/4
DKV140	9,3	68,263	2 ¹¹ / ₁₆	315	135	183	90	32	140	150,3	143	176	15	95	260	22	27	M20	3/4
DKV140	9,3	68,263	2 ¹¹ / ₁₆	315	135	183	90	32	140	150,3	143	176	15	95	260	22	27	M20	3/4
DKV170	14,4	68,263	2 ¹¹ / ₁₆	345	150	219	100	35	170	167,3	158	193	16	112	290	22	27	M20	3/4
DKV170	14,4	68,263	2 ¹¹ / ₁₆	345	150	219	100	35	170	167,3	158	193	16	112	290	22	27	M20	3/4
DKV170	14,4	68,263	2 ¹¹ / ₁₆	345	150	219	100	35	170	167,3	158	193	16	112	290	22	27	M20	3/4
DKV170	14,4	68,263	2 ¹¹ / ₁₆	345	150	219	100	35	170	167,3	158	193	16	112	290	22	27	M20	3/4
DKV140	9,3	69,85	2 ³ / ₄	315	135	183	90	32	140	150,3	143	176	15	95	260	22	27	M20	3/4
DKV140	9,3	69,85	2 ³ / ₄	315	135	183	90	32	140	150,3	143	176	15	95	260	22	27	M20	3/4
DKV140	9,3	69,85	2 ³ / ₄	315	135	183	90	32	140	150,3	143	176	15	95	260	22	27	M20	3/4
DKV140	9,3	69,85	2 ³ / ₄	315	135	183	90	32	140	150,3	143	176	15	95	260	22	27	M20	3/4
DKV170	14,4	69,85	2 ³ / ₄	345	150	219	100	35	170	167,3	158	193	16	112	290	22	27	M20	3/4
DKV170	14,4	69,85	2 ³ / ₄	345	150	219	100	35	170	167,3	158	193	16	112	290	22	27	M20	3/4
DKV170	14,4	69,85	2 ³ / ₄	345	150	219	100	35	170	167,3	158	193	16	112	290	22	27	M20	3/4
DKV170	14,4	69,85	2 ³ / ₄	345	150	219	100	35	170	167,3	158	193	16	112	290	22	27	M20	3/4



Plummer block housings

SNV, split
For bearings with tapered bore and adapter sleeve

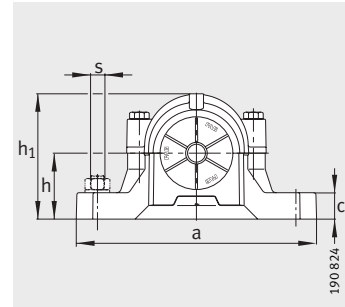
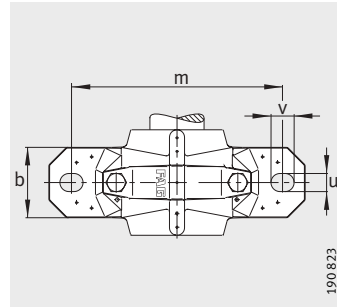

- ① Locating bearing
- ② Non-locating bearing

Dimension table (continued) · Dimensions in mm								
Designation								
Housing	Bearing	Adapter sleeve	Locating ring 2 pieces	Double lip seal	Labyrinth ring with round cord	Felt seal	V ring seal	Taconite seal
SNV140-L	1216-K-TVH-C3	H216	FRM140/16	DH516	TSV516	FSV516	DHV516	TCV516
SNV140-L	20216-K-TVP-C3	H216	FRM140/16	DH516	TSV516	FSV516	DHV516	TCV516
SNV140-L	2216-K-TVH-C3	H316	FRM140/12,5	DH516	TSV516	FSV516	DHV516	TCV516
SNV140-L	22216-E1-K	H316	FRM140/12,5	DH516	TSV516	FSV516	DHV516	TCV516
SNV170-L	1316-K-M-C3	H316	FRM170/14,5	DH616	TSV616	FSV616	DHV616	TCV616
SNV170-L	21316-E1-K	H316	FRM170/14,5	DH616	TSV616	FSV616	DHV616	TCV616
SNV170-L	2316-K-M-C3	H2316	FRM170/5	DH616	TSV616	FSV616	DHV616	TCV616
SNV170-L	22316-E1-K	H2316	FRM170/5	DH616	TSV616	FSV616	DHV616	TCV616
SNV140-L	1216-K-TVH-C3	H216X214	FRM140/16	DH516X214	TSV516X214	FSV516X214	DHV516X214	TCV516X214
SNV140-L	20216-K-TVP-C3	H216X214	FRM140/16	DH516X214	TSV516X214	FSV516X214	DHV516X214	TCV516X214
SNV140-L	2216-K-TVH-C3	H316X214	FRM140/12,5	DH516X214	TSV516X214	FSV516X214	DHV516X214	TCV516X214
SNV140-L	22216-E1-K	H316X214	FRM140/12,5	DH516X214	TSV516X214	FSV516X214	DHV516X214	TCV516X214
SNV170-L	1316-K-M-C3	H316X214	FRM170/14,5	DH616X214	TSV616X214	FSV616X214	DHV616X214	TCV616X214
SNV170-L	21316-E1-K	H316X214	FRM170/14,5	DH616X214	TSV616X214	FSV616X214	DHV616X214	TCV616X214
SNV170-L	2316-K-M-C3	H2316X214	FRM170/5	DH616X214	TSV616X214	FSV616X214	DHV616X214	TCV616X214
SNV170-L	22316-E1-K	H2316X214	FRM170/5	DH616X214	TSV616X214	FSV616X214	DHV616X214	TCV616X214
SNV150-L	1217-K-TVH-C3	H217X215	FRM150/16,5	DH517	TSV517	FSV517	DHV517	TCV517
SNV150-L	20217-K-MB-C3	H217X215	FRM150/16,5	DH517	TSV517	FSV517	DHV517	TCV517
SNV150-L	2217-K-M-C3	H317X215	FRM150/12,5	DH517	TSV517	FSV517	DHV517	TCV517
SNV150-L	22217-E1-K	H317X215	FRM150/12,5	DH517	TSV517	FSV517	DHV517	TCV517
SNV180-L	1317-K-M-C3	H317X215	FRM180/14,5	DH617	TSV617	FSV617	DHV617	TCV617
SNV180-L	21317-E1-K	H317X215	FRM180/14,5	DH617	TSV617	FSV617	DHV617	TCV617
SNV180-L	2317-K-M-C3	H2317X215	FRM180/5	DH617	TSV617	FSV617	DHV617	TCV617
SNV180-L	22317-E1-K	H2317X215	FRM180/5	DH617	TSV617	FSV617	DHV617	TCV617

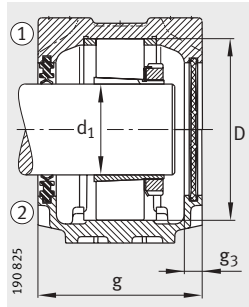

Double lip seal DH
Cover DKV

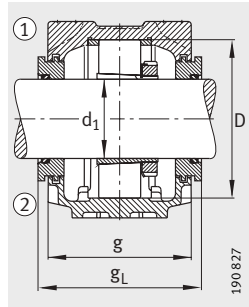

Labyrinth ring TSV

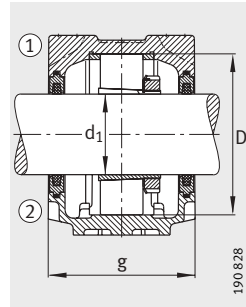

Felt seal FSV

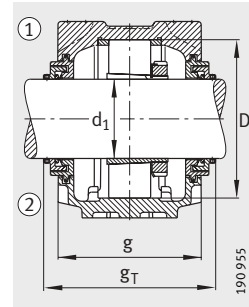

Taconite seal TCV

Cover	Mass m ≈kg	Dimensions																	
		Housing d ₁	a	g	h ₁	b	c	D	g _L	g _v	g _T	g ₃	h	m	u	v	s		
																		mm	inch
DKV140	9,3	70	–	315	135	183	90	32	140	150,3	143	176	15	95	260	22	27	M20	3/4
DKV140	9,3	70	–	315	135	183	90	32	140	150,3	143	176	15	95	260	22	27	M20	3/4
DKV140	9,3	70	–	315	135	183	90	32	140	150,3	143	176	15	95	260	22	27	M20	3/4
DKV140	9,3	70	–	315	135	183	90	32	140	150,3	143	176	15	95	260	22	27	M20	3/4
DKV170	14,4	70	–	345	150	219	100	35	170	167,3	158	193	16	112	290	22	27	M20	3/4
DKV170	14,4	70	–	345	150	219	100	35	170	167,3	158	193	16	112	290	22	27	M20	3/4
DKV170	14,4	70	–	345	150	219	100	35	170	167,3	158	193	16	112	290	22	27	M20	3/4
DKV170	14,4	70	–	345	150	219	100	35	170	167,3	158	193	16	112	290	22	27	M20	3/4
DKV140	9,3	73,025	2 ⁷ / ₈	315	135	183	90	32	140	150,3	143	176	15	95	260	22	27	M20	3/4
DKV140	9,3	73,025	2 ⁷ / ₈	315	135	183	90	32	140	150,3	143	176	15	95	260	22	27	M20	3/4
DKV140	9,3	73,025	2 ⁷ / ₈	315	135	183	90	32	140	150,3	143	176	15	95	260	22	27	M20	3/4
DKV140	9,3	73,025	2 ⁷ / ₈	315	135	183	90	32	140	150,3	143	176	15	95	260	22	27	M20	3/4
DKV170	14,4	73,025	2 ⁷ / ₈	345	150	219	100	35	170	167,3	158	193	16	112	290	22	27	M20	3/4
DKV170	14,4	73,025	2 ⁷ / ₈	345	150	219	100	35	170	167,3	158	193	16	112	290	22	27	M20	3/4
DKV170	14,4	73,025	2 ⁷ / ₈	345	150	219	100	35	170	167,3	158	193	16	112	290	22	27	M20	3/4
DKV170	14,4	73,025	2 ⁷ / ₈	345	150	219	100	35	170	167,3	158	193	16	112	290	22	27	M20	3/4
DKV150	9,9	74,613	2 ¹⁵ / ₁₆	320	140	189	90	32	150	155,3	148	181	15	95	260	22	27	M20	3/4
DKV150	9,9	74,613	2 ¹⁵ / ₁₆	320	140	189	90	32	150	155,3	148	181	15	95	260	22	27	M20	3/4
DKV150	9,9	74,613	2 ¹⁵ / ₁₆	320	140	189	90	32	150	155,3	148	181	15	95	260	22	27	M20	3/4
DKV150	9,9	74,613	2 ¹⁵ / ₁₆	320	140	189	90	32	150	155,3	148	181	15	95	260	22	27	M20	3/4
DKV180	17	74,613	2 ¹⁵ / ₁₆	380	160	223	110	40	180	177,3	168	203	16	112	320	26	32	M24	7/8
DKV180	17	74,613	2 ¹⁵ / ₁₆	380	160	223	110	40	180	177,3	168	203	16	112	320	26	32	M24	7/8
DKV180	17	74,613	2 ¹⁵ / ₁₆	380	160	223	110	40	180	177,3	168	203	16	112	320	26	32	M24	7/8
DKV180	17	74,613	2 ¹⁵ / ₁₆	380	160	223	110	40	180	177,3	168	203	16	112	320	26	32	M24	7/8



Plummer block housings

SNV, split
For bearings with tapered bore and adapter sleeve

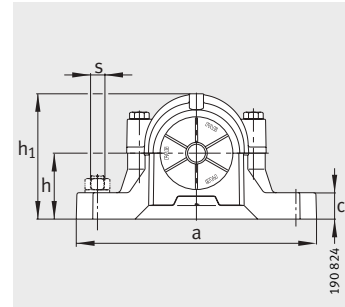
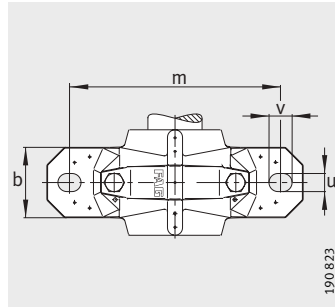

- ① Locating bearing
- ② Non-locating bearing

Dimension table (continued) - Dimensions in mm

Designation								
Housing	Bearing	Adapter sleeve	Locating ring 2 pieces	Double lip seal	Labyrinth ring with round cord	Felt seal	V ring seal	Taconite seal
SNV150-L	1217-K-TVH-C3	H217	FRM150/16,5	DH517	TSV517	FSV517	DHV517	TCV517
SNV150-L	20217-K-MB-C3	H217	FRM150/16,5	DH517	TSV517	FSV517	DHV517	TCV517
SNV150-L	2217-K-M-C3	H317	FRM150/12,5	DH517	TSV517	FSV517	DHV517	TCV517
SNV150-L	22217-E1-K	H317	FRM150/12,5	DH517	TSV517	FSV517	DHV517	TCV517
SNV180-L	1317-K-M-C3	H317	FRM180/14,5	DH617	TSV617	FSV617	DHV617	TCV617
SNV180-L	21317-E1-K	H317	FRM180/14,5	DH617	TSV617	FSV617	DHV617	TCV617
SNV180-L	2317-K-M-C3	H2317	FRM180/5	DH617	TSV617	FSV617	DHV617	TCV617
SNV180-L	22317-E1-K	H2317	FRM180/5	DH617	TSV617	FSV617	DHV617	TCV617
SNV150-L	1217-K-TVH-C3	H217X300	FRM150/16,5	DH517	TSV517X300	FSV517X300	DHV517X300	TCV517X300
SNV150-L	20217-K-MB-C3	H217X300	FRM150/16,5	DH517	TSV517X300	FSV517X300	DHV517X300	TCV517X300
SNV150-L	2217-K-M-C3	H317X300	FRM150/12,5	DH517	TSV517X300	FSV517X300	DHV517X300	TCV517X300
SNV150-L	22217-E1-K	H317X300	FRM150/12,5	DH517	TSV517X300	FSV517X300	DHV517X300	TCV517X300
SNV180-L	1317-K-M-C3	H317X300	FRM180/14,5	DH617	TSV617X300	FSV617X300	DHV617X300	TCV617X300
SNV180-L	21317-E1-K	H317X300	FRM180/14,5	DH617	TSV617X300	FSV617X300	DHV617X300	TCV617X300
SNV180-L	2317-K-M-C3	H2317X300	FRM180/5	DH617	TSV617X300	FSV617X300	DHV617X300	TCV617X300
SNV180-L	22317-E1-K	H2317X300	FRM180/5	DH617	TSV617X300	FSV617X300	DHV617X300	TCV617X300
SNV160-L	1218-K-TVH-C3	H218X302	FRM160/17,5	DH518	TSV518X302	FSV518	DHV518	TCV518X302
SNV160-L	20218-K-MB-C3	H218X302	FRM160/17,5	DH518	TSV518X302	FSV518	DHV518	TCV518X302
SNV160-L	2218-K-TVH-C3	H318X302	FRM160/12,5	DH518	TSV518X302	FSV518	DHV518	TCV518X302
SNV160-L	22218-E1-K	H318X302	FRM160/12,5	DH518	TSV518X302	FSV518	DHV518	TCV518X302
SNV160-L	23218-E1-K-TVPB	H2318X302	FRM160/6,3	DH518	TSV518X302	FSV518	DHV518	TCV518X302
SNV190-L	1318-K-M-C3	H318X302	FRM190/15,5	DH518	TSV518X302	FSV518	DHV518	TCV518X302
SNV190-L	20318-K-MB-C3	H318X302	FRM190/15,5	DH518	TSV518X302	FSV518	DHV518	TCV518X302
SNV190-L	21318-E1-K	H318X302	FRM190/15,5	DH518	TSV518X302	FSV518	DHV518	TCV518X302
SNV190-L	2318-K-M-C3	H2318X302	FRM190/5	DH518	TSV518X302	FSV518	DHV518	TCV518X302
SNV190-L	22318-E1-K	H2318X302	FRM190/5	DH518	TSV518X302	FSV518	DHV518	TCV518X302

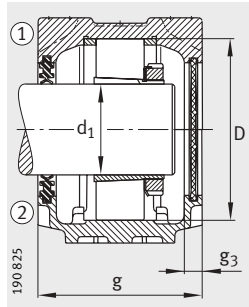

Double lip seal DH
Cover DKV

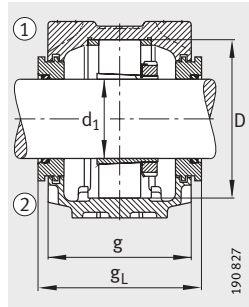

Labyrinth ring TSV

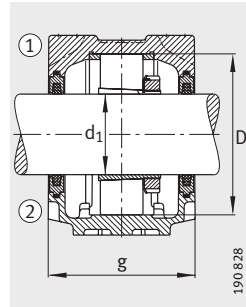

Felt seal FSV

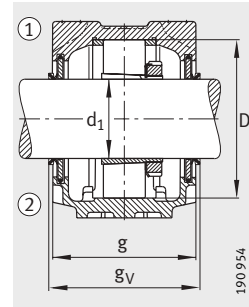

V ring seal DHV

Cover	Mass m Housing ≈kg	Dimensions																	
		d ₁		a	g	h ₁	b	c	D	g _L	g _V	g _T	g ₃	h	m	u	v	s	
		mm	inch															mm	inch
DKV150	9,9	75	–	320	140	189	90	32	150	155,3	148	181	15	95	260	22	27	M20	3/4
DKV150	9,9	75	–	320	140	189	90	32	150	155,3	148	181	15	95	260	22	27	M20	3/4
DKV150	9,9	75	–	320	140	189	90	32	150	155,3	148	181	15	95	260	22	27	M20	3/4
DKV150	9,9	75	–	320	140	189	90	32	150	155,3	148	181	15	95	260	22	27	M20	3/4
DKV180	17	75	–	380	160	223	110	40	180	177,3	168	203	16	112	320	26	32	M24	7/8
DKV180	17	75	–	380	160	223	110	40	180	177,3	168	203	16	112	320	26	32	M24	7/8
DKV180	17	75	–	380	160	223	110	40	180	177,3	168	203	16	112	320	26	32	M24	7/8
DKV180	17	75	–	380	160	223	110	40	180	177,3	168	203	16	112	320	26	32	M24	7/8
DKV150	9,9	76,2	3	320	140	189	90	32	150	155,3	148	181	15	95	260	22	27	M20	3/4
DKV150	9,9	76,2	3	320	140	189	90	32	150	155,3	148	181	15	95	260	22	27	M20	3/4
DKV150	9,9	76,2	3	320	140	189	90	32	150	155,3	148	181	15	95	260	22	27	M20	3/4
DKV150	9,9	76,2	3	320	140	189	90	32	150	155,3	148	181	15	95	260	22	27	M20	3/4
DKV180	17	76,2	3	380	160	223	110	40	180	177,3	168	203	16	112	320	26	32	M24	7/8
DKV180	17	76,2	3	380	160	223	110	40	180	177,3	168	203	16	112	320	26	32	M24	7/8
DKV180	17	76,2	3	380	160	223	110	40	180	177,3	168	203	16	112	320	26	32	M24	7/8
DKV180	17	76,2	3	380	160	223	110	40	180	177,3	168	203	16	112	320	26	32	M24	7/8
DKV160	12,8	79,375	3 ¹ / ₈	345	145	201	100	35	160	160,3	153	186	15	100	290	22	27	M20	3/4
DKV160	12,8	79,375	3 ¹ / ₈	345	145	201	100	35	160	160,3	153	186	15	100	290	22	27	M20	3/4
DKV160	12,8	79,375	3 ¹ / ₈	345	145	201	100	35	160	160,3	153	186	15	100	290	22	27	M20	3/4
DKV160	12,8	79,375	3 ¹ / ₈	345	145	201	100	35	160	160,3	153	186	15	100	290	22	27	M20	3/4
DKV160	22	79,375	3 ¹ / ₈	380	155	229	110	40	190	170,3	163	178	15	112	320	26	32	M24	7/8
DKV160	22	79,375	3 ¹ / ₈	380	155	229	110	40	190	170,3	163	178	15	112	320	26	32	M24	7/8
DKV160	22	79,375	3 ¹ / ₈	380	155	229	110	40	190	170,3	163	178	15	112	320	26	32	M24	7/8
DKV160	22	79,375	3 ¹ / ₈	380	155	229	110	40	190	170,3	163	178	15	112	320	26	32	M24	7/8
DKV160	22	79,375	3 ¹ / ₈	380	155	229	110	40	190	170,3	163	178	15	112	320	26	32	M24	7/8



Plummer block housings

SNV, split
For bearings with tapered bore and adapter sleeve

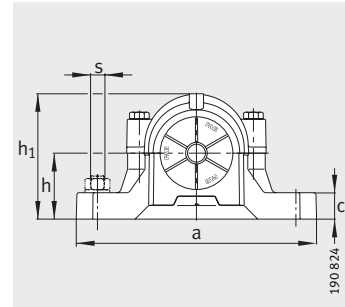
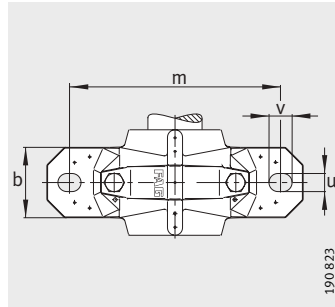

- ① Locating bearing
- ② Non-locating bearing

Dimension table (continued) · Dimensions in mm								
Designation								
Housing	Bearing	Adapter sleeve	Locating ring 2 pieces	Double lip seal	Labyrinth ring with round cord	Felt seal	V ring seal	Taconite seal
SNV160-L	1218-K-TVH-C3	H218	FRM160/17,5	DH518	TSV518	FSV518	DHV518	TCV518
SNV160-L	20218-K-MB-C3	H218	FRM160/17,5	DH518	TSV518	FSV518	DHV518	TCV518
SNV160-L	2218-K-TVH-C3	H318	FRM160/12,5	DH518	TSV518	FSV518	DHV518	TCV518
SNV160-L	22218-E1-K	H318	FRM160/12,5	DH518	TSV518	FSV518	DHV518	TCV518
SNV160-L	23218-E1-K-TVPB	H2318	FRM160/6,3	DH518	TSV518	FSV518	DHV518	TCV518
SNV190-L	1318-K-M-C3	H318	FRM190/15,5	DH518	TSV518	FSV518	DHV518	TCV518
SNV190-L	20318K-MB-C3	H318	FRM190/15,5	DH518	TSV518	FSV518	DHV518	TCV518
SNV190-L	21318-E1-K	H318	FRM190/15,5	DH518	TSV518	FSV518	DHV518	TCV518
SNV190-L	2318-K-M-C3	H2318	FRM190/5	DH518	TSV518	FSV518	DHV518	TCV518
SNV190-L	22318-E1-K	H2318	FRM190/5	DH518	TSV518	FSV518	DHV518	TCV518
SNV160-L	1218-K-TVH-C3	H218X303	FRM160/17,5	DH518	TSV518X303	FSV518X303	DHV518X303	TCV518X303
SNV160-L	20218-K-MB-C3	H218X303	FRM160/17,5	DH518	TSV518X303	FSV518X303	DHV518X303	TCV518X303
SNV160-L	2218-K-TVH-C3	H318X303	FRM160/12,5	DH518	TSV518X303	FSV518X303	DHV518X303	TCV518X303
SNV160-L	22218-E1-K	H318X303	FRM160/12,5	DH518	TSV518X303	FSV518X303	DHV518X303	TCV518X303
SNV160-L	23218-E1-K-TVPB	H2318X303	FRM160/6,3	DH518	TSV518X303	FSV518X303	DHV518X303	TCV518X303
SNV190-L	1318-K-M-C3	H318X303	FRM190/15,5	DH518	TSV518X303	FSV518X303	DHV518X303	TCV518X303
SNV190-L	20318-K-MB-C3	H318X303	FRM190/15,5	DH518	TSV518X303	FSV518X303	DHV518X303	TCV518X303
SNV190-L	21318-E1-K	H318X303	FRM190/15,5	DH518	TSV518X303	FSV518X303	DHV518X303	TCV518X303
SNV190-L	2318-K-M-C3	H2318X303	FRM190/5	DH518	TSV518X303	FSV518X303	DHV518X303	TCV518X303
SNV190-L	22318-E1-K	H2318X303	FRM190/5	DH518	TSV518X303	FSV518X303	DHV518X303	TCV518X303
SNV160-L	1218-K-TVH-C3	H218X304	FRM160/17,5	DH518X304	TSV518X304	FSV518X304	DHV518X304	TCV518X304
SNV160-L	20218-K-MB-C3	H218X304	FRM160/17,5	DH518X304	TSV518X304	FSV518X304	DHV518X304	TCV518X304
SNV160-L	2218-K-TVH-C3	H318X304	FRM160/12,5	DH518X304	TSV518X304	FSV518X304	DHV518X304	TCV518X304
SNV160-L	22218-E1-K	H318X304	FRM160/12,5	DH518X304	TSV518X304	FSV518X304	DHV518X304	TCV518X304
SNV160-L	23218-E1-K-TVPB	H2318X304	FRM160/6,3	DH518X304	TSV518X304	FSV518X304	DHV518X304	TCV518X304
SNV190-L	1318-K-M-C3	H318X304	FRM190/15,5	DH518X304	TSV518X304	FSV518X304	DHV518X304	TCV518X304
SNV190-L	20318-K-MB-C3	H318X304	FRM190/15,5	DH518X304	TSV518X304	FSV518X304	DHV518X304	TCV518X304
SNV190-L	21318-E1-K	H318X304	FRM190/15,5	DH518X304	TSV518X304	FSV518X304	DHV518X304	TCV518X304
SNV190-L	2318-K-M-C3	H2318X304	FRM190/5	DH518X304	TSV518X304	FSV518X304	DHV518X304	TCV518X304
SNV190-L	22318-E1-K	H2318X304	FRM190/5	DH518X304	TSV518X304	FSV518X304	DHV518X304	TCV518X304

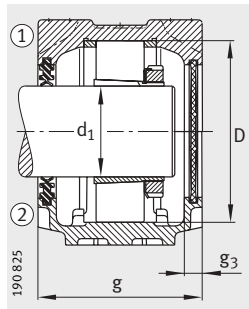

Double lip seal DH
Cover DKV

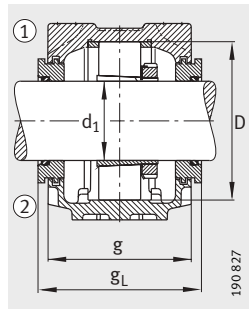

Labyrinth ring TSV

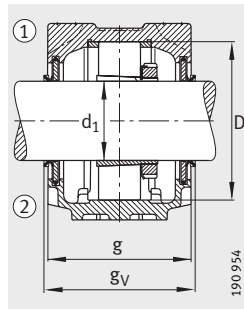

V ring seal DHV

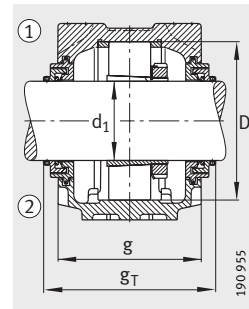

Taconite seal TCV

Cover	Mass m ≈kg	Dimensions																		
		Housing		d ₁	a	g	h ₁	b	c	D	g _L	g _V	g _T	g ₃	h	m	u	v	s	
		mm	inch																mm	inch
DKV160	12,8	80	–	345	145	201	100	35	160	160,3	153	186	15	100	290	22	27	M20	3/4	
DKV160	12,8	80	–	345	145	201	100	35	160	160,3	153	186	15	100	290	22	27	M20	3/4	
DKV160	12,8	80	–	345	145	201	100	35	160	160,3	153	186	15	100	290	22	27	M20	3/4	
DKV160	12,8	80	–	345	145	201	100	35	160	160,3	153	186	15	100	290	22	27	M20	3/4	
DKV160	12,8	80	–	345	145	201	100	35	160	160,3	153	186	15	100	290	22	27	M20	3/4	
DKV160	22	80	–	380	155	229	110	40	190	170,3	163	178	15	112	320	26	32	M24	7/8	
DKV160	22	80	–	380	155	229	110	40	190	170,3	163	178	15	112	320	26	32	M24	7/8	
DKV160	22	80	–	380	155	229	110	40	190	170,3	163	178	15	112	320	26	32	M24	7/8	
DKV160	22	80	–	380	155	229	110	40	190	170,3	163	178	15	112	320	26	32	M24	7/8	
DKV160	22	80	–	380	155	229	110	40	190	170,3	163	178	15	112	320	26	32	M24	7/8	
DKV160	12,8	80,963	3 ³ / ₁₆	345	145	201	100	35	160	160,3	153	186	15	100	290	22	27	M20	3/4	
DKV160	12,8	80,963	3 ³ / ₁₆	345	145	201	100	35	160	160,3	153	186	15	100	290	22	27	M20	3/4	
DKV160	12,8	80,963	3 ³ / ₁₆	345	145	201	100	35	160	160,3	153	186	15	100	290	22	27	M20	3/4	
DKV160	12,8	80,963	3 ³ / ₁₆	345	145	201	100	35	160	160,3	153	186	15	100	290	22	27	M20	3/4	
DKV160	12,8	80,963	3 ³ / ₁₆	345	145	201	100	35	160	160,3	153	186	15	100	290	22	27	M20	3/4	
DKV160	22	80,963	3 ³ / ₁₆	380	155	229	110	40	190	170,3	163	178	15	112	320	26	32	M24	7/8	
DKV160	22	80,963	3 ³ / ₁₆	380	155	229	110	40	190	170,3	163	178	15	112	320	26	32	M24	7/8	
DKV160	22	80,963	3 ³ / ₁₆	380	155	229	110	40	190	170,3	163	178	15	112	320	26	32	M24	7/8	
DKV160	22	80,963	3 ³ / ₁₆	380	155	229	110	40	190	170,3	163	178	15	112	320	26	32	M24	7/8	
DKV160	22	80,963	3 ³ / ₁₆	380	155	229	110	40	190	170,3	163	178	15	112	320	26	32	M24	7/8	
DKV160	12,8	82,55	3 ¹ / ₄	345	145	201	100	35	160	160,3	153	186	15	100	290	22	27	M20	3/4	
DKV160	12,8	82,55	3 ¹ / ₄	345	145	201	100	35	160	160,3	153	186	15	100	290	22	27	M20	3/4	
DKV160	12,8	82,55	3 ¹ / ₄	345	145	201	100	35	160	160,3	153	186	15	100	290	22	27	M20	3/4	
DKV160	12,8	82,55	3 ¹ / ₄	345	145	201	100	35	160	160,3	153	186	15	100	290	22	27	M20	3/4	
DKV160	12,8	82,55	3 ¹ / ₄	345	145	201	100	35	160	160,3	153	186	15	100	290	22	27	M20	3/4	
DKV160	22	82,55	3 ¹ / ₄	380	155	229	110	40	190	170,3	163	178	15	112	320	26	32	M24	7/8	
DKV160	22	82,55	3 ¹ / ₄	380	155	229	110	40	190	170,3	163	178	15	112	320	26	32	M24	7/8	
DKV160	22	82,55	3 ¹ / ₄	380	155	229	110	40	190	170,3	163	178	15	112	320	26	32	M24	7/8	
DKV160	22	82,55	3 ¹ / ₄	380	155	229	110	40	190	170,3	163	178	15	112	320	26	32	M24	7/8	
DKV160	22	82,55	3 ¹ / ₄	380	155	229	110	40	190	170,3	163	178	15	112	320	26	32	M24	7/8	
DKV160	22	82,55	3 ¹ / ₄	380	155	229	110	40	190	170,3	163	178	15	112	320	26	32	M24	7/8	



Plummer block housings

SNV, split
For bearings with tapered bore and adapter sleeve

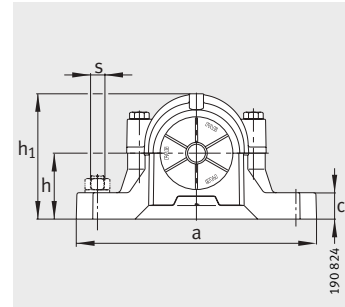
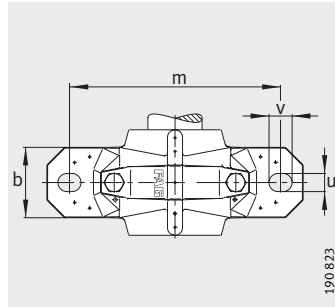

- ① Locating bearing
- ② Non-locating bearing

Dimension table (continued) - Dimensions in mm								
Designation								
Housing	Bearing	Adapter sleeve	Locating ring 2 pieces	Double lip seal	Labyrinth ring with round cord	Felt seal	V ring seal	Taconite seal
SNV170-L	1219-K-M-C3	H219	FRM170/18	DH519	TSV519	FSV519	DHV519	TCV519
SNV170-L	2219-K-M-C3	H319	FRM170/12,5	DH519	TSV519	FSV519	DHV519	TCV519
SNV170-L	22219-E1-K	H319	FRM170/12,5	DH519	TSV519	FSV519	DHV519	TCV519
SNV200-L	1319-K-M-C3	H319	FRM200/17,5	DH619	TSV619	FSV619	DHV619	TCV619
SNV200-L	21319-E1-K-TVPB	H319	FRM200/17,5	DH619	TSV619	FSV619	DHV619	TCV619
SNV200-L	2319-K-M-C3	H2319	FRM200/6,5	DH619	TSV619	FSV619	DHV619	TCV619
SNV200-L	22319-E1-K	H2319	FRM200/6,5	DH619	TSV619	FSV619	DHV619	TCV619
SNV170-L	1219-K-M-C3	H219X306	FRM170/18	DH519	TSV519X306	FSV519	DHV519	TCV519X306
SNV170-L	2219-K-M-C3	H319X306	FRM170/12,5	DH519	TSV519X306	FSV519	DHV519	TCV519X306
SNV170-L	22219-E1-K	H319X306	FRM170/12,5	DH519	TSV519X306	FSV519	DHV519	TCV519X306
SNV200-L	1319-K-M-C3	H319X306	FRM200/17,5	DH619	TSV619X306	FSV619	DHV619	TCV619X306
SNV200-L	21319-E1-K-TVPB	H319X306	FRM200/17,5	DH619	TSV619X306	FSV619	DHV619	TCV619X306
SNV200-L	2319-K-M-C3	H2319X306	FRM200/6,5	DH619	TSV619X306	FSV619	DHV619	TCV619X306
SNV200-L	22319-E1-K	H2319X306	FRM200/6,5	DH619	TSV619X306	FSV619	DHV619	TCV619X306
SNV180-L	1220-K-M-C3	H220X307	FRM180/18	DH520X307	TSV520X307	FSV520X307	DHV520X307	TCV520X307
SNV180-L	20220-K-MB-C3	H220X307	FRM180/18	DH520X307	TSV520X307	FSV520X307	DHV520X307	TCV520X307
SNV180-L	2220-K-M-C3	H320X307	FRM180/12	DH520X307	TSV520X307	FSV520X307	DHV520X307	TCV520X307
SNV180-L	22220-E1-K	H320X307	FRM180/12	DH520X307	TSV520X307	FSV520X307	DHV520X307	TCV520X307
SNV180-L	23220-E1-K-TVPB	H2320X307	FRM180/4,85	DH520X307	TSV520X307	FSV520X307	DHV520X307	TCV520X307
SNV215-L ¹⁾	1320-K-M-C3	H320X307	FRM215/19,5	DH620X307	TSV620X307	FSV620X307	DHV620X307	TCV620X307
SNV215-L ¹⁾	20320-K-MB-C3	H320X307	FRM215/19,5	DH620X307	TSV620X307	FSV620X307	DHV620X307	TCV620X307
SNV215-L ¹⁾	21320-E1-K-TVPB	H320X307	FRM215/19,5	DH620X307	TSV620X307	FSV620X307	DHV620X307	TCV620X307
SNV215-L ¹⁾	2320-K-M-C3	H2320X307	FRM215/6,5	DH620X307	TSV620X307	FSV620X307	DHV620X307	TCV620X307
SNV215-L ¹⁾	22320-E1-K	H2320X307	FRM215/6,5	DH620X307	TSV620X307	FSV620X307	DHV620X307	TCV620X307
SNV180-L	1220-K-M-C3	H220X308	FRM180/18	DH520X308	TSV520X308	FSV520X308	DHV520X308	TCV520X308
SNV180-L	20220-K-MB-C3	H220X308	FRM180/18	DH520X308	TSV520X308	FSV520X308	DHV520X308	TCV520X308
SNV180-L	2220-K-M-C3	H320X308	FRM180/12	DH520X308	TSV520X308	FSV520X308	DHV520X308	TCV520X308
SNV180-L	22220-E1-K	H320X308	FRM180/12	DH520X308	TSV520X308	FSV520X308	DHV520X308	TCV520X308
SNV180-L	23220-E1-K-TVPB	H2320X308	FRM180/4,85	DH520X308	TSV520X308	FSV520X308	DHV520X308	TCV520X308
SNV215-L ¹⁾	1320-K-M-C3	H320X308	FRM215/19,5	DH620	TSV620X308	FSV620X308	DHV620	TCV620X308
SNV215-L ¹⁾	20320-K-MB-C3	H320X308	FRM215/19,5	DH620	TSV620X308	FSV620X308	DHV620	TCV620X308
SNV215-L ¹⁾	21320-E1-K-TVPB	H320X308	FRM215/19,5	DH620	TSV620X308	FSV620X308	DHV620	TCV620X308
SNV215-L ¹⁾	2320-K-M-C3	H2320X308	FRM215/6,5	DH620	TSV620X308	FSV620X308	DHV620	TCV620X308
SNV215-L ¹⁾	22320-E1-K	H2320X308	FRM215/6,5	DH620	TSV620X308	FSV620X308	DHV620	TCV620X308

¹⁾ Housing with ring bolt.

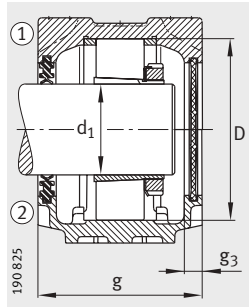

Double lip seal DH
Cover DKV

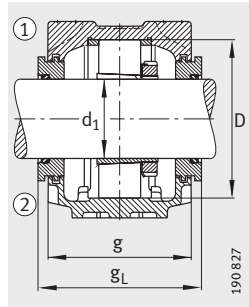

Labyrinth ring TSV

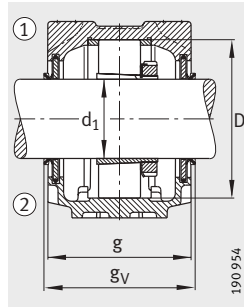

V ring seal DHV

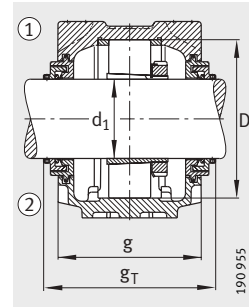

Taconite seal TCV

Cover	Mass m ≈kg	Dimensions																	
		Housing d ₁	a		g	h ₁	b	c	D	g _L	g _V	g _T	g ₃	h	m	u	v	s	
			mm	inch														mm	inch
DKV170	14,4	85	–	345	150	219	100	35	170	167,3	158	193	16	112	290	22	27	M20	3/4
DKV170	14,4	85	–	345	150	219	100	35	170	167,3	158	193	16	112	290	22	27	M20	3/4
DKV170	14,4	85	–	345	150	219	100	35	170	167,3	158	193	16	112	290	22	27	M20	3/4
DKV200	21	85	–	410	175	248	120	45	200	192,3	183	218	16	125	350	26	32	M24	7/8
DKV200	21	85	–	410	175	248	120	45	200	192,3	183	218	16	125	350	26	32	M24	7/8
DKV200	21	85	–	410	175	248	120	45	200	192,3	183	218	16	125	350	26	32	M24	7/8
DKV200	21	85	–	410	175	248	120	45	200	192,3	183	218	16	125	350	26	32	M24	7/8
DKV170	14,4	85,725	3 ³ / ₈	345	150	219	100	35	170	167,3	158	193	16	112	290	22	27	M20	3/4
DKV170	14,4	85,725	3 ³ / ₈	345	150	219	100	35	170	167,3	158	193	16	112	290	22	27	M20	3/4
DKV170	14,4	85,725	3 ³ / ₈	345	150	219	100	35	170	167,3	158	193	16	112	290	22	27	M20	3/4
DKV200	21	85,725	3 ³ / ₈	410	175	248	120	45	200	192,3	183	218	16	125	350	26	32	M24	7/8
DKV200	21	85,725	3 ³ / ₈	410	175	248	120	45	200	192,3	183	218	16	125	350	26	32	M24	7/8
DKV200	21	85,725	3 ³ / ₈	410	175	248	120	45	200	192,3	183	218	16	125	350	26	32	M24	7/8
DKV200	21	85,725	3 ³ / ₈	410	175	248	120	45	200	192,3	183	218	16	125	350	26	32	M24	7/8
DKV180	17	87,313	3 ⁷ / ₁₆	380	160	223	110	40	180	177,3	168	203	16	112	320	26	32	M24	7/8
DKV180	17	87,313	3 ⁷ / ₁₆	380	160	223	110	40	180	177,3	168	203	16	112	320	26	32	M24	7/8
DKV180	17	87,313	3 ⁷ / ₁₆	380	160	223	110	40	180	177,3	168	203	16	112	320	26	32	M24	7/8
DKV180	17	87,313	3 ⁷ / ₁₆	380	160	223	110	40	180	177,3	168	203	16	112	320	26	32	M24	7/8
DKV180	17	87,313	3 ⁷ / ₁₆	380	160	223	110	40	180	177,3	168	203	16	112	320	26	32	M24	7/8
DKV215	24,5	87,313	3 ⁷ / ₁₆	410	180	271	120	45	215	197,3	188	224	16	140	350	26	32	M24	7/8
DKV215	24,5	87,313	3 ⁷ / ₁₆	410	180	271	120	45	215	197,3	188	224	16	140	350	26	32	M24	7/8
DKV215	24,5	87,313	3 ⁷ / ₁₆	410	180	271	120	45	215	197,3	188	224	16	140	350	26	32	M24	7/8
DKV215	24,5	87,313	3 ⁷ / ₁₆	410	180	271	120	45	215	197,3	188	224	16	140	350	26	32	M24	7/8
DKV215	24,5	87,313	3 ⁷ / ₁₆	410	180	271	120	45	215	197,3	188	224	16	140	350	26	32	M24	7/8
DKV180	17	88,9	3 ¹ / ₂	380	160	223	110	40	180	177,3	168	203	16	112	320	26	32	M24	7/8
DKV180	17	88,9	3 ¹ / ₂	380	160	223	110	40	180	177,3	168	203	16	112	320	26	32	M24	7/8
DKV180	17	88,9	3 ¹ / ₂	380	160	223	110	40	180	177,3	168	203	16	112	320	26	32	M24	7/8
DKV180	17	88,9	3 ¹ / ₂	380	160	223	110	40	180	177,3	168	203	16	112	320	26	32	M24	7/8
DKV180	17	88,9	3 ¹ / ₂	380	160	223	110	40	180	177,3	168	203	16	112	320	26	32	M24	7/8
DKV215	24,5	88,9	3 ¹ / ₂	410	180	271	120	45	215	197,3	188	224	16	140	350	26	32	M24	7/8
DKV215	24,5	88,9	3 ¹ / ₂	410	180	271	120	45	215	197,3	188	224	16	140	350	26	32	M24	7/8
DKV215	24,5	88,9	3 ¹ / ₂	410	180	271	120	45	215	197,3	188	224	16	140	350	26	32	M24	7/8
DKV215	24,5	88,9	3 ¹ / ₂	410	180	271	120	45	215	197,3	188	224	16	140	350	26	32	M24	7/8
DKV215	24,5	88,9	3 ¹ / ₂	410	180	271	120	45	215	197,3	188	224	16	140	350	26	32	M24	7/8



Plummer block housings

SNV, split
For bearings with tapered bore and adapter sleeve

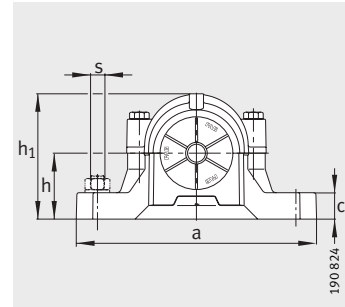
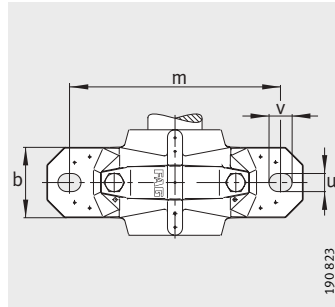

- ① Locating bearing
- ② Non-locating bearing

Dimension table (continued) · Dimensions in mm								
Designation								
Housing	Bearing	Adapter sleeve	Locating ring 2 pieces	Double lip seal	Labyrinth ring with round cord	Felt seal	V ring seal	Taconite seal
SNV180-L	1220-K-M-C3	H220	FRM180/18	DH520	TSV520	FSV520	DHV520	TCV520
SNV180-L	20220-K-MB-C3	H220	FRM180/18	DH520	TSV520	FSV520	DHV520	TCV520
SNV180-L	2220-K-M-C3	H320	FRM180/12	DH520	TSV520	FSV520	DHV520	TCV520
SNV180-L	22220-E1-K	H320	FRM180/12	DH520	TSV520	FSV520	DHV520	TCV520
SNV180-L	23220-E1-K-TVPB	H2320	FRM180/4,85	DH520	TSV520	FSV520	DHV520	TCV520
SNV215-L ¹⁾	1320-K-M-C3	H320	FRM215/19,5	DH620	TSV620	FSV620	DHV620	TCV620
SNV215-L ¹⁾	20320-K-MB-C3	H320	FRM215/19,5	DH620	TSV620	FSV620	DHV620	TCV620
SNV215-L ¹⁾	21320-E1-K-TVPB	H320	FRM215/19,5	DH620	TSV620	FSV620	DHV620	TCV620
SNV215-L ¹⁾	2320-K-M-C3	H2320	FRM215/6,5	DH620	TSV620	FSV620	DHV620	TCV620
SNV215-L ¹⁾	22320-E1-K	H2320	FRM215/6,5	DH620	TSV620	FSV620	DHV620	TCV620
SNV180-L	1220-K-M-C3	H220X310	FRM180/18	DH520X310	TSV520X310	FSV520X310	DHV520X310	TCV520X310
SNV180-L	20220-K-MB-C3	H220X310	FRM180/18	DH520X310	TSV520X310	FSV520X310	DHV520X310	TCV520X310
SNV180-L	2220-K-M-C3	H320X310	FRM180/12	DH520X310	TSV520X310	FSV520X310	DHV520X310	TCV520X310
SNV180-L	22220-E1-K	H320X310	FRM180/12	DH520X310	TSV520X310	FSV520X310	DHV520X310	TCV520X310
SNV180-L	23220-E1-K-TVPB	H2320X310	FRM180/4,85	DH520X310	TSV520X310	FSV520X310	DHV520X310	TCV520X310
SNV215-L ¹⁾	1320-K-M-C3	H320X310	FRM215/19,5	DH620X310	TSV620X310	FSV620X310	DHV620X310	TCV620X310
SNV215-L ¹⁾	20320-K-MB-C3	H320X310	FRM215/19,5	DH620X310	TSV620X310	FSV620X310	DHV620X310	TCV620X310
SNV215-L ¹⁾	21320-E1-K-TVPB	H320X310	FRM215/19,5	DH620X310	TSV620X310	FSV620X310	DHV620X310	TCV620X310
SNV215-L ¹⁾	2320-K-M-C3	H2320X310	FRM215/6,5	DH620X310	TSV620X310	FSV620X310	DHV620X310	TCV620X310
SNV215-L ¹⁾	22320-E1-K	H2320X310	FRM215/6,5	DH620X310	TSV620X310	FSV620X310	DHV620X310	TCV620X310
SNV180-L	1220-K-M-C3	H220X311	FRM180/18	DH520X310	TSV520X311	FSV520X311	DHV520X311	TCV520X311
SNV180-L	20220-K-MB-C3	H220X311	FRM180/18	DH520X310	TSV520X311	FSV520X311	DHV520X311	TCV520X311
SNV180-L	2220-K-M-C3	H320X311	FRM180/12	DH520X310	TSV520X311	FSV520X311	DHV520X311	TCV520X311
SNV180-L	22220-E1-K	H320X311	FRM180/12	DH520X310	TSV520X311	FSV520X311	DHV520X311	TCV520X311
SNV180-L	23220-E1-K-TVPB	H2320X311	FRM180/4,85	DH520X310	TSV520X311	FSV520X311	DHV520X311	TCV520X311
SNV215-L ¹⁾	1320-K-M-C3	H320X311	FRM215/19,5	DH620X310	TSV620X311	FSV620X311	DHV620X311	TCV620X311
SNV215-L ¹⁾	20320-K-MB-C3	H320X311	FRM215/19,5	DH620X310	TSV620X311	FSV620X311	DHV620X311	TCV620X311
SNV215-L ¹⁾	21320-E1-K-TVPB	H320X311	FRM215/19,5	DH620X310	TSV620X311	FSV620X311	DHV620X311	TCV620X311
SNV215-L ¹⁾	2320-K-M-C3	H2320X311	FRM215/6,5	DH620X310	TSV620X311	FSV620X311	DHV620X311	TCV620X311
SNV215-L ¹⁾	22320-E1-K	H2320X311	FRM215/6,5	DH620X310	TSV620X311	FSV620X311	DHV620X311	TCV620X311

¹⁾ Housing with ring bolt.

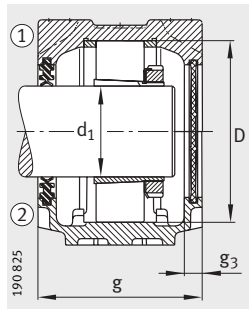

Double lip seal DH
Cover DKV

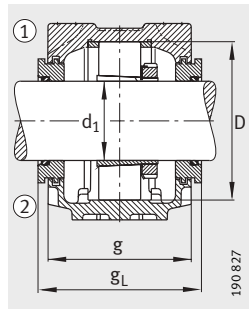

Labyrinth ring TSV

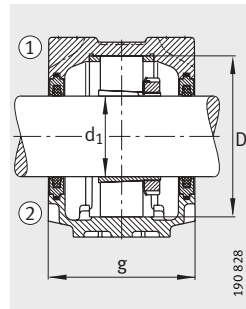

Felt seal FSV

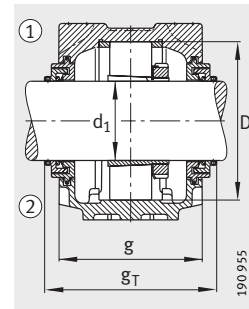

Taconite seal TCV

Cover	Mass m ≈kg	Dimensions																	
		Housing d ₁	a	g	h ₁	b	c	D	g _L	g _v	g _T	g ₃	h	m	u	v	s		
																	mm	inch	mm
DKV180	17	90	–	380	160	223	110	40	180	177,3	168	203	16	112	320	26	32	M24	7/8
DKV180	17	90	–	380	160	223	110	40	180	177,3	168	203	16	112	320	26	32	M24	7/8
DKV180	17	90	–	380	160	223	110	40	180	177,3	168	203	16	112	320	26	32	M24	7/8
DKV180	17	90	–	380	160	223	110	40	180	177,3	168	203	16	112	320	26	32	M24	7/8
DKV180	17	90	–	380	160	223	110	40	180	177,3	168	203	16	112	320	26	32	M24	7/8
DKV215	24,5	90	–	410	180	271	120	45	215	197,3	188	224	16	140	350	26	32	M24	7/8
DKV215	24,5	90	–	410	180	271	120	45	215	197,3	188	224	16	140	350	26	32	M24	7/8
DKV215	24,5	90	–	410	180	271	120	45	215	197,3	188	224	16	140	350	26	32	M24	7/8
DKV215	24,5	90	–	410	180	271	120	45	215	197,3	188	224	16	140	350	26	32	M24	7/8
DKV215	24,5	90	–	410	180	271	120	45	215	197,3	188	224	16	140	350	26	32	M24	7/8
DKV180	17	92,075	3 ⁵ / ₈	380	160	223	110	40	180	177,3	168	203	16	112	320	26	32	M24	7/8
DKV180	17	92,075	3 ⁵ / ₈	380	160	223	110	40	180	177,3	168	203	16	112	320	26	32	M24	7/8
DKV180	17	92,075	3 ⁵ / ₈	380	160	223	110	40	180	177,3	168	203	16	112	320	26	32	M24	7/8
DKV180	17	92,075	3 ⁵ / ₈	380	160	223	110	40	180	177,3	168	203	16	112	320	26	32	M24	7/8
DKV180	17	92,075	3 ⁵ / ₈	380	160	223	110	40	180	177,3	168	203	16	112	320	26	32	M24	7/8
DKV215	24,5	92,075	3 ⁵ / ₈	410	180	271	120	45	215	197,3	188	224	16	140	350	26	32	M24	7/8
DKV215	24,5	92,075	3 ⁵ / ₈	410	180	271	120	45	215	197,3	188	224	16	140	350	26	32	M24	7/8
DKV215	24,5	92,075	3 ⁵ / ₈	410	180	271	120	45	215	197,3	188	224	16	140	350	26	32	M24	7/8
DKV215	24,5	92,075	3 ⁵ / ₈	410	180	271	120	45	215	197,3	188	224	16	140	350	26	32	M24	7/8
DKV215	24,5	92,075	3 ⁵ / ₈	410	180	271	120	45	215	197,3	188	224	16	140	350	26	32	M24	7/8
DKV180	17	93,663	3 ¹¹ / ₁₆	380	160	223	110	40	180	177,3	168	203	16	112	320	26	32	M24	7/8
DKV180	17	93,663	3 ¹¹ / ₁₆	380	160	223	110	40	180	177,3	168	203	16	112	320	26	32	M24	7/8
DKV180	17	93,663	3 ¹¹ / ₁₆	380	160	223	110	40	180	177,3	168	203	16	112	320	26	32	M24	7/8
DKV180	17	93,663	3 ¹¹ / ₁₆	380	160	223	110	40	180	177,3	168	203	16	112	320	26	32	M24	7/8
DKV180	17	93,663	3 ¹¹ / ₁₆	380	160	223	110	40	180	177,3	168	203	16	112	320	26	32	M24	7/8
DKV215	24,5	93,663	3 ¹¹ / ₁₆	410	180	271	120	45	215	197,3	188	224	16	140	350	26	32	M24	7/8
DKV215	24,5	93,663	3 ¹¹ / ₁₆	410	180	271	120	45	215	197,3	188	224	16	140	350	26	32	M24	7/8
DKV215	24,5	93,663	3 ¹¹ / ₁₆	410	180	271	120	45	215	197,3	188	224	16	140	350	26	32	M24	7/8
DKV215	24,5	93,663	3 ¹¹ / ₁₆	410	180	271	120	45	215	197,3	188	224	16	140	350	26	32	M24	7/8
DKV215	24,5	93,663	3 ¹¹ / ₁₆	410	180	271	120	45	215	197,3	188	224	16	140	350	26	32	M24	7/8
DKV215	24,5	93,663	3 ¹¹ / ₁₆	410	180	271	120	45	215	197,3	188	224	16	140	350	26	32	M24	7/8



Plummer block housings

SNV, split
For bearings with tapered bore and adapter sleeve

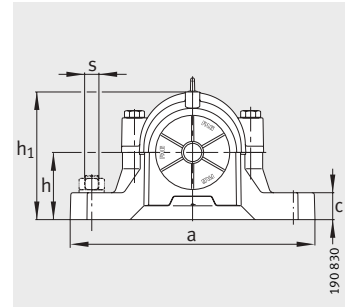
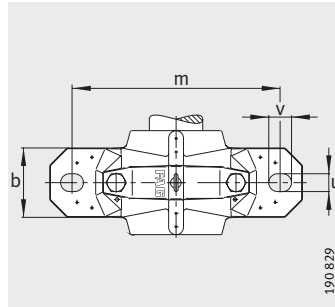

- ① Locating bearing
- ② Non-locating bearing

Dimension table (continued) · Dimensions in mm								
Designation								
Housing	Bearing	Adapter sleeve	Locating ring 2 pieces	Double lip seal	Labyrinth ring with round cord	Felt seal	V ring seal	Taconite seal
SNV200-L ¹⁾	1222-K-M-C3	H222X312	FRM200/21	DH522X312	TSV522X312	FSV522X312	DHV522X312	TCV522X312
SNV200-L ¹⁾	20222-K-MB-C3	H222X312	FRM200/21	DH522X312	TSV522X312	FSV522X312	DHV522X312	TCV522X312
SNV200-L ¹⁾	22222-E1-K	H322X312	FRM200/13,5	DH522X312	TSV522X312	FSV522X312	DHV522X312	TCV522X312
SNV200-L ¹⁾	23222-E1-K-TVPB	H2322X312	FRM200/5,1	DH522X312	TSV522X312	FSV522X312	DHV522X312	TCV522X312
SNV240-L	1322-K-M-C3	H322X312	FRM240/20	DH522X312	TSV522X312	FSV522X312	DHV522X312	TCV522X312
SNV240-L	21322-E1-K-TVPB	H322X312	FRM240/20	DH522X312	TSV522X312	FSV522X312	DHV522X312	TCV522X312
SNV240-L	2322-K-M-C3	H2322X312	FRM240/5	DH522X312	TSV522X312	FSV522X312	DHV522X312	TCV522X312
SNV240-L	22322-E1-K	H2322X312	FRM240/5	DH522X312	TSV522X312	FSV522X312	DHV522X312	TCV522X312
SNV200-L ¹⁾	1222-K-M-C3	H222X314	FRM200/21	DH522X314	TSV522X314	FSV522X314	DHV522X314	TCV522X314
SNV200-L ¹⁾	20222-K-MB-C3	H222X314	FRM200/21	DH522X314	TSV522X314	FSV522X314	DHV522X314	TCV522X314
SNV200-L ¹⁾	2222-K-M-C3	H322X314	FRM200/13,5	DH522X314	TSV522X314	FSV522X314	DHV522X314	TCV522X314
SNV200-L ¹⁾	22222-E1-K	H322X314	FRM200/13,5	DH522X314	TSV522X314	FSV522X314	DHV522X314	TCV522X314
SNV200-L ¹⁾	23222-E1-K-TVPB	H2322X314	FRM200/5,1	DH522X314	TSV522X314	FSV522X314	DHV522X314	TCV522X314
SNV240-L	1322-K-M-C3	H322X314	FRM240/20	DH522X314	TSV522X314	FSV522X314	DHV522X314	TCV522X314
SNV240-L	21322-E1-K-TVPB	H322X314	FRM240/20	DH522X314	TSV522X314	FSV522X314	DHV522X314	TCV522X314
SNV240-L	2322-K-M-C3	H2322X314	FRM240/5	DH522X314	TSV522X314	FSV522X314	DHV522X314	TCV522X314
SNV240-L	22322-E1-K	H2322X314	FRM240/5	DH522X314	TSV522X314	FSV522X314	DHV522X314	TCV522X314
SNV200-L ¹⁾	1222-K-M-C3	H222	FRM200/21	DH522	TSV522	FSV522	DHV522	TCV522
SNV200-L ¹⁾	20222-K-MB-C3	H222	FRM200/21	DH522	TSV522	FSV522	DHV522	TCV522
SNV200-L ¹⁾	2222-K-M-C3	H322	FRM200/13,5	DH522	TSV522	FSV522	DHV522	TCV522
SNV200-L ¹⁾	22222-E1-K	H322	FRM200/13,5	DH522	TSV522	FSV522	DHV522	TCV522
SNV200-L ¹⁾	23222-E1-K-TVPB	H2322	FRM200/5,1	DH522	TSV522	FSV522	DHV522	TCV522
SNV240-L	1322-K-M-C3	H322	FRM240/20	DH522	TSV522	FSV522	DHV522	TCV522
SNV240-L	21322-E1-K-TVPB	H322	FRM240/20	DH522	TSV522	FSV522	DHV522	TCV522
SNV240-L	2322-K-M-C3	H2322	FRM240/5	DH522	TSV522	FSV522	DHV522	TCV522
SNV240-L	22322-E1-K	H2322	FRM240/5	DH522	TSV522	FSV522	DHV522	TCV522
SNV200-L ¹⁾	1222-K-M-C3	H222X315	FRM200/21	DH522	TSV522	FSV522	DHV522	TCV522
SNV200-L ¹⁾	20222-K-MB-C3	H222X315	FRM200/21	DH522	TSV522	FSV522	DHV522	TCV522
SNV200-L ¹⁾	2222-K-M-C3	H322X315	FRM200/13,5	DH522	TSV522	FSV522	DHV522	TCV522
SNV200-L ¹⁾	22222-E1-K	H322X315	FRM200/13,5	DH522	TSV522	FSV522	DHV522	TCV522
SNV200-L ¹⁾	23222-E1-K-TVPB	H2322X315	FRM200/5,1	DH522	TSV522	FSV522	DHV522	TCV522
SNV240-L	1322-K-M-C3	H322X315	FRM240/20	DH522	TSV522	FSV522	DHV522	TCV522
SNV240-L	21322-E1-K-TVPB	H322X315	FRM240/20	DH522	TSV522	FSV522	DHV522	TCV522
SNV240-L	2322-K-M-C3	H2322X315	FRM240/5	DH522	TSV522	FSV522	DHV522	TCV522
SNV240-L	22322-E1-K	H2322X315	FRM240/5	DH522	TSV522	FSV522	DHV522	TCV522

¹⁾ Housing without ring bolt.

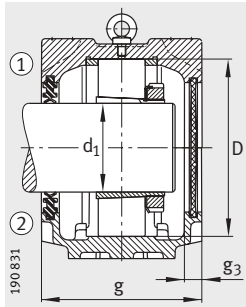

Double lip seal DH
Cover DKV

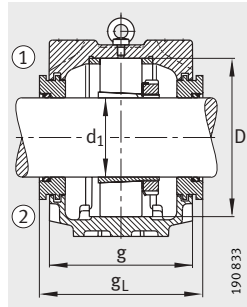

Labyrinth ring TSV

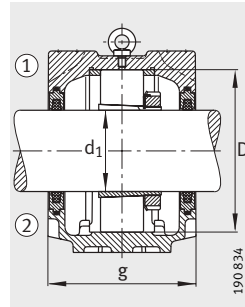

Felt seal FSV

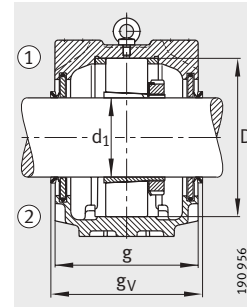

V ring seal DHV

Cover	Housing	Mass m ≈kg	Dimensions																	
			d ₁		a	g	h ₁	b	c	D	g _L	g _V	g _T	g ₃	h	m	u	v	s	
			mm	inch															mm	inch
DKV200	21	95,25	3 ³ / ₄	410	175	248	120	45	200	195,3	183	218	16	125	350	26	32	M24	7/8	
DKV200	21	95,25	3 ³ / ₄	410	175	248	120	45	200	195,3	183	218	16	125	350	26	32	M24	7/8	
DKV200	21	95,25	3 ³ / ₄	410	175	248	120	45	200	195,3	183	218	16	125	350	26	32	M24	7/8	
DKV200	21	95,25	3 ³ / ₄	410	175	248	120	45	200	195,3	183	218	16	125	350	26	32	M24	7/8	
DKV200	32	95,25	3 ³ / ₄	450	185	298	130	50	240	203,3	191	226	18	150	390	28	35	M24	1	
DKV200	32	95,25	3 ³ / ₄	450	185	298	130	50	240	203,3	191	226	18	150	390	28	35	M24	1	
DKV200	32	95,25	3 ³ / ₄	450	185	298	130	50	240	203,3	191	226	18	150	390	28	35	M24	1	
DKV200	32	95,25	3 ³ / ₄	450	185	298	130	50	240	203,3	191	226	18	150	390	28	35	M24	1	
DKV200	21	98,425	3 ⁷ / ₈	410	175	248	120	45	200	195,3	183	218	16	125	350	26	32	M24	7/8	
DKV200	21	98,425	3 ⁷ / ₈	410	175	248	120	45	200	195,3	183	218	16	125	350	26	32	M24	7/8	
DKV200	21	98,425	3 ⁷ / ₈	410	175	248	120	45	200	195,3	183	218	16	125	350	26	32	M24	7/8	
DKV200	21	98,425	3 ⁷ / ₈	410	175	248	120	45	200	195,3	183	218	16	125	350	26	32	M24	7/8	
DKV200	21	98,425	3 ⁷ / ₈	410	175	248	120	45	200	195,3	183	218	16	125	350	26	32	M24	7/8	
DKV200	32	98,425	3 ⁷ / ₈	450	185	298	130	50	240	203,3	191	226	18	150	390	28	35	M24	1	
DKV200	32	98,425	3 ⁷ / ₈	450	185	298	130	50	240	203,3	191	226	18	150	390	28	35	M24	1	
DKV200	32	98,425	3 ⁷ / ₈	450	185	298	130	50	240	203,3	191	226	18	150	390	28	35	M24	1	
DKV200	32	98,425	3 ⁷ / ₈	450	185	298	130	50	240	203,3	191	226	18	150	390	28	35	M24	1	
DKV200	21	100	–	410	175	248	120	45	200	195,3	183	218	16	125	350	26	32	M24	7/8	
DKV200	21	100	–	410	175	248	120	45	200	195,3	183	218	16	125	350	26	32	M24	7/8	
DKV200	21	100	–	410	175	248	120	45	200	195,3	183	218	16	125	350	26	32	M24	7/8	
DKV200	21	100	–	410	175	248	120	45	200	195,3	183	218	16	125	350	26	32	M24	7/8	
DKV200	21	100	–	410	175	248	120	45	200	195,3	183	218	16	125	350	26	32	M24	7/8	
DKV200	32	100	–	450	185	298	130	50	240	203,3	191	226	18	150	390	28	35	M24	1	
DKV200	32	100	–	450	185	298	130	50	240	203,3	191	226	18	150	390	28	35	M24	1	
DKV200	32	100	–	450	185	298	130	50	240	203,3	191	226	18	150	390	28	35	M24	1	
DKV200	32	100	–	450	185	298	130	50	240	203,3	191	226	18	150	390	28	35	M24	1	
DKV200	21	100,013	3 ¹⁵ / ₁₆	410	175	248	120	45	200	195,3	183	218	16	125	350	26	32	M24	7/8	
DKV200	21	100,013	3 ¹⁵ / ₁₆	410	175	248	120	45	200	195,3	183	218	16	125	350	26	32	M24	7/8	
DKV200	21	100,013	3 ¹⁵ / ₁₆	410	175	248	120	45	200	195,3	183	218	16	125	350	26	32	M24	7/8	
DKV200	21	100,013	3 ¹⁵ / ₁₆	410	175	248	120	45	200	195,3	183	218	16	125	350	26	32	M24	7/8	
DKV200	21	100,013	3 ¹⁵ / ₁₆	410	175	248	120	45	200	195,3	183	218	16	125	350	26	32	M24	7/8	
DKV200	32	100,013	3 ¹⁵ / ₁₆	450	185	298	130	50	240	203,3	191	226	18	150	390	28	35	M24	1	
DKV200	32	100,013	3 ¹⁵ / ₁₆	450	185	298	130	50	240	203,3	191	226	18	150	390	28	35	M24	1	
DKV200	32	100,013	3 ¹⁵ / ₁₆	450	185	298	130	50	240	203,3	191	226	18	150	390	28	35	M24	1	
DKV200	32	100,013	3 ¹⁵ / ₁₆	450	185	298	130	50	240	203,3	191	226	18	150	390	28	35	M24	1	



Plummer block housings

SNV, split
For bearings with tapered bore and adapter sleeve

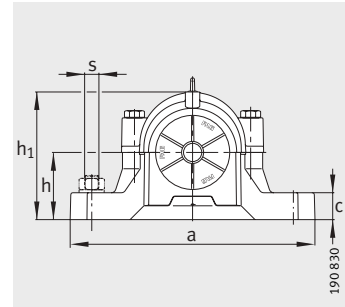
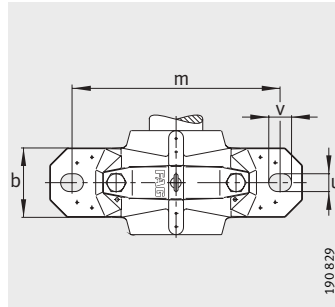

- ① Locating bearing
- ② Non-locating bearing

Dimension table (continued) - Dimensions in mm

Designation								
Housing	Bearing	Adapter sleeve	Locating ring 2 pieces	Double lip seal	Labyrinth ring with round cord	Felt seal	V ring seal	Taconite seal
SNV200-L ¹⁾	1222-K-M-C3	H222X400	FRM200/21	DH522	TSV522X400	FSV522X400	DHV522X400	TCV522X400
SNV200-L ¹⁾	20222-K-MB-C3	H222X400	FRM200/21	DH522	TSV522X400	FSV522X400	DHV522X400	TCV522X400
SNV200-L ¹⁾	2222-K-M-C3	H322X400	FRM200/13,5	DH522	TSV522X400	FSV522X400	DHV522X400	TCV522X400
SNV200-L ¹⁾	22222-E1-K	H322X400	FRM200/13,5	DH522	TSV522X400	FSV522X400	DHV522X400	TCV522X400
SNV200-L ¹⁾	23222-E1-K-TVPB	H2322X400	FRM200/5,1	DH522	TSV522X400	FSV522X400	DHV522X400	TCV522X400
SNV240-L	1322-K-M-C3	H322X400	FRM240/20	DH522	TSV522X400	FSV522X400	DHV522X400	TCV522X400
SNV240-L	21322-E1-K-TVPB	H322X400	FRM240/20	DH522	TSV522X400	FSV522X400	DHV522X400	TCV522X400
SNV240-L	2322-K-M-C3	H2322X400	FRM240/5	DH522	TSV522X400	FSV522X400	DHV522X400	TCV522X400
SNV240-L	22322-E1-K	H2322X400	FRM240/5	DH522	TSV522X400	FSV522X400	DHV522X400	TCV522X400
SNV215-L	20224-K-MB-C3	H3024X403	FRM215/23	DH524X403	TSV524X403	FSV524X403	DHV524X403	TCV524X403
SNV215-L	22224-E1-K	H3124X403	FRM215/14	DH524X403	TSV524X403	FSV524X403	DHV524X403	TCV524X403
SNV215-L	23224-E1-K-TVPB	H2324X403	FRM215/5	DH524X403	TSV524X403	FSV524X403	DHV524X403	TCV524X403
SNV260-L	22324-E1-K	H2324X403	FRM260/5	DH524X403	TSV524X403	FSV524X403	DHV524X403	TCV524X403
SNV215-L	20224-K-MB-C3	H3024X404	FRM215/23	DH524X404	TSV524X404	FSV524X404	DHV524X404	TCV524X404
SNV215-L	22224-E1-K	H3124X404	FRM215/14	DH524X404	TSV524X404	FSV524X404	DHV524X404	TCV524X404
SNV215-L	23224-E1-K-TVPB	H2324X404	FRM215/5	DH524X404	TSV524X404	FSV524X404	DHV524X404	TCV524X404
SNV260-L	22324-E1-K	H2324X404	FRM260/5	DH524X404	TSV524X404	FSV524X404	DHV524X404	TCV524X404
SNV215-L	20224-K-MB-C3	H3024	FRM215/23	DH524	TSV524	FSV524	DHV524	TCV524
SNV215-L	22224-E1-K	H3124	FRM215/14	DH524	TSV524	FSV524	DHV524	TCV524
SNV215-L	23224-E1-K-TVPB	H2324	FRM215/5	DH524	TSV524	FSV524	DHV524	TCV524
SNV260-L	22324-E1-K	H2324	FRM260/5	DH524	TSV524	FSV524	DHV524	TCV524
SNV230-L	20226-K-MB-C3	H3026X407	FRM230/25	DH526X407	TSV526X407	FSV526X407	DHV526X407	TCV526X407
SNV230-L	22226-E1-K	H3126X407	FRM230/13	DH526X407	TSV526X407	FSV526X407	DHV526X407	TCV526X407
SNV230-L	23226-E1-K-TVPB	H2326X407	FRM230/5	DH526X407	TSV526X407	FSV526X407	DHV526X407	TCV526X407
SNV280-L	22326-E1-K	H2326X407	FRM280/5	DH526X407	TSV526X407	FSV526X407	DHV526X407	TCV526X407
SNV230-L	20226-K-MB-C3	H3026X408	FRM230/25	DH526	TSV526X408	FSV526	DHV526	TCV526
SNV230-L	22226-E1-K	H3126X408	FRM230/13	DH526	TSV526X408	FSV526	DHV526	TCV526
SNV230-L	23226-E1-K-TVPB	H2326X408	FRM230/5	DH526	TSV526X408	FSV526	DHV526	TCV526
SNV280-L	22326-E1-K	H2326X408	FRM280/5	DH526	TSV526X408	FSV526	DHV526	TCV526

¹⁾ Housing without ring bolt.

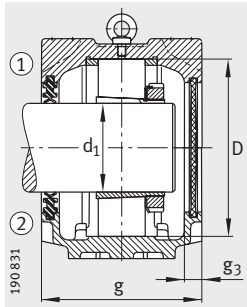

Double lip seal DH
Cover DKV

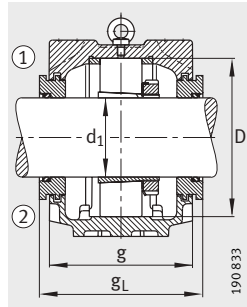

Labyrinth ring TSV

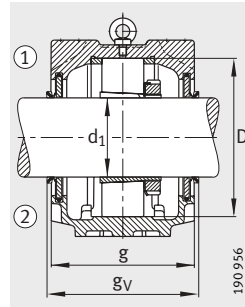

V ring seal DHV

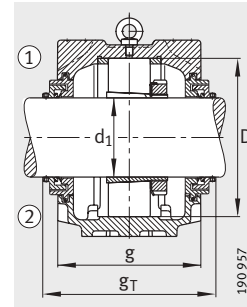

Taconite seal TCV

Cover	Mass m ≈kg	Dimensions																	
		Housing		d ₁	a	g	h ₁	b	c	D	g _L	g _V	g _T	g ₃	h	m	u	v	s
		mm	inch																
DKV200	21	101,6	4	410	175	248	120	45	200	195,3	183	218	16	125	350	26	32	M24	7/8
DKV200	21	101,6	4	410	175	248	120	45	200	195,3	183	218	16	125	350	26	32	M24	7/8
DKV200	21	101,6	4	410	175	248	120	45	200	195,3	183	218	16	125	350	26	32	M24	7/8
DKV200	21	101,6	4	410	175	248	120	45	200	195,3	183	218	16	125	350	26	32	M24	7/8
DKV200	21	101,6	4	410	175	248	120	45	200	195,3	183	218	16	125	350	26	32	M24	7/8
DKV200	32	101,6	4	450	185	298	130	50	240	203,3	191	226	18	150	390	28	35	M24	1
DKV200	32	101,6	4	450	185	298	130	50	240	203,3	191	226	18	150	390	28	35	M24	1
DKV200	32	101,6	4	450	185	298	130	50	240	203,3	191	226	18	150	390	28	35	M24	1
DKV200	32	101,6	4	450	185	298	130	50	240	203,3	191	226	18	150	390	28	35	M24	1
DKV215	24,5	106,363	4 ^{3/16}	410	180	271	120	45	215	200,3	191	227	16	140	350	26	32	M24	7/8
DKV215	24,5	106,363	4 ^{3/16}	410	180	271	120	45	215	200,3	191	227	16	140	350	26	32	M24	7/8
DKV215	24,5	106,363	4 ^{3/16}	410	180	271	120	45	215	200,3	191	227	16	140	350	26	32	M24	7/8
DKV215	48	106,363	4 ^{3/16}	530	190	321	160	60	260	208,3	199	235	18	160	450	35	42	M30	1 ^{1/4}
DKV215	24,5	107,95	4 ^{1/4}	410	180	271	120	45	215	200,3	191	227	16	140	350	26	32	M24	7/8
DKV215	24,5	107,95	4 ^{1/4}	410	180	271	120	45	215	200,3	191	227	16	140	350	26	32	M24	7/8
DKV215	24,5	107,95	4 ^{1/4}	410	180	271	120	45	215	200,3	191	227	16	140	350	26	32	M24	7/8
DKV215	48	107,95	4 ^{1/4}	530	190	321	160	60	260	208,3	199	235	18	160	450	35	42	M30	1 ^{1/4}
DKV215	24,5	110	–	410	180	271	120	45	215	200,3	191	227	16	140	350	26	32	M24	7/8
DKV215	24,5	110	–	410	180	271	120	45	215	200,3	191	227	16	140	350	26	32	M24	7/8
DKV215	24,5	110	–	410	180	271	120	45	215	200,3	191	227	16	140	350	26	32	M24	7/8
DKV215	48	110	–	530	190	321	160	60	260	208,3	199	235	18	160	450	35	42	M30	1 ^{1/4}
DKV230	30	112,713	4 ^{7/16}	445	190	291	130	50	230	208,3	199	235	18	150	380	28	35	M24	1
DKV230	30	112,713	4 ^{7/16}	445	190	291	130	50	230	208,3	199	235	18	150	380	28	35	M24	1
DKV230	30	112,713	4 ^{7/16}	445	190	291	130	50	230	208,3	199	235	18	150	380	28	35	M24	1
DKV230	55	112,713	4 ^{7/16}	550	205	344	160	60	280	223,3	214	250	18	170	470	35	42	M30	1 ^{1/4}
DKV230	30	114,3	4 ^{1/2}	445	190	291	130	50	230	208,3	199	235	18	150	380	28	35	M24	1
DKV230	30	114,3	4 ^{1/2}	445	190	291	130	50	230	208,3	199	235	18	150	380	28	35	M24	1
DKV230	30	114,3	4 ^{1/2}	445	190	291	130	50	230	208,3	199	235	18	150	380	28	35	M24	1
DKV230	55	114,3	4 ^{1/2}	550	205	344	160	60	280	223,3	214	250	18	170	470	35	42	M30	1 ^{1/4}



Plummer block housings

SNV, split
For bearings with tapered bore and adapter sleeve

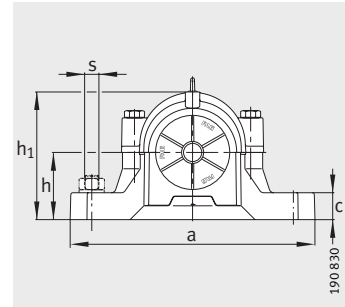
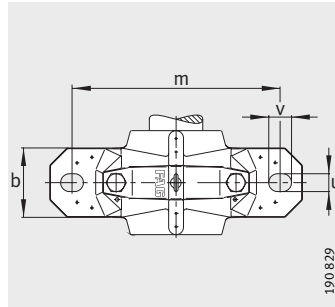

- ① Locating bearing
- ② Non-locating bearing

Dimension table (continued) · Dimensions in mm								
Designation								
Housing	Bearing	Adapter sleeve	Locating ring 2 pieces	Double lip seal	Labyrinth ring with round cord	Felt seal	V ring seal	Taconite seal
SNV230-L	20226-K-MB-C3	H3026	FRM230/25	DH526	TSV526	FSV526	DHV526	TCV526
SNV230-L	22226-E1-K	H3126	FRM230/13	DH526	TSV526	FSV526	DHV526	TCV526
SNV230-L	23226-E1-K-TVPB	H2326	FRM230/5	DH526	TSV526	FSV526	DHV526	TCV526
SNV280-L	22326-E1-K	H2326	FRM280/5	DH526	TSV526	FSV526	DHV526	TCV526
SNV230-L	20226-K-MB-C3	H3026X412	FRM230/25	DH526X412	TSV526X412	FSV526X412	DHV526X412	TCV526X412
SNV230-L	22226-E1-K	H3126X412	FRM230/13	DH526X412	TSV526X412	FSV526X412	DHV526X412	TCV526X412
SNV230-L	23226-E1-K-TVPB	H2326X412	FRM230/5	DH526X412	TSV526X412	FSV526X412	DHV526X412	TCV526X412
SNV280-L	22326-E1-K	H2326X412	FRM280/5	DH526X412	TSV526X412	FSV526X412	DHV526X412	TCV526X412
SNV250-L	20228-K-MB-C3	H3028	FRM250/28	DH528	TSV528	FSV528	DHV528	TCV528
SNV250-L	22228-E1-K	H3128	FRM250/15	DH528	TSV528	FSV528	DHV528	TCV528
SNV250-L	23228-E1-K-TVPB	H2328	FRM250/5	DH528	TSV528	FSV528	DHV528	TCV528
SNV300-L	22328-E1-K	H2328	FRM300/5	DH528	TSV528	FSV528	DHV528	TCV528
SNV250-L	20228-K-MB-C3	H3028X415	FRM250/28	DH528	TSV528X415	FSV528	DHV528	TCV528X415
SNV250-L	22228-E1-K	H3128X415	FRM250/15	DH528	TSV528X415	FSV528	DHV528	TCV528X415
SNV250-L	23228-E1-K-TVPB	H2328X415	FRM250/5	DH528	TSV528X415	FSV528	DHV528	TCV528X415
SNV300-L	22328-E1-K	H2328X415	FRM300/5	DH528	TSV528X415	FSV528	DHV528	TCV528X415
SNV250-L	20228-K-MB-C3	H3028X500	FRM250/28	DH528	TSV528X500	FSV528X500	DHV528X500	TCV528X500
SNV250-L	22228-E1-K	H3128X500	FRM250/15	DH528	TSV528X500	FSV528X500	DHV528X500	TCV528X500
SNV250-L	23228-E1-K-TVPB	H2328X500	FRM250/5	DH528	TSV528X500	FSV528X500	DHV528X500	TCV528X500
SNV300-L	22328-E1-K	H2328X500	FRM300/5	DH528	TSV528X500	FSV528X500	DHV528X500	TCV528X500
SNV270-L	20230-K-MB-C3	H3030X503	FRM270/30,5	DH530X503	TSV530X503	FSV530X503	DHV530X503	TCV530X503
SNV270-L	22230-E1-K	H3130X503	FRM270/16,5	DH530X503	TSV530X503	FSV530X503	DHV530X503	TCV530X503
SNV270-L	23230-E1-K-TVPB	H2330X503	FRM270/5	DH530X503	TSV530X503	FSV530X503	DHV530X503	TCV530X503
SNV320-L	22330-E1-K	H2330X503	FRM320/5	DH530X503	TSV530X503	FSV530X503	DHV530X503	TCV530X503
SNV270-L	20230-K-MB-C3	H3030X504	FRM270/30,5	DH530X504	TSV530X504	FSV530X504	DHV530X504	TCV530X504
SNV270-L	22230-E1-K	H3130X504	FRM270/16,5	DH530X504	TSV530X504	FSV530X504	DHV530X504	TCV530X504
SNV270-L	23230-E1-K-TVPB	H2330X504	FRM270/5	DH530X504	TSV530X504	FSV530X504	DHV530X504	TCV530X504
SNV320-L	22330-E1-K	H2330X504	FRM320/5	DH530X504	TSV530X504	FSV530X504	DHV530X504	TCV530X504

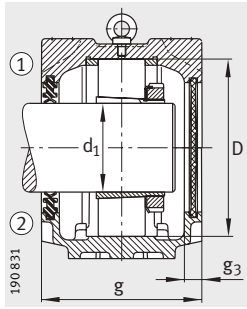

Double lip seal DH
Cover DKV

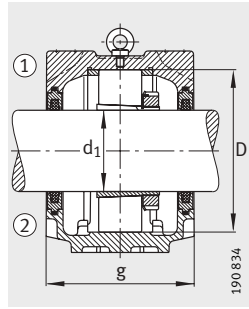

Felt seal FSV

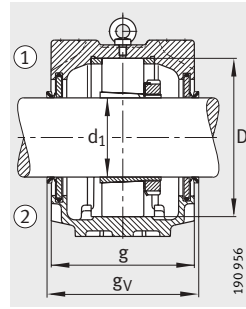

V ring seal DHV

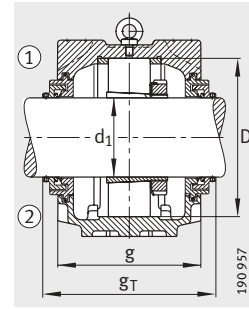

Taconite seal TCV

Cover	Mass m Housing ≈kg	Dimensions																	
		d ₁		a	g	h ₁	b	c	D	g _L	g _V	g _T	g ₃	h	m	u	v	s	
		mm	inch															mm	inch
DKV230	30	115	-	445	190	291	130	50	230	208,3	199	235	18	150	380	28	35	M24	1
DKV230	30	115	-	445	190	291	130	50	230	208,3	199	235	18	150	380	28	35	M24	1
DKV230	30	115	-	445	190	291	130	50	230	208,3	199	235	18	150	380	28	35	M24	1
DKV230	55	115	-	550	205	344	160	60	280	223,3	214	250	18	170	470	35	42	M30	1 ^{1/4}
DKV230	30	120,65	4 ^{3/4}	445	190	291	130	50	230	208,3	199	235	18	150	380	28	35	M24	1
DKV230	30	120,65	4 ^{3/4}	445	190	291	130	50	230	208,3	199	235	18	150	380	28	35	M24	1
DKV230	30	120,65	4 ^{3/4}	445	190	291	130	50	230	208,3	199	235	18	150	380	28	35	M24	1
DKV230	55	120,65	4 ^{3/4}	550	205	344	160	60	280	223,3	214	250	18	170	470	35	42	M30	1 ^{1/4}
DKV250	38	125	-	500	200	304	150	50	250	218,3	209	245	18	150	420	35	42	M30	1 ^{1/4}
DKV250	38	125	-	500	200	304	150	50	250	218,3	209	245	18	150	420	35	42	M30	1 ^{1/4}
DKV250	38	125	-	500	200	304	150	50	250	218,3	209	245	18	150	420	35	42	M30	1 ^{1/4}
DKV250	70	125	-	620	215	366	170	65	300	233,3	224	260	18	180	520	35	42	M30	1 ^{1/4}
DKV250	38	125,413	4 ^{15/16}	500	200	304	150	50	250	218,3	209	245	18	150	420	35	42	M30	1 ^{1/4}
DKV250	38	125,413	4 ^{15/16}	500	200	304	150	50	250	218,3	209	245	18	150	420	35	42	M30	1 ^{1/4}
DKV250	38	125,413	4 ^{15/16}	500	200	304	150	50	250	218,3	209	245	18	150	420	35	42	M30	1 ^{1/4}
DKV250	70	125,413	4 ^{15/16}	620	215	366	170	65	300	233,3	224	260	18	180	520	35	42	M30	1 ^{1/4}
DKV250	38	127	5	500	200	304	150	50	250	218,3	209	245	18	150	420	35	42	M30	1 ^{1/4}
DKV250	38	127	5	500	200	304	150	50	250	218,3	209	245	18	150	420	35	42	M30	1 ^{1/4}
DKV250	38	127	5	500	200	304	150	50	250	218,3	209	245	18	150	420	35	42	M30	1 ^{1/4}
DKV250	70	127	5	620	215	366	170	65	300	233,3	224	260	18	180	520	35	42	M30	1 ^{1/4}
DKV270	45,5	131,763	5 ^{3/16}	530	215	328	160	60	270	233,3	224	260	18	160	450	35	42	M30	1 ^{1/4}
DKV270	45,5	131,763	5 ^{3/16}	530	215	328	160	60	270	233,3	224	260	18	160	450	35	42	M30	1 ^{1/4}
DKV270	45,5	131,763	5 ^{3/16}	530	215	328	160	60	270	233,3	224	260	18	160	450	35	42	M30	1 ^{1/4}
DKV270	95	131,763	5 ^{3/16}	650	225	386	180	65	320	243,3	234	270	18	190	560	35	42	M30	1 ^{1/4}
DKV270	45,5	133,35	5 ^{1/4}	530	215	328	160	60	270	233,3	224	260	18	160	450	35	42	M30	1 ^{1/4}
DKV270	45,5	133,35	5 ^{1/4}	530	215	328	160	60	270	233,3	224	260	18	160	450	35	42	M30	1 ^{1/4}
DKV270	45,5	133,35	5 ^{1/4}	530	215	328	160	60	270	233,3	224	260	18	160	450	35	42	M30	1 ^{1/4}
DKV270	95	133,35	5 ^{1/4}	650	225	386	180	65	320	243,3	234	270	18	190	560	35	42	M30	1 ^{1/4}



Plummer block housings

SNV, split
For bearings with tapered bore and adapter sleeve

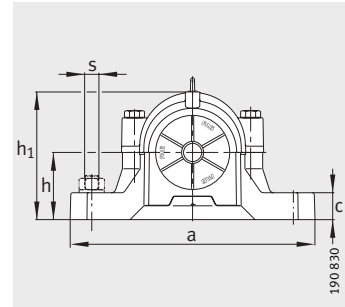
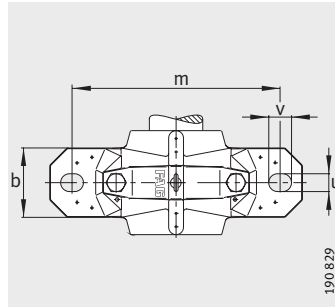

- ① Locating bearing
- ② Non-locating bearing

Dimension table (continued) · Dimensions in mm

Designation								
Housing	Bearing	Adapter sleeve	Locating ring 2 pieces	Double lip seal	Labyrinth ring with round cord	Felt seal	V ring seal	Taconite seal
SNV270-L	20230-K-MB-C3	H3030	FRM270/30,5	DH530	TSV530	FSV530	DHV530	TCV530
SNV270-L	22230-E1-K	H3130	FRM270/16,5	DH530	TSV530	FSV530	DHV530	TCV530
SNV270-L	23230-E1-K-TVPB	H2330	FRM270/5	DH530	TSV530	FSV530	DHV530	TCV530
SNV320-L	22330-E1-K	H2330	FRM320/5	DH530	TSV530	FSV530	DHV530	TCV530
SNV290-L	20232-K-MB-C3	H3032X507	FRM290/33	DH532X507	TSV532X507	FSV532X507	DHV532X507	TCV532X507
SNV290-L	22232-E1-K	H3132X507	FRM290/17	DH532X507	TSV532X507	FSV532X507	DHV532X507	TCV532X507
SNV290-L	23232-E1-K-TVPB	H2332X507	FRM290/5	DH532X507	TSV532X507	FSV532X507	DHV532X507	TCV532X507
SNV340-L	22332-K-MB	H2332X507	FRM340/5	DH532X507	TSV532X507	FSV532X507	DHV532X507	TCV532X507
SNV290-L	20232-K-MB-C3	H3032X508	FRM290/33	DH532	TSV532	FSV532	DHV532	TCV532
SNV290-L	22232-E1-K	H3132X508	FRM290/17	DH532	TSV532	FSV532	DHV532	TCV532
SNV290-L	23232-E1-K-TVPB	H2332X508	FRM290/5	DH532	TSV532	FSV532	DHV532	TCV532
SNV340-L	22332-K-MB	H2332X508	FRM340/5	DH532	TSV532	FSV532	DHV532	TCV532
SNV290-L	20232-K-MB-C3	H3032	FRM290/33	DH532	TSV532	FSV532	DHV532	TCV532
SNV290-L	22232-E1-K	H3132	FRM290/17	DH532	TSV532	FSV532	DHV532	TCV532
SNV290-L	23232-E1-K-TVPB	H2332	FRM290/5	DH532	TSV532	FSV532	DHV532	TCV532
SNV340-L	22332-K-MB	H2332	FRM340/5	DH532	TSV532	FSV532	DHV532	TCV532

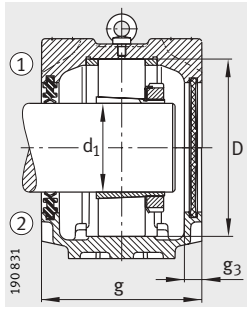

Double lip seal DH
Cover DKV

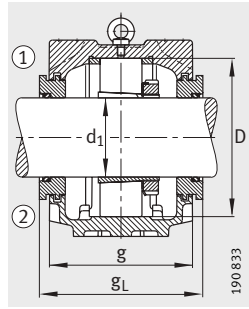

Labyrinth ring TSV

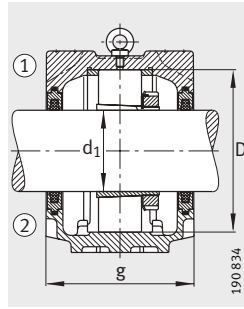

Felt seal FSV

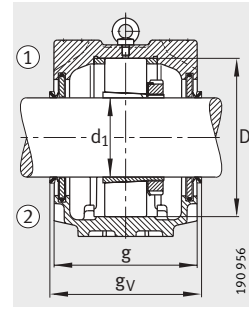

V ring seal DHV

Cover	Mass m Housing ≈kg	Dimensions																	
		d ₁		a	g	h ₁	b	c	D	g _L	g _V	g _T	g ₃	h	m	u	v	s	
		mm	inch															mm	inch
DKV270	45,5	135	–	530	215	328	160	60	270	233,3	224	260	18	160	450	35	42	M30	1 ¹ / ₄
DKV270	45,5	135	–	530	215	328	160	60	270	233,3	224	260	18	160	450	35	42	M30	1 ¹ / ₄
DKV270	45,5	135	–	530	215	328	160	60	270	233,3	224	260	18	160	450	35	42	M30	1 ¹ / ₄
DKV270	95	135	–	650	225	386	180	65	320	243,3	234	270	18	190	560	35	42	M30	1 ¹ / ₄
DKV290	53,8	138,113	5 ⁷ / ₁₆	550	225	351	160	60	290	243,3	234	270	18	170	470	35	42	M30	1 ¹ / ₄
DKV290	53,8	138,113	5 ⁷ / ₁₆	550	225	351	160	60	290	243,3	234	270	18	170	470	35	42	M30	1 ¹ / ₄
DKV290	53,8	138,113	5 ⁷ / ₁₆	550	225	351	160	60	290	243,3	234	270	18	170	470	35	42	M30	1 ¹ / ₄
DKV290	115	138,113	5 ⁷ / ₁₆	680	235	406	190	70	340	253,3	244	298	18	200	580	42	50	M36	1 ¹ / ₂
DKV290	53,8	139,7	5 ¹ / ₂	550	225	351	160	60	290	243,3	234	270	18	170	470	35	42	M30	1 ¹ / ₄
DKV290	53,8	139,7	5 ¹ / ₂	550	225	351	160	60	290	243,3	234	270	18	170	470	35	42	M30	1 ¹ / ₄
DKV290	53,8	139,7	5 ¹ / ₂	550	225	351	160	60	290	243,3	234	270	18	170	470	35	42	M30	1 ¹ / ₄
DKV290	115	139,7	5 ¹ / ₂	680	235	406	190	70	340	253,3	244	298	18	200	580	42	50	M36	1 ¹ / ₂
DKV290	53,8	140	–	550	225	351	160	60	290	243,3	234	270	18	170	470	35	42	M30	1 ¹ / ₄
DKV290	53,8	140	–	550	225	351	160	60	290	243,3	234	270	18	170	470	35	42	M30	1 ¹ / ₄
DKV290	53,8	140	–	550	225	351	160	60	290	243,3	234	270	18	170	470	35	42	M30	1 ¹ / ₄
DKV290	115	140	–	680	235	406	190	70	340	253,3	244	298	18	200	580	42	50	M36	1 ¹ / ₂



Plummer block housings

SNV, split
For bearings with cylindrical bore

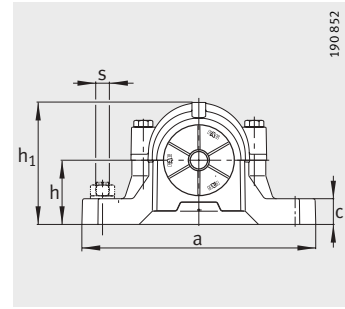
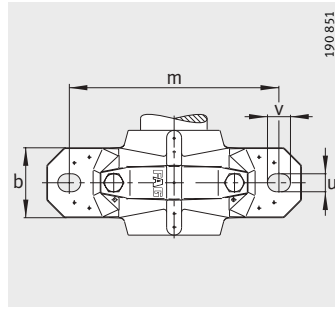

- ① Locating bearing
- ② Non-locating bearing

Dimension table · Dimensions in mm										Mass m Housing ≈kg
Designation										
Housing	Bearing	Lock-nut	Retain- ing plate	Locating ring 2 pieces	Double lip seal	Labyrinth ring with round cord	Felt seal	V ring seal	Cover	
SNV052-L	1304-TVH	KM4	MB4	FRM52/6	DH304	TSV304	–	DHV304	DKV052	1,3
SNV052-L	20304-TVP	KM4	MB4	FRM52/6	DH304	TSV304	–	DHV304	DKV052	1,3
SNV052-L	21304-E1-TVPB	KM4	MB4	FRM52/6	DH304	TSV304	–	DHV304	DKV052	1,3
SNV052-L	2304-TVH	KM4	MB4	FRM52/3	DH304	TSV304	–	DHV304	DKV052	1,3
SNV052-L	1205-TVH	KM5	MB5	FRM52/6	DH205	TSV205	–	–	DKV052	1,3
SNV052-L	20205-TVP	KM5	MB5	FRM52/6	DH205	TSV205	–	–	DKV052	1,3
SNV052-L	2205-TVH	KM5	MB5	FRM52/4,5	DH205	TSV205	–	–	DKV052	1,3
SNV052-L	22205-E1	KM5	MB5	FRM52/4,5	DH205	TSV205	–	–	DKV052	1,3
SNV062-L	1305-TVH	KM5	MB5	FRM62/6,5	DH305	TSV305	FSV305	DHV305	DKV062	1,9
SNV062-L	20305-TVP	KM5	MB5	FRM62/6,5	DH305	TSV305	FSV305	DHV305	DKV062	1,9
SNV062-L	21305-E1-TVPB	KM5	MB5	FRM62/6,5	DH305	TSV305	FSV305	DHV305	DKV062	1,9
SNV062-L	2305-TVH	KM5	MB5	FRM62/3	DH305	TSV305	FSV305	DHV305	DKV062	1,9
SNV062-L	1206-TVH	KM6	MB6	FRM62/7	DH206	TSV206	–	–	DKV062	1,9
SNV062-L	20206-TVP	KM6	MB6	FRM62/7	DH206	TSV206	–	–	DKV062	1,9
SNV062-L	2206-TVH	KM6	MB6	FRM62/5	DH206	TSV206	–	–	DKV062	1,9
SNV062-L	22206-E1	KM6	MB6	FRM62/5	DH206	TSV206	–	–	DKV062	1,9
SNV072-L	1306-TVH	KM6	MB6	FRM72/7	DH306	TSV306	FSV306	DHV306	DKV072	2
SNV072-L	20306-TVP	KM6	MB6	FRM72/7	DH306	TSV306	FSV306	DHV306	DKV072	2
SNV072-L	21306-E1-TVPB	KM6	MB6	FRM72/7	DH306	TSV306	FSV306	DHV306	DKV072	2
SNV072-L	2306-TVH	KM6	MB6	FRM72/3	DH306	TSV306	FSV306	DHV306	DKV072	2
SNV072-L	1207-TVH	KM7	MB7	FRM72/8	DH207	TSV207	–	–	DKV072	2
SNV072-L	20207-TVP	KM7	MB7	FRM72/8	DH207	TSV207	–	–	DKV072	2
SNV072-L	2207-TVH	KM7	MB7	FRM72/5	DH207	TSV207	–	–	DKV072	2
SNV072-L	22207-E1	KM7	MB7	FRM72/5	DH207	TSV207	–	–	DKV072	2
SNV080-L	1307-TVH	KM7	MB7	FRM80/9	DH307	TSV307	FSV307	DHV307	DKV080	2,9
SNV080-L	20307-TVP	KM7	MB7	FRM80/9	DH307	TSV307	FSV307	DHV307	DKV080	2,9
SNV080-L	21307-E1-TVPB	KM7	MB7	FRM80/9	DH307	TSV307	FSV307	DHV307	DKV080	2,9
SNV080-L	2307-TVH	KM7	MB7	FRM80/4	DH307	TSV307	FSV307	DHV307	DKV080	2,9

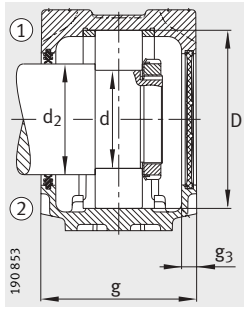

Double lip seal DH
Cover DKV

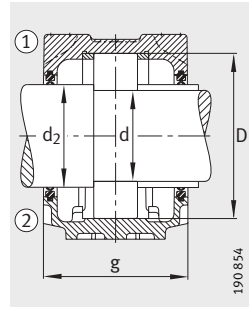

Double lip seal DH

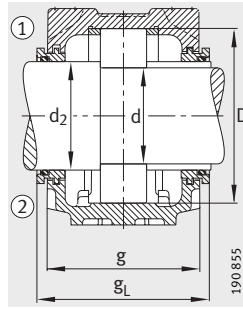

Labyrinth ring TSV

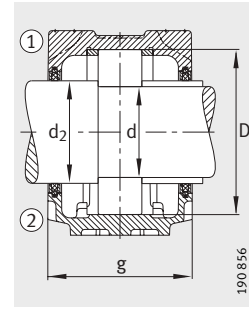

Felt seal FSV

Dimensions

d	a	g	h ₁	d ₂	b	c	D	g _L	g _V	g ₃	h	m	u	v	s	
															mm	inch
20	165	70	75	25	46	19	52	95	76	10,5	40	130	15	20	M12	1/2
20	165	70	75	25	46	19	52	95	76	10,5	40	130	15	20	M12	1/2
20	165	70	75	25	46	19	52	95	76	10,5	40	130	15	20	M12	1/2
20	165	70	75	25	46	19	52	95	76	10,5	40	130	15	20	M12	1/2
25	165	70	75	30	46	19	52	95	-	10,5	40	130	15	20	M12	1/2
25	165	70	75	30	46	19	52	95	-	10,5	40	130	15	20	M12	1/2
25	165	70	75	30	46	19	52	95	-	10,5	40	130	15	20	M12	1/2
25	165	70	75	30	46	19	52	95	-	10,5	40	130	15	20	M12	1/2
25	185	75	91	30	52	22	62	100	81	10,5	50	150	15	20	M12	1/2
25	185	75	91	30	52	22	62	100	81	10,5	50	150	15	20	M12	1/2
25	185	75	91	30	52	22	62	100	81	10,5	50	150	15	20	M12	1/2
25	185	75	91	30	52	22	62	100	81	10,5	50	150	15	20	M12	1/2
30	185	75	91	35	52	22	62	100	-	10,5	50	150	15	20	M12	1/2
30	185	75	91	35	52	22	62	100	-	10,5	50	150	15	20	M12	1/2
30	185	75	91	35	52	22	62	100	-	10,5	50	150	15	20	M12	1/2
30	185	75	91	35	52	22	62	100	-	10,5	50	150	15	20	M12	1/2
30	185	80	97	35	52	22	72	93	86	10,5	50	150	15	20	M12	1/2
30	185	80	97	35	52	22	72	93	86	10,5	50	150	15	20	M12	1/2
30	185	80	97	35	52	22	72	93	86	10,5	50	150	15	20	M12	1/2
30	185	80	97	35	52	22	72	93	86	10,5	50	150	15	20	M12	1/2
35	185	80	97	45	52	22	72	107	-	10,5	50	150	15	20	M12	1/2
35	185	80	97	45	52	22	72	107	-	10,5	50	150	15	20	M12	1/2
35	185	80	97	45	52	22	72	107	-	10,5	50	150	15	20	M12	1/2
35	185	80	97	45	52	22	72	107	-	10,5	50	150	15	20	M12	1/2
35	205	85	112	45	60	25	80	98	93	10,5	60	170	15	20	M12	1/2
35	205	85	112	45	60	25	80	98	93	10,5	60	170	15	20	M12	1/2
35	205	85	112	45	60	25	80	98	93	10,5	60	170	15	20	M12	1/2
35	205	85	112	45	60	25	80	98	93	10,5	60	170	15	20	M12	1/2



Plummer block housings

SNV, split
For bearings with cylindrical bore

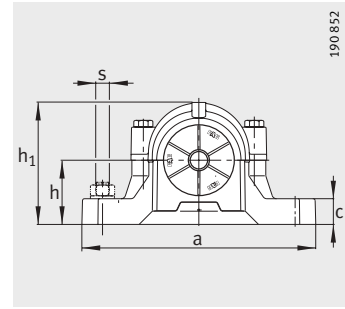
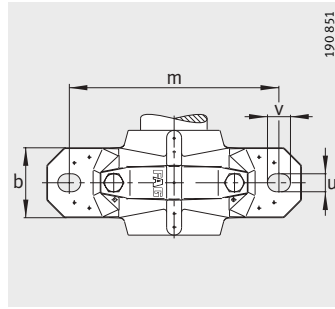

- ① Locating bearing
- ② Non-locating bearing

Dimension table (continued) · Dimensions in mm										
Designation										Mass m
Housing	Bearing	Lock- nut	Retain- ing plate	Locating ring 2 pieces	Double lip seal	Labyrinth ring with round cord	Felt seal	V ring seal	Cover	Housing ≈kg
SNV080-L	1208-TVH	KM8	MB8	FRM80/10,5	DH208	TSV208	FSV208	DHV208	DKV080	2,9
SNV080-L	20208-TVP	KM8	MB8	FRM80/10,5	DH208	TSV208	FSV208	DHV208	DKV080	2,9
SNV080-L	2208-TVH	KM8	MB8	FRM80/8	DH208	TSV208	FSV208	DHV208	DKV080	2,9
SNV080-L	22208-E1	KM8	MB8	FRM80/8	DH208	TSV208	FSV208	DHV208	DKV080	2,9
SNV090-L	1308-TVH	KM8	MB8	FRM90/9	DH308	TSV308	FSV308	DHV308	DKV090	3,1
SNV090-L	20308-TVP	KM8	MB8	FRM90/9	DH308	TSV308	FSV308	DHV308	DKV090	3,1
SNV090-L	21308-E1	KM8	MB8	FRM90/9	DH308	TSV308	FSV308	DHV308	DKV090	3,1
SNV090-L	2308-TVH	KM8	MB8	FRM90/4	DH308	TSV308	FSV308	DHV308	DKV090	3,1
SNV090-L	22308-E1	KM8	MB8	FRM90/4	DH308	TSV308	FSV308	DHV308	DKV090	3,1
SNV085-L	1209-TVH	KM9	MB9	FRM85/6	DH209	TSV209	FSV209	DHV209	DKV085	2,8
SNV085-L	20209-TVP	KM9	MB9	FRM85/6	DH209	TSV209	FSV209	DHV209	DKV085	2,8
SNV085-L	2209-TVH	KM9	MB9	FRM85/4	DH209	TSV209	FSV209	DHV209	DKV085	2,8
SNV085-L	22209-E1	KM9	MB9	FRM85/4	DH209	TSV209	FSV209	DHV209	DKV085	2,8
SNV100-L	1309-TVH	KM9	MB9	FRM100/9,5	DH309	TSV309	FSV309	DHV309	DKV100	4,3
SNV100-L	20309-TVP	KM9	MB9	FRM100/9,5	DH309	TSV309	FSV309	DHV309	DKV100	4,3
SNV100-L	21309-E1	KM9	MB9	FRM100/9,5	DH309	TSV309	FSV309	DHV309	DKV100	4,3
SNV100-L	2309-TVH	KM9	MB9	FRM100/4	DH309	TSV309	FSV309	DHV309	DKV100	4,3
SNV100-L	22309-E1	KM9	MB9	FRM100/4	DH309	TSV309	FSV309	DHV309	DKV100	4,3
SNV090-L	1210-TVH	KM10	MB10	FRM90/10,5	DH210	TSV210	FSV210	DHV210	DKV090	3,1
SNV090-L	20210-TVP	KM10	MB10	FRM90/10,5	DH210	TSV210	FSV210	DHV210	DKV090	3,1
SNV090-L	2210-TVH	KM10	MB10	FRM90/9	DH210	TSV210	FSV210	DHV210	DKV090	3,1
SNV090-L	22210-E1	KM10	MB10	FRM90/9	DH210	TSV210	FSV210	DHV210	DKV090	3,1
SNV110-L	1310-TVH	KM10	MB10	FRM110/10,5	DH310	TSV310	FSV310	DHV310	DKV110	4,9
SNV110-L	20310-TVP	KM10	MB10	FRM110/10,5	DH310	TSV310	FSV310	DHV310	DKV110	4,9
SNV110-L	21310-E1	KM10	MB10	FRM110/10,5	DH310	TSV310	FSV310	DHV310	DKV110	4,9
SNV110-L	2310-TVH	KM10	MB10	FRM110/4	DH310	TSV310	FSV310	DHV310	DKV110	4,9
SNV110-L	22310-E1	KM10	MB10	FRM110/4	DH310	TSV310	FSV310	DHV310	DKV110	4,9
SNV100-L	1211-TVH	KM11	MB11	FRM100/11,5	DH211	TSV211	FSV211	DHV211	DKV100	4,3
SNV100-L	20211-TVP	KM11	MB11	FRM100/11,5	DH211	TSV211	FSV211	DHV211	DKV100	4,3
SNV100-L	2211-TVH	KM11	MB11	FRM100/9,5	DH211	TSV211	FSV211	DHV211	DKV100	4,3
SNV100-L	22211-E1	KM11	MB11	FRM100/9,5	DH211	TSV211	FSV211	DHV211	DKV100	4,3
SNV120-L	1311-TVH	KM11	MB11	FRM120/11	DH311	TSV311	FSV311	DHV311	DKV120	6,1
SNV120-L	20311-TVP	KM11	MB11	FRM120/11	DH311	TSV311	FSV311	DHV311	DKV120	6,1
SNV120-L	21311-E1	KM11	MB11	FRM120/11	DH311	TSV311	FSV311	DHV311	DKV120	6,1
SNV120-L	2311-TVH	KM11	MB11	FRM120/4	DH311	TSV311	FSV311	DHV311	DKV120	6,1
SNV120-L	22311-E1	KM11	MB11	FRM120/4	DH311	TSV311	FSV311	DHV311	DKV120	6,1

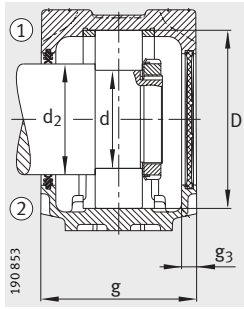

Double lip seal DH
Cover DKV

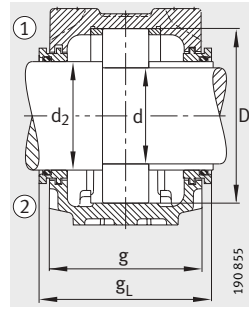

Labyrinth ring TSV

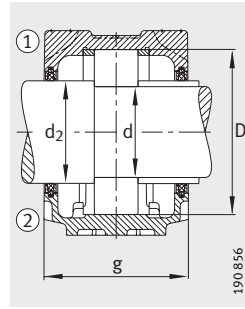

Felt seal FSV

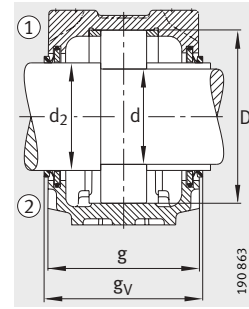

V ring seal DHV

Dimensions

d	a	g	h ₁	d ₂	b	c	D	g _L	g _V	g ₃	h	m	u	v	s	
															mm	inch
40	205	85	112	50	60	25	80	98	93	10,5	60	170	15	20	M12	1/2
40	205	85	112	50	60	25	80	98	93	10,5	60	170	15	20	M12	1/2
40	205	85	112	50	60	25	80	98	93	10,5	60	170	15	20	M12	1/2
40	205	85	112	50	60	25	80	98	93	10,5	60	170	15	20	M12	1/2
40	205	100	117	50	60	25	90	114	106	12,5	60	170	15	20	M12	1/2
40	205	100	117	50	60	25	90	114	106	12,5	60	170	15	20	M12	1/2
40	205	100	117	50	60	25	90	114	106	12,5	60	170	15	20	M12	1/2
40	205	100	117	50	60	25	90	114	106	12,5	60	170	15	20	M12	1/2
40	205	100	117	50	60	25	90	114	106	12,5	60	170	15	20	M12	1/2
45	205	87	114	55	60	25	85	101	93	12,5	60	170	15	20	M12	1/2
45	205	87	114	55	60	25	85	101	93	12,5	60	170	15	20	M12	1/2
45	205	87	114	55	60	25	85	101	93	12,5	60	170	15	20	M12	1/2
45	205	87	114	55	60	25	85	101	93	12,5	60	170	15	20	M12	1/2
45	255	105	133	55	70	28	100	119	111	12,5	70	210	18	23	M16	5/8
45	255	105	133	55	70	28	100	119	111	12,5	70	210	18	23	M16	5/8
45	255	105	133	55	70	28	100	119	111	12,5	70	210	18	23	M16	5/8
45	255	105	133	55	70	28	100	119	111	12,5	70	210	18	23	M16	5/8
45	255	105	133	55	70	28	100	119	111	12,5	70	210	18	23	M16	5/8
50	205	100	117	60	60	25	90	114	106	12,5	60	170	15	20	M12	1/2
50	205	100	117	60	60	25	90	114	106	12,5	60	170	15	20	M12	1/2
50	205	100	117	60	60	25	90	114	106	12,5	60	170	15	20	M12	1/2
50	205	100	117	60	60	25	90	114	106	12,5	60	170	15	20	M12	1/2
50	255	110	139	60	70	30	110	124	116	12,5	70	210	18	23	M16	5/8
50	255	110	139	60	70	30	110	124	116	12,5	70	210	18	23	M16	5/8
50	255	110	139	60	70	30	110	124	116	12,5	70	210	18	23	M16	5/8
50	255	110	139	60	70	30	110	124	116	12,5	70	210	18	23	M16	5/8
50	255	110	139	60	70	30	110	124	116	12,5	70	210	18	23	M16	5/8
55	255	105	133	65	70	28	100	119	111	12,5	70	210	18	23	M16	5/8
55	255	105	133	65	70	28	100	119	111	12,5	70	210	18	23	M16	5/8
55	255	105	133	65	70	28	100	119	111	12,5	70	210	18	23	M16	5/8
55	255	105	133	65	70	28	100	119	111	12,5	70	210	18	23	M16	5/8
55	275	115	155	65	80	30	120	129	121	12,5	80	230	18	23	M16	5/8
55	275	115	155	65	80	30	120	129	121	12,5	80	230	18	23	M16	5/8
55	275	115	155	65	80	30	120	129	121	12,5	80	230	18	23	M16	5/8
55	275	115	155	65	80	30	120	129	121	12,5	80	230	18	23	M16	5/8



Plummer block housings

SNV, split
For bearings with cylindrical bore

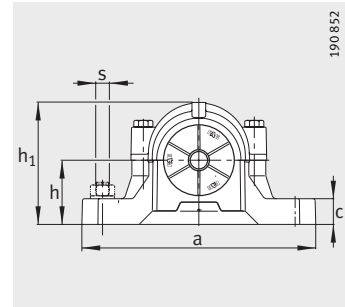
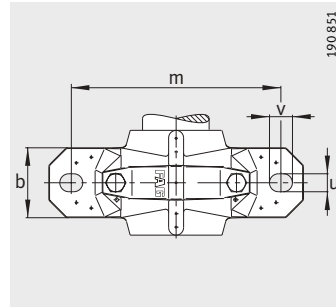

- ① Locating bearing
- ② Non-locating bearing

Dimension table (continued) · Dimensions in mm											
Designation											Mass m Housing ≈kg
Housing	Bearing	Lock- nut	Retain- ing plate	Locating ring 2 pieces	Double lip seal	Labyrinth ring with round cord	Felt seal	V ring seal	Taconite seal	Cover	
SNV110-L	1212-TVH	KM12	MB12	FRM110/13	DH212	TSV212	FSV212	DHV212	–	DKV110	4,9
SNV110-L	20212-TVP	KM12	MB12	FRM110/13	DH212	TSV212	FSV212	DHV212	–	DKV110	4,9
SNV110-L	2212-TVH	KM12	MB12	FRM110/10	DH212	TSV212	FSV212	DHV212	–	DKV110	4,9
SNV110-L	22212-E1	KM12	MB12	FRM110/10	DH212	TSV212	FSV212	DHV212	–	DKV110	4,9
SNV130-L	1312-TVH	KM12	MB12	FRM130/12,5	DH312	TSV312	FSV312	DHV312	TCV312	DKV130	6,8
SNV130-L	20312-TVP	KM12	MB12	FRM130/12,5	DH312	TSV312	FSV312	DHV312	TCV312	DKV130	6,8
SNV130-L	21312-E1	KM12	MB12	FRM130/12,5	DH312	TSV312	FSV312	DHV312	TCV312	DKV130	6,8
SNV130-L	2312-TVH	KM12	MB12	FRM130/5	DH312	TSV312	FSV312	DHV312	TCV312	DKV130	6,8
SNV130-L	22312-E1	KM12	MB12	FRM130/5	DH312	TSV312	FSV312	DHV312	TCV312	DKV130	6,8
SNV120-L	1213-TVH	KM13	MB13	FRM120/14	DH213	TSV213	FSV213	DHV213	–	DKV120	6,1
SNV120-L	20213-TVP	KM13	MB13	FRM120/14	DH213	TSV213	FSV213	DHV213	–	DKV120	6,1
SNV120-L	2213-TVH	KM13	MB13	FRM120/10	DH213	TSV213	FSV213	DHV213	–	DKV120	6,1
SNV120-L	22213-E1	KM13	MB13	FRM120/10	DH213	TSV213	FSV213	DHV213	–	DKV120	6,1
SNV140-L	1313-TVH	KM13	MB13	FRM140/12,5	DH313	TSV313	FSV313	DHV313	TCV313	DKV140	9,3
SNV140-L	20313-MB	KM13	MB13	FRM140/12,5	DH313	TSV313	FSV313	DHV313	TCV313	DKV140	9,3
SNV140-L	21313-E1	KM13	MB13	FRM140/12,5	DH313	TSV313	FSV313	DHV313	TCV313	DKV140	9,3
SNV140-L	2313-TVH	KM13	MB13	FRM140/5	DH313	TSV313	FSV313	DHV313	TCV313	DKV140	9,3
SNV140-L	22313-E1	KM13	MB13	FRM140/5	DH313	TSV313	FSV313	DHV313	TCV313	DKV140	9,3
SNV125-L	1214-TVH	KM14	MB14	FRM125/7,5	DH214	TSV214	FSV214	DHV214	TCV214	DKV150	6,5
SNV125-L	20214-TVP	KM14	MB14	FRM125/7,5	DH214	TSV214	FSV214	DHV214	TCV214	DKV150	6,5
SNV125-L	2214-M	KM14	MB14	FRM125/4	DH214	TSV214	FSV214	DHV214	TCV214	DKV150	6,5
SNV125-L	22214-E1	KM14	MB14	FRM125/4	DH214	TSV214	FSV214	DHV214	TCV214	DKV150	6,5
SNV150-L	1314-M	KM14	MB14	FRM150/13	DH214	TSV214	FSV214	DHV214	TCV214	DKV150	9,9
SNV150-L	20314-MB	KM14	MB14	FRM150/13	DH214	TSV214	FSV214	DHV214	TCV214	DKV150	9,9
SNV150-L	21314-E1	KM14	MB14	FRM150/13	DH214	TSV214	FSV214	DHV214	TCV214	DKV150	9,9
SNV150-L	2314-M	KM14	MB14	FRM150/5	DH214	TSV214	FSV214	DHV214	TCV214	DKV150	9,9
SNV150-L	22314-E1	KM14	MB14	FRM150/5	DH214	TSV214	FSV214	DHV214	TCV214	DKV150	9,9
SNV130-L	1215-TVH	KM15	MB15	FRM130/15,5	DH215	TSV215	FSV215	DHV215	–	DKV130	6,8
SNV130-L	20215-TVP	KM15	MB15	FRM130/15,5	DH215	TSV215	FSV215	DHV215	–	DKV130	6,8
SNV130-L	2215-TVH	KM15	MB15	FRM130/12,5	DH215	TSV215	FSV215	DHV215	–	DKV130	6,8
SNV130-L	22215-E1	KM15	MB15	FRM130/12,5	DH215	TSV215	FSV215	DHV215	–	DKV130	6,8
SNV160-L	1315-M	KM15	MB15	FRM160/14	DH315	TSV315	FSV315	DHV315	TCV315	DKV160	12,8
SNV160-L	20315-MB	KM15	MB15	FRM160/14	DH315	TSV315	FSV315	DHV315	TCV315	DKV160	12,8
SNV160-L	21315-E1	KM15	MB15	FRM160/14	DH315	TSV315	FSV315	DHV315	TCV315	DKV160	12,8
SNV160-L	2315-M	KM15	MB15	FRM160/5	DH315	TSV315	FSV315	DHV315	TCV315	DKV160	12,8
SNV160-L	22315-E1	KM15	MB15	FRM160/5	DH315	TSV315	FSV315	DHV315	TCV315	DKV160	12,8

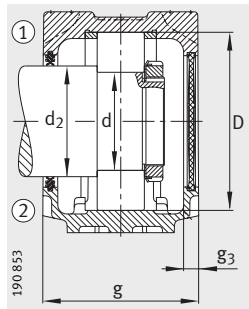

Double lip seal DH
Cover DKV

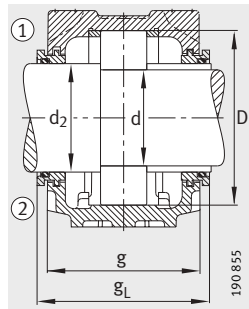

Labyrinth ring TSV

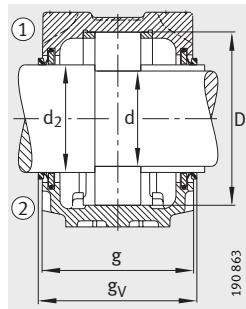

V ring seal DHV

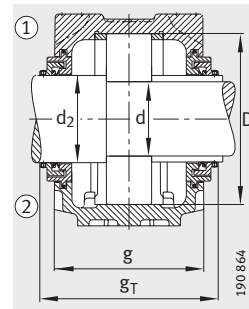

Taconite seal TCV

Dimensions

d	a	g	h ₁	d ₂	b	c	D	g _L	g _V	g _T	g ₃	h	m	u	v	s	
																mm	inch
60	255	110	139	70	70	30	110	124	120	–	12,5	70	210	18	23	M16	5/8
60	255	110	139	70	70	30	110	124	120	–	12,5	70	210	18	23	M16	5/8
60	255	110	139	70	70	30	110	124	120	–	12,5	70	210	18	23	M16	5/8
60	255	110	139	70	70	30	110	124	120	–	12,5	70	210	18	23	M16	5/8
60	280	120	161	70	80	30	130	134	130	158	12,5	80	230	18	23	M16	5/8
60	280	120	161	70	80	30	130	134	130	158	12,5	80	230	18	23	M16	5/8
60	280	120	161	70	80	30	130	134	130	158	12,5	80	230	18	23	M16	5/8
60	280	120	161	70	80	30	130	134	130	158	12,5	80	230	18	23	M16	5/8
60	280	120	161	70	80	30	130	134	130	158	12,5	80	230	18	23	M16	5/8
65	275	115	155	75	80	30	120	129	125	–	12,5	80	230	18	23	M16	5/8
65	275	115	155	75	80	30	120	129	125	–	12,5	80	230	18	23	M16	5/8
65	275	115	155	75	80	30	120	129	125	–	12,5	80	230	18	23	M16	5/8
65	275	115	155	75	80	30	120	129	125	–	12,5	80	230	18	23	M16	5/8
65	315	135	183	75	90	32	140	150,3	142,5	175,5	15	95	260	22	27	M20	3/4
65	315	135	183	75	90	32	140	150,3	142,5	175,5	15	95	260	22	27	M20	3/4
65	315	135	183	75	90	32	140	150,3	142,5	175,5	15	95	260	22	27	M20	3/4
65	315	135	183	75	90	32	140	150,3	142,5	175,5	15	95	260	22	27	M20	3/4
65	315	135	183	75	90	32	140	150,3	142,5	175,5	15	95	260	22	27	M20	3/4
70	275	105	158	80	80	30	125	120,3	110	143	15	80	230	18	23	M16	5/8
70	275	105	158	80	80	30	125	120,3	110	143	15	80	230	18	23	M16	5/8
70	275	105	158	80	80	30	125	120,3	110	143	15	80	230	18	23	M16	5/8
70	275	105	158	80	80	30	125	120,3	110	143	15	80	230	18	23	M16	5/8
70	320	140	189	80	90	32	150	155,3	147,5	180,5	15	95	260	22	27	M20	3/4
70	320	140	189	80	90	32	150	155,3	147,5	180,5	15	95	260	22	27	M20	3/4
70	320	140	189	80	90	32	150	155,3	147,5	180,5	15	95	260	22	27	M20	3/4
70	320	140	189	80	90	32	150	155,3	147,5	180,5	15	95	260	22	27	M20	3/4
70	320	140	189	80	90	32	150	155,3	147,5	180,5	15	95	260	22	27	M20	3/4
75	280	120	161	85	80	30	130	134	130	–	12,5	80	230	18	23	M16	5/8
75	280	120	161	85	80	30	130	134	130	–	12,5	80	230	18	23	M16	5/8
75	280	120	161	85	80	30	130	134	130	–	12,5	80	230	18	23	M16	5/8
75	280	120	161	85	80	30	130	134	130	–	12,5	80	230	18	23	M16	5/8
75	345	145	201	85	100	35	160	160,3	152,5	185,5	15	100	290	22	27	M20	3/4
75	345	145	201	85	100	35	160	160,3	152,5	185,5	15	100	290	22	27	M20	3/4
75	345	145	201	85	100	35	160	160,3	152,5	185,5	15	100	290	22	27	M20	3/4
75	345	145	201	85	100	35	160	160,3	152,5	185,5	15	100	290	22	27	M20	3/4
75	345	145	201	85	100	35	160	160,3	152,5	185,5	15	100	290	22	27	M20	3/4



Plummer block housings

SNV, split
For bearings with cylindrical bore

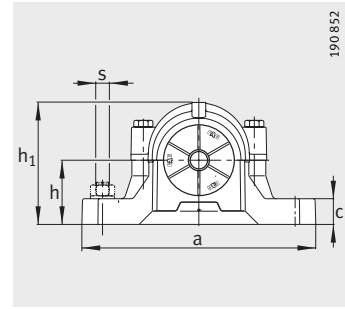
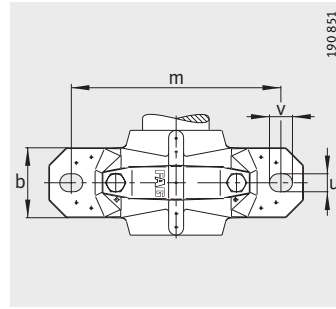

- ① Locating bearing
- ② Non-locating bearing

Dimension table (continued) · Dimensions in mm											
Designation											
Housing	Bearing	Lock-nut	Retain- ing plate	Locating ring 2 pieces	Double lip seal	Labyrinth ring with round cord	Felt seal	V ring seal	Taconite seal	Cover	Mass m Housing ≈kg
SNV140-L	1216-TVH	KM16	MB16	FRM140/16	DH216	TSV216	FSV216	DHV216	-	DKV140	9,3
SNV140-L	20216-TVP	KM16	MB16	FRM140/16	DH216	TSV216	FSV216	DHV216	-	DKV140	9,3
SNV140-L	2216-TVH	KM16	MB16	FRM140/12,5	DH216	TSV216	FSV216	DHV216	-	DKV140	9,3
SNV140-L	22216-E1	KM16	MB16	FRM140/12,5	DH216	TSV216	FSV216	DHV216	-	DKV140	9,3
SNV170-L	1316-M	KM16	MB16	FRM170/14,5	DH316	TSV316	FSV316	DHV316	TCV316	DKV170	14,4
SNV170-L	20316-MB	KM16	MB16	FRM170/14,5	DH316	TSV316	FSV316	DHV316	TCV316	DKV170	14,4
SNV170-L	21316-E1	KM16	MB16	FRM170/14,5	DH316	TSV316	FSV316	DHV316	TCV316	DKV170	14,4
SNV170-L	2316-M	KM16	MB16	FRM170/5	DH316	TSV316	FSV316	DHV316	TCV316	DKV170	14,4
SNV170-L	22316-E1	KM16	MB16	FRM170/5	DH316	TSV316	FSV316	DHV316	TCV316	DKV170	14,4
SNV150-L	1217-TVH	KM17	MB17	FRM150/16,5	DH217	TSV217	FSV217	DHV217	-	DKV150	9,9
SNV150-L	20217-MB	KM17	MB17	FRM150/16,5	DH217	TSV217	FSV217	DHV217	-	DKV150	9,9
SNV150-L	2217-M	KM17	MB17	FRM150/12,5	DH217	TSV217	FSV217	DHV217	-	DKV150	9,9
SNV150-L	22217-E1	KM17	MB17	FRM150/12,5	DH217	TSV217	FSV217	DHV217	-	DKV150	9,9
SNV180-L	1317-M	KM17	MB17	FRM180/14,5	DH317	TSV317	FSV317	DHV317	TCV317	DKV180	17
SNV180-L	20317-MB	KM17	MB17	FRM180/14,5	DH317	TSV317	FSV317	DHV317	TCV317	DKV180	17
SNV180-L	21317-E1	KM17	MB17	FRM180/14,5	DH317	TSV317	FSV317	DHV317	TCV317	DKV180	17
SNV180-L	2317-M	KM17	MB17	FRM180/5	DH317	TSV317	FSV317	DHV317	TCV317	DKV180	17
SNV180-L	22317-E1	KM17	MB17	FRM180/5	DH317	TSV317	FSV317	DHV317	TCV317	DKV180	17
SNV160-L	1218-TVH	KM18	MB18	FRM160/17,5	DH218	TSV218	FSV218	DHV218	-	DKV160	12,8
SNV160-L	20218-MB	KM18	MB18	FRM160/17,5	DH218	TSV218	FSV218	DHV218	-	DKV160	12,8
SNV160-L	2218-TVH	KM18	MB18	FRM160/12,5	DH218	TSV218	FSV218	DHV218	-	DKV160	12,8
SNV160-L	22218-E1	KM18	MB18	FRM160/12,5	DH218	TSV218	FSV218	DHV218	-	DKV160	12,8
SNV160-L	23218-E1	KM18	MB18	FRM160/6,3	DH218	TSV218	FSV218	DHV218	-	DKV160	12,8
SNV190-L	1318-M	KM18	MB18	FRM190/15,5	DH318	TSV318	FSV318	DHV318	-	DKV160	22
SNV190-L	20318-MB	KM18	MB18	FRM190/15,5	DH318	TSV318	FSV318	DHV318	-	DKV160	22
SNV190-L	21318-E1	KM18	MB18	FRM190/15,5	DH318	TSV318	FSV318	DHV318	-	DKV160	22
SNV190-L	2318-M	KM18	MB18	FRM190/5	DH318	TSV318	FSV318	DHV318	-	DKV160	22
SNV190-L	22318-E1	KM18	MB18	FRM190/5	DH318	TSV318	FSV318	DHV318	-	DKV160	22

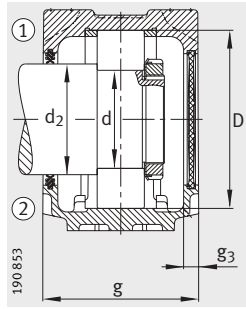

Double lip seal DH
Cover DKV

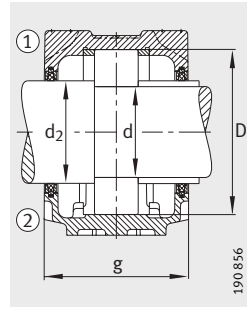

Felt seal FSV

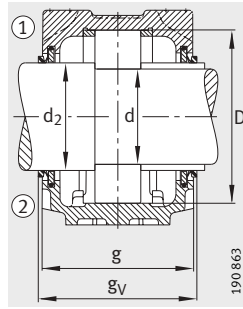

V ring seal DHV

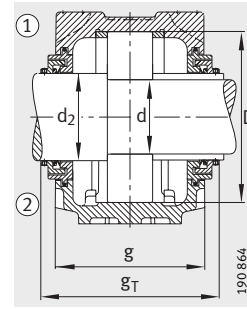

Taconite seal TCV

Dimensions

d	a	g	h ₁	d ₂	b	c	D	g _L	g _V	g _T	g ₃	h	m	u	v	s	
																mm	inch
80	315	135	183	90	90	32	140	150,3	142,5	–	15	95	260	22	27	M20	3/4
80	315	135	183	90	90	32	140	150,3	142,5	–	15	95	260	22	27	M20	3/4
80	315	135	183	90	90	32	140	150,3	142,5	–	15	95	260	22	27	M20	3/4
80	315	135	183	90	90	32	140	150,3	142,5	–	15	95	260	22	27	M20	3/4
80	345	150	219	90	100	35	170	167,3	157,5	192,5	16	112	290	22	27	M20	3/4
80	345	150	219	90	100	35	170	167,3	157,5	192,5	16	112	290	22	27	M20	3/4
80	345	150	219	90	100	35	170	167,3	157,5	192,5	16	112	290	22	27	M20	3/4
80	345	150	219	90	100	35	170	167,3	157,5	192,5	16	112	290	22	27	M20	3/4
80	345	150	219	90	100	35	170	167,3	157,5	192,5	16	112	290	22	27	M20	3/4
85	320	140	189	95	90	32	150	155,3	137,5	–	15	95	260	22	27	M20	3/4
85	320	140	189	95	90	32	150	155,3	137,5	–	15	95	260	22	27	M20	3/4
85	320	140	189	95	90	32	150	155,3	137,5	–	15	95	260	22	27	M20	3/4
85	320	140	189	95	90	32	150	155,3	137,5	–	15	95	260	22	27	M20	3/4
85	380	160	223	95	110	40	180	177,3	167,5	202,5	16	112	320	26	32	M24	7/8
85	380	160	223	95	110	40	180	177,3	167,5	202,5	16	112	320	26	32	M24	7/8
85	380	160	223	95	110	40	180	177,3	167,5	202,5	16	112	320	26	32	M24	7/8
85	380	160	223	95	110	40	180	177,3	167,5	202,5	16	112	320	26	32	M24	7/8
85	380	160	223	95	110	40	180	177,3	167,5	202,5	16	112	320	26	32	M24	7/8
90	345	145	201	100	100	35	160	160,3	152,5	–	15	100	290	22	27	M20	3/4
90	345	145	201	100	100	35	160	160,3	152,5	–	15	100	290	22	27	M20	3/4
90	345	145	201	100	100	35	160	160,3	152,5	–	15	100	290	22	27	M20	3/4
90	345	145	201	100	100	35	160	160,3	152,5	–	15	100	290	22	27	M20	3/4
90	345	145	201	100	100	35	160	160,3	152,5	–	15	100	290	22	27	M20	3/4
90	380	155	229	105	110	40	190	170,3	162,5	–	15	112	320	26	32	M24	7/8
90	380	155	229	105	110	40	190	170,3	162,5	–	15	112	320	26	32	M24	7/8
90	380	155	229	105	110	40	190	170,3	162,5	–	15	112	320	26	32	M24	7/8
90	380	155	229	105	110	40	190	170,3	162,5	–	15	112	320	26	32	M24	7/8
90	380	155	229	105	110	40	190	170,3	162,5	–	15	112	320	26	32	M24	7/8



Plummer block housings

SNV, split
For bearings with cylindrical bore

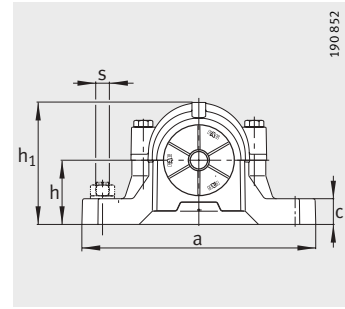
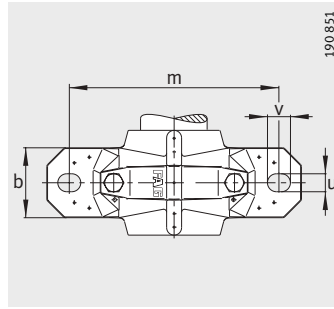

- ① Locating bearing
- ② Non-locating bearing

Dimension table (continued) · Dimensions in mm											
Designation											
Housing	Bearing	Lock-nut	Retaining plate	Locating ring 2 pieces	Double lip seal	Labyrinth ring with round cord	Felt seal	V ring seal	Taconite seal	Cover	Mass m Housing ≈kg
SNV170-L	1219-M	KM19	MB19	FRM170/18	DH219	TSV219	FSV219	DHV219	-	DKV170	14,4
SNV170-L	20219-MB	KM19	MB19	FRM170/18	DH219	TSV219	FSV219	DHV219	-	DKV170	14,4
SNV170-L	2219-M	KM19	MB19	FRM170/12,5	DH219	TSV219	FSV219	DHV219	-	DKV170	14,4
SNV170-L	22219-E1	KM19	MB19	FRM170/12,5	DH219	TSV219	FSV219	DHV219	-	DKV170	14,4
SNV200-L	1319-M	KM19	MB19	FRM200/17,5	DH319	TSV319	FSV319	DHV319	TCV319	DKV200	21
SNV200-L	20319-MB	KM19	MB19	FRM200/17,5	DH319	TSV319	FSV319	DHV319	TCV319	DKV200	21
SNV200-L	21319-E1-TVPB	KM19	MB19	FRM200/17,5	DH319	TSV319	FSV319	DHV319	TCV319	DKV200	21
SNV200-L	2319-M	KM19	MB19	FRM200/6,5	DH319	TSV319	FSV319	DHV319	TCV319	DKV200	21
SNV200-L	22319-E1	KM19	MB19	FRM200/6,5	DH319	TSV319	FSV319	DHV319	TCV319	DKV200	21
SNV180-L	1220-M	KM20	MB20	FRM180/18	DH220	TSV220	FSV220	DHV220	-	DKV180	17
SNV180-L	20220-MB	KM20	MB20	FRM180/18	DH220	TSV220	FSV220	DHV220	-	DKV180	17
SNV180-L	2220-M	KM20	MB20	FRM180/12	DH220	TSV220	FSV220	DHV220	-	DKV180	17
SNV180-L	22220-E1	KM20	MB20	FRM180/12	DH220	TSV220	FSV220	DHV220	-	DKV180	17
SNV180-L	23220-E1-TVPB	KM20	MB20	FRM180/4,85	DH220	TSV220	FSV220	DHV220	-	DKV180	17
SNV215-L ¹⁾	1320-M	KM20	MB20	FRM215/19,5	DH320	TSV320	FSV320	DHV320	TCV320	DKV215	24,5
SNV215-L ¹⁾	20320-MB	KM20	MB20	FRM215/19,5	DH320	TSV320	FSV320	DHV320	TCV320	DKV215	24,5
SNV215-L ¹⁾	21320-E1-TVPB	KM20	MB20	FRM215/19,5	DH320	TSV320	FSV320	DHV320	TCV320	DKV215	24,5
SNV215-L ¹⁾	2320-M	KM20	MB20	FRM215/6,5	DH320	TSV320	FSV320	DHV320	TCV320	DKV215	24,5
SNV215-L ¹⁾	22320-E1	KM20	MB20	FRM215/6,5	DH320	TSV320	FSV320	DHV320	TCV320	DKV215	24,5
SNV200-L	1222-M	KM22	MB22	FRM200/21	DH222	TSV222	FSV222	DHV222	-	DKV200	21
SNV200-L	20222-MB	KM22	MB22	FRM200/21	DH222	TSV222	FSV222	DHV222	-	DKV200	21
SNV200-L	2222-M	KM22	MB22	FRM200/13,5	DH222	TSV222	FSV222	DHV222	-	DKV200	21
SNV200-L	22222-E1	KM22	MB22	FRM200/13,5	DH222	TSV222	FSV222	DHV222	-	DKV200	21
SNV200-L	23222-E1-TVPB	KM22	MB22	FRM200/5,1	DH222	TSV222	FSV222	DHV222	-	DKV200	21
SNV240-L ¹⁾	1322-M	KM22	MB22	FRM240/20	DH222	TSV222	FSV222	DHV222	-	DKV200	32
SNV240-L ¹⁾	20322-MB	KM22	MB22	FRM240/20	DH222	TSV222	FSV222	DHV222	-	DKV200	32
SNV240-L ¹⁾	21322-E1-TVPB	KM22	MB22	FRM240/20	DH222	TSV222	FSV222	DHV222	-	DKV200	32
SNV240-L ¹⁾	2322-M	KM22	MB22	FRM240/5	DH222	TSV222	FSV222	DHV222	-	DKV200	32
SNV240-L ¹⁾	22322-E1	KM22	MB22	FRM240/5	DH222	TSV222	FSV222	DHV222	-	DKV200	32

¹⁾ Housing with ring bolt.

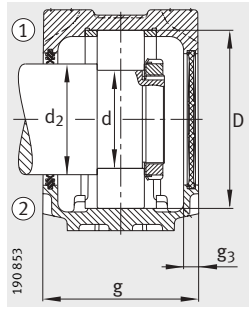

Double lip seal DH
Cover DKV

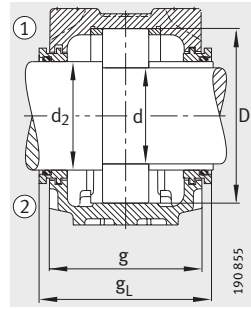

Labyrinth ring TSV

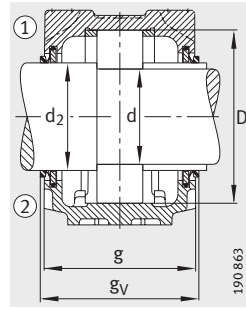

V ring seal DHV

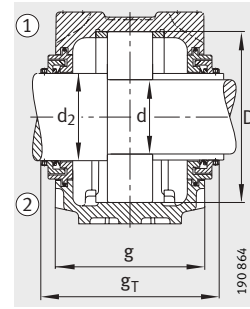

Taconite seal TCV

Dimensions

d	a	g	h ₁	d ₂	b	c	D	g _L	g _V	g _T	g ₃	h	m	u	v	s		
																	mm	inch
95	345	150	219	110	100	35	170	167,3	160,5	–	16	112	290	22	27	M20	3/4	
95	345	150	219	110	100	35	170	167,3	160,5	–	16	112	290	22	27	M20	3/4	
95	345	150	219	110	100	35	170	167,3	160,5	–	16	112	290	22	27	M20	3/4	
95	345	150	219	110	100	35	170	167,3	160,5	–	16	112	290	22	27	M20	3/4	
95	410	175	248	110	120	45	200	192,3	185,5	217,5	16	125	350	26	32	M24	7/8	
95	410	175	248	110	120	45	200	192,3	185,5	217,5	16	125	350	26	32	M24	7/8	
95	410	175	248	110	120	45	200	192,3	185,5	217,5	16	125	350	26	32	M24	7/8	
95	410	175	248	110	120	45	200	192,3	185,5	217,5	16	125	350	26	32	M24	7/8	
95	410	175	248	110	120	45	200	192,3	185,5	217,5	16	125	350	26	32	M24	7/8	
100	380	160	223	115	110	40	180	177,3	170,5	–	16	112	320	26	32	M24	7/8	
100	380	160	223	115	110	40	180	177,3	170,5	–	16	112	320	26	32	M24	7/8	
100	380	160	223	115	110	40	180	177,3	170,5	–	16	112	320	26	32	M24	7/8	
100	380	160	223	115	110	40	180	177,3	170,5	–	16	112	320	26	32	M24	7/8	
100	380	160	223	115	110	40	180	177,3	170,5	–	16	112	320	26	32	M24	7/8	
100	410	180	271	115	120	45	215	197,3	190,5	226,5	16	140	350	26	32	M24	7/8	
100	410	180	271	115	120	45	215	197,3	190,5	226,5	16	140	350	26	32	M24	7/8	
100	410	180	271	115	120	45	215	197,3	190,5	226,5	16	140	350	26	32	M24	7/8	
100	410	180	271	115	120	45	215	197,3	190,5	226,5	16	140	350	26	32	M24	7/8	
100	410	180	271	115	120	45	215	197,3	190,5	226,5	16	140	350	26	32	M24	7/8	
110	410	175	248	125	120	45	200	195,3	185,5	–	16	125	350	26	32	M24	7/8	
110	410	175	248	125	120	45	200	195,3	185,5	–	16	125	350	26	32	M24	7/8	
110	410	175	248	125	120	45	200	195,3	185,5	–	16	125	350	26	32	M24	7/8	
110	410	175	248	125	120	45	200	195,3	185,5	–	16	125	350	26	32	M24	7/8	
110	410	175	248	125	120	45	200	195,3	185,5	–	16	125	350	26	32	M24	7/8	
110	450	185	298	125	130	50	240	203,3	193,5	–	18	150	390	28	35	M24	1	
110	450	185	298	125	130	50	240	203,3	193,5	–	18	150	390	28	35	M24	1	
110	450	185	298	125	130	50	240	203,3	193,5	–	18	150	390	28	35	M24	1	
110	450	185	298	125	130	50	240	203,3	193,5	–	18	150	390	28	35	M24	1	
110	450	185	298	125	130	50	240	203,3	193,5	–	18	150	390	28	35	M24	1	



Plummer block housings

SNV, split
For bearings with cylindrical bore

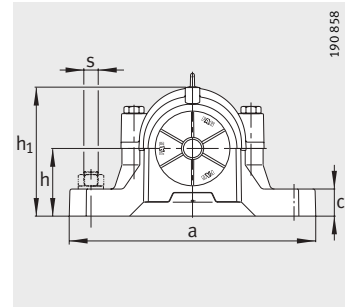
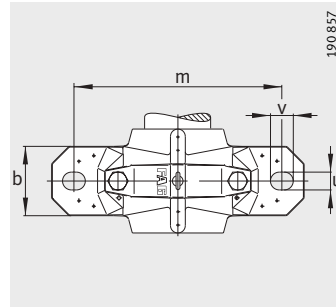

- ① Locating bearing
- ② Non-locating bearing

Dimension table (continued) · Dimensions in mm										
Designation										Mass m Housing
Housing	Bearing	Lock- nut	Retain- ing plate	Locating ring 2 pieces	Double lip seal	Labyrinth ring with round cord	Felt seal	V ring seal	Cover	≈kg
SNV215-L	20224-MB	KM24	MB24	FRM215/23	DH224	TSV224	FSV224	DHV224	DKV215	24,5
SNV215-L	22224-E1	KM24	MB24	FRM215/14	DH224	TSV224	FSV224	DHV224	DKV215	24,5
SNV215-L	23224-E1-TVPB	KM24	MB24	FRM215/5	DH224	TSV224	FSV224	DHV224	DKV215	24,5
SNV260-L	20324-MB	KM24	MB24	FRM260/20,5	DH224	TSV224	FSV224	DHV224	DKV215	48
SNV260-L	22324-E1	KM24	MB24	FRM260/5	DH224	TSV224	FSV224	DHV224	DKV215	48
SNV230-L	20226-MB	KM26	MB26	FRM230/25	DH226	TSV226	FSV226	DHV226	DKV230	30
SNV230-L	22226-E1	KM26	MB26	FRM230/13	DH226	TSV226	FSV226	DHV226	DKV230	30
SNV230-L	23226-E1-TVPB	KM26	MB26	FRM230/5	DH226	TSV226	FSV226	DHV226	DKV230	30
SNV280-L	20326-MB	KM26	MB26	FRM280/22,5	DH326	TSV326	FSV326	DHV326	DKV230	55
SNV280-L	22326-E1	KM26	MB26	FRM280/5	DH326	TSV326	FSV326	DHV326	DKV230	55
SNV250-L	20228-MB	KM28	MB28	FRM250/28	DH228	TSV228	FSV228	DHV228	DKV250	38
SNV250-L	22228-E1	KM28	MB28	FRM250/15	DH228	TSV228	FSV228	DHV228	DKV250	38
SNV250-L	23228-E1-TVPB	KM28	MB28	FRM250/5	DH228	TSV228	FSV228	DHV228	DKV250	38
SNV300-L	20328-MB	KM28	MB28	FRM300/25	DH328	TSV328	FSV328	DHV328	DKV250	70
SNV300-L	22328-E1	KM28	MB28	FRM300/5	DH328	TSV328	FSV328	DHV328	DKV250	70
SNV270-L	20230-MB	KM30	MB30	FRM270/30,5	DH230	TSV230	FSV230	DHV230	DKV270	45,5
SNV270-L	22230-E1	KM30	MB30	FRM270/16,5	DH230	TSV230	FSV230	DHV230	DKV270	45,5
SNV270-L	23230-E1-TVPB	KM30	MB30	FRM270/5	DH230	TSV230	FSV230	DHV230	DKV270	45,5
SNV320-L	20330-MB	KM30	MB30	FRM320/26,5	DH330	TSV330	FSV330	DHV330	DKV270	95
SNV320-L	22330-E1	KM30	MB30	FRM320/5	DH330	TSV330	FSV330	DHV330	DKV270	95
SNV290-L	20232-MB	KM32	MB32	FRM290/33	DH232	TSV232	FSV232	DHV232	DKV290	53,8
SNV290-L	22232-E1	KM32	MB32	FRM290/17	DH232	TSV232	FSV232	DHV232	DKV290	53,8
SNV290-L	23232-E1-TVPB	KM32	MB32	FRM290/5	DH232	TSV232	FSV232	DHV232	DKV290	53,8
SNV340-L	22332-MB	KM32	MB32	FRM340/5	DH332	TSV332	FSV332	DHV332	DKV290	115

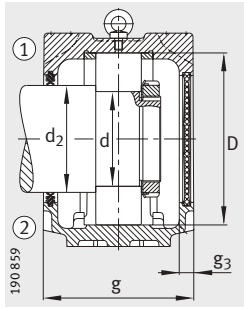

Double lip seal DH
Cover DKV

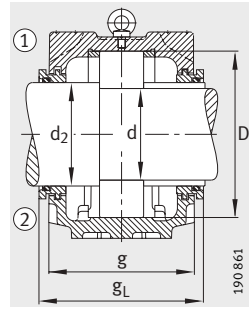

Labyrinth ring TSV

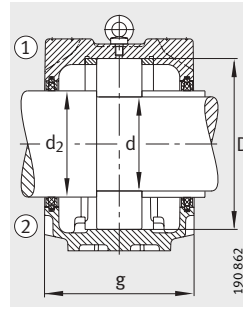

Felt seal FSV

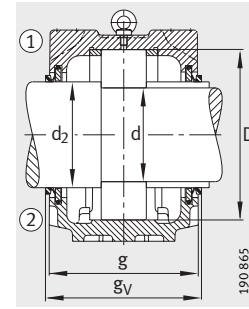

V ring seal DHV

Dimensions

d	a	g	h ₁	d ₂	b	c	D	g _L	g _V	g ₃	h	m	u	v	s		
																mm	inch
120	410	180	271	135	120	45	215	200,3	190,5	16	140	350	26	32	M24	7/8	
120	410	180	271	135	120	45	215	200,3	190,5	16	140	350	26	32	M24	7/8	
120	410	180	271	135	120	45	215	200,3	190,5	16	140	350	26	32	M24	7/8	
120	530	190	321	135	160	60	260	208,3	198,5	18	160	450	35	42	M30	1 1/4	
120	530	190	321	135	160	60	260	208,3	198,5	18	160	450	35	42	M30	1 1/4	
130	445	190	291	145	130	50	230	208,3	198,5	18	150	380	28	35	M24	1	
130	445	190	291	145	130	50	230	208,3	198,5	18	150	380	28	35	M24	1	
130	445	190	291	145	130	50	230	208,3	198,5	18	150	380	28	35	M24	1	
130	550	205	344	150	160	60	280	223,3	213,5	18	170	470	35	42	M30	1 1/4	
130	550	205	344	150	160	60	280	223,3	213,5	18	170	470	35	42	M30	1 1/4	
140	500	200	304	155	150	50	250	218,3	211,5	18	150	420	35	42	M30	1 1/4	
140	500	200	304	155	150	50	250	218,3	211,5	18	150	420	35	42	M30	1 1/4	
140	500	200	304	155	150	50	250	218,3	211,5	18	150	420	35	42	M30	1 1/4	
140	620	215	366	160	170	65	300	233,3	226,5	18	180	520	35	42	M30	1 1/4	
140	620	215	366	160	170	65	300	233,3	226,5	18	180	520	35	42	M30	1 1/4	
150	530	215	328	165	160	60	270	233,3	228,5	18	160	450	35	42	M30	1 1/4	
150	530	215	328	165	160	60	270	233,3	228,5	18	160	450	35	42	M30	1 1/4	
150	530	215	328	165	160	60	270	233,3	228,5	18	160	450	35	42	M30	1 1/4	
150	650	225	386	170	180	65	320	243,3	236,5	18	190	560	35	42	M30	1 1/4	
150	650	225	386	170	180	65	320	243,3	236,5	18	190	560	35	42	M30	1 1/4	
160	550	225	351	175	160	60	290	243,3	236,5	18	170	470	35	42	M30	1 1/4	
160	550	225	351	175	160	60	290	243,3	236,5	18	170	470	35	42	M30	1 1/4	
160	550	225	351	175	160	60	290	243,3	236,5	18	170	470	35	42	M30	1 1/4	
160	680	235	406	180	190	70	340	253,3	246,5	18	200	580	42	50	M36	1 1/2	



Plummer block housings

S30, split
For spherical roller bearings with tapered bore and adapter sleeve

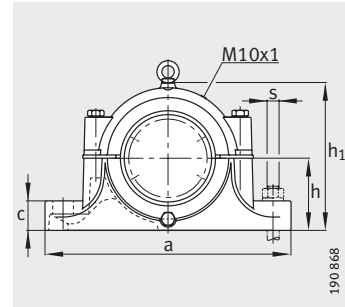
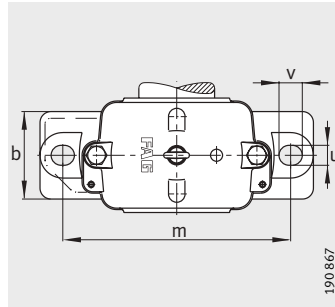

- ① Locating bearing
- ② Non-locating bearing

Dimension table · Dimensions in mm							
Designation					Felt strips		Mass m Housing ≈ kg
Housing	Bearing	Adapter sleeve	Locating ring	Cover	aXbXl mm	Quantity	
S3024-H-N-FZ-AB-L ¹⁾	23024-E1-K-TVPB	H3024	FRM180/10	DK127..135	10X8,5X195	2/4	16,5
S3026-H-N-FZ-AB-L ¹⁾	23026-E1-K-TVPB	H3026	FRM200/10	DK127..135	10X8,5X200	2/4	19,3
S3028-H-N-FZ-AB-L ¹⁾	23028-E1-K-TVPB	H3028	FRM210/10	DK147..155	14X11X225	2/4	24,6
S3030-H-N-FZ-AB-L ¹⁾	23030-E1-K-TVPB	H3030	FRM225/10	DK156..163	14X11X240	2/4	29
S3032-H-N-FZ-AB-L ¹⁾	23032-E1-K-TVPB	H3032	FRM240/10	DK166..182	14X11X250	2/4	37
S3034-H-N-FZ-AB-L	23034-E1-K-TVPB	H3034	FRM260/10	DK166..182	16X12X270	2/4	45
S3036-H-N-FZ-AB-L	23036-E1-K-TVPB	H3036	FRM280/10	DK185..197	16X12X285	2/4	65
S3038-H-N-FZ-AB-L	23038-E1-K-TVPB	H3038	FRM290/10	DK200..212	16X12X300	2/4	67
S3040-H-N-FZ-AB-L	23040-E1-K-TVPB	H3040	FRM310/10	DK200..212	16X12X315	2/4	72
S3044-H-N-FZ-AF-L	23044-K-MB	H3044X	–	–	16X12X350	2	98
S3044-H-N-FZ-AL-L	23044-K-MB	H3044X	–	–	16X12X350	2	98
S3044-H-N-FZ-BF-L	23044-K-MB	H3044X	–	–	16X12X350	4	98
S3044-H-N-FZ-BL-L	23044-K-MB	H3044X	–	–	16X12X350	4	98
S3048-H-N-FZ-AF-L	23048-K-MB	H3048	–	–	16X12X380	2	110
S3048-H-N-FZ-AL-L	23048-K-MB	H3048	–	–	16X12X380	2	110
S3048-H-N-FZ-BF-L	23048-K-MB	H3048	–	–	16X12X380	4	110
S3048-H-N-FZ-BL-L	23048-K-MB	H3048	–	–	16X12X380	4	110
S3052-H-N-FZ-AF-L	23052-K-MB	H3052X	–	–	16X12X410	2	148
S3052-H-N-FZ-AL-L	23052-K-MB	H3052X	–	–	16X12X410	2	148
S3052-H-N-FZ-BF-L	23052-K-MB	H3052X	–	–	16X12X410	4	148
S3052-H-N-FZ-BL-L	23052-K-MB	H3052X	–	–	16X12X410	4	148
S3056-H-N-FZ-AF-L	23056-B-K-MB	H3056	–	–	16X12X445	2	165
S3056-H-N-FZ-AL-L	23056-B-K-MB	H3056	–	–	16X12X445	2	165
S3056-H-N-FZ-BF-L	23056-B-K-MB	H3056	–	–	16X12X445	4	165
S3056-H-N-FZ-BL-L	23056-B-K-MB	H3056	–	–	16X12X445	4	165

¹⁾ Housing without ring bolt.

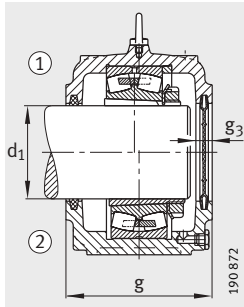

Cover DK,
locating bearings up to and including size S3040
with locating ring

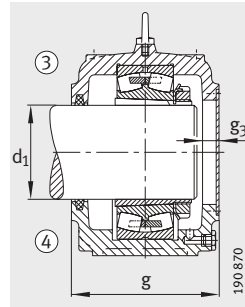
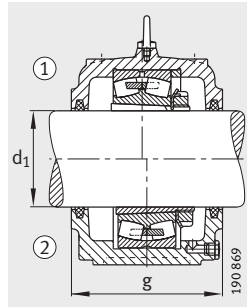

Design A
③ Locating bearing AF
④ Non-loc. bearing AL

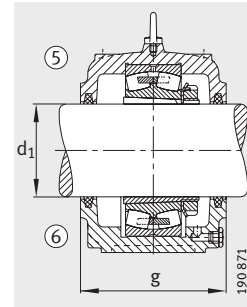

Design B
⑤ Locating bearing BF
⑥ Non-loc. bearing BL

Dimensions

d ₁	a	g	h ₁	b	c	g ₃	h	m	u	v	s	
											mm	inch
110	390	150	215	110	40	18	112	320	30	36	M24	1
115	420	160	239	120	45	18	125	350	30	36	M24	1
125	420	170	259	120	45	21	140	350	30	36	M24	1
135	460	175	278	130	45	21	150	380	30	36	M24	1
140	470	190	288	130	50	21	150	390	30	36	M24	1
150	540	200	320	160	55	25	160	450	36	48	M30	1 ¹ / ₈
160	560	210	340	160	55	25	170	470	36	48	M30	1 ¹ / ₈
170	560	210	353	160	55	25	170	470	36	48	M30	1 ¹ / ₈
180	615	235	373	170	60	25	180	515	36	48	M30	1 ¹ / ₈
200	690	255	408	190	70	25	200	580	42	50	M36	1 ³ / ₈
200	690	255	408	190	70	25	200	580	42	50	M36	1 ³ / ₈
200	690	255	408	190	70	–	200	580	42	50	M36	1 ³ / ₈
200	690	255	408	190	70	–	200	580	42	50	M36	1 ³ / ₈
220	720	265	433	200	75	30	210	610	42	50	M36	1 ³ / ₈
220	720	265	433	200	75	30	210	610	42	50	M36	1 ³ / ₈
220	720	265	433	200	75	–	210	610	42	50	M36	1 ³ / ₈
220	720	265	433	200	75	–	210	610	42	50	M36	1 ³ / ₈
240	820	285	485	220	80	30	240	680	52	70	M45	1 ³ / ₄
240	820	285	485	220	80	30	240	680	52	70	M45	1 ³ / ₄
240	820	285	485	220	80	–	240	680	52	70	M45	1 ³ / ₄
240	820	285	485	220	80	–	240	680	52	70	M45	1 ³ / ₄
260	860	295	505	230	80	30	250	720	52	70	M45	1 ³ / ₄
260	860	295	505	230	80	30	250	720	52	70	M45	1 ³ / ₄
260	860	295	505	230	80	–	250	720	52	70	M45	1 ³ / ₄
260	860	295	505	230	80	–	250	720	52	70	M45	1 ³ / ₄



Plummer block housings

S30, split

For spherical roller bearings
with tapered bore and adapter sleeve

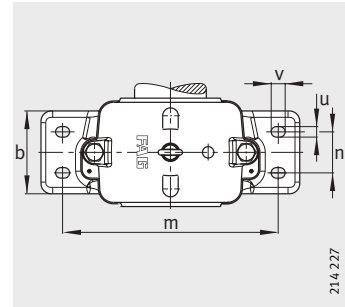

Dimension table (continued) · Dimensions in mm					
Designation			Felt strips		Mass m Housing ≈kg
Housing	Bearing	Adapter sleeve	aXbXl mm	Quantity	
S3060-H-N-FZ-AF-L	23060-K-MB	H3060	16X12X470	2	205
S3060-H-N-FZ-AL-L	23060-K-MB	H3060	16X12X470	2	205
S3060-H-N-FZ-BF-L	23060-K-MB	H3060	16X12X470	4	205
S3060-H-N-FZ-BL-L	23060-K-MB	H3060	16X12X470	4	205
S3064-H-N-FZ-AF-L	23064-K-MB	H3064-HG	16X12X505	2	235
S3064-H-N-FZ-AL-L	23064-K-MB	H3064-HG	16X12X505	2	235
S3064-H-N-FZ-BF-L	23064-K-MB	H3064-HG	16X12X505	4	235
S3064-H-N-FZ-BL-L	23064-K-MB	H3064-HG	16X12X505	4	235
S3068-H-N-FZ-AF-L	23068-K-MB	H3068-HG	16X12X535	2	280
S3068-H-N-FZ-AL-L	23068-K-MB	H3068-HG	16X12X535	2	280
S3068-H-N-FZ-BF-L	23068-K-MB	H3068-HG	16X12X535	4	280
S3068-H-N-FZ-BL-L	23068-K-MB	H3068-HG	16X12X535	4	280
S3072-H-N-FZ-AF-L	23072-K-MB	H3072-HG	16X12X565	2	340
S3072-H-N-FZ-AL-L	23072-K-MB	H3072-HG	16X12X565	2	340
S3072-H-N-FZ-BF-L	23072-K-MB	H3072-HG	16X12X565	4	340
S3072-H-N-FZ-BL-L	23072-K-MB	H3072-HG	16X12X565	4	340
S3076-H-N-FZ-AF-L	23076-B-K-MB	H3076-HG	16X12X600	2	400
S3076-H-N-FZ-AL-L	23076-B-K-MB	H3076-HG	16X12X600	2	400
S3076-H-N-FZ-BF-L	23076-B-K-MB	H3076-HG	16X12X600	4	400
S3076-H-N-FZ-BL-L	23076-B-K-MB	H3076-HG	16X12X600	4	400
S3080-H-N-FZ-AF-L	23080-K-MB	H3080-HG	16X12X630	2	460
S3080-H-N-FZ-AL-L	23080-K-MB	H3080-HG	16X12X630	2	460
S3080-H-N-FZ-BF-L	23080-K-MB	H3080-HG	16X12X630	4	460
S3080-H-N-FZ-BL-L	23080-K-MB	H3080-HG	16X12X630	4	460
S3084-H-N-FZ-AF-L	23084-B-K-MB	H3084X-HG	16X12X660	2	500
S3084-H-N-FZ-AL-L	23084-B-K-MB	H3084X-HG	16X12X660	2	500
S3084-H-N-FZ-BF-L	23084-B-K-MB	H3084X-HG	16X12X660	4	500
S3084-H-N-FZ-BL-L	23084-B-K-MB	H3084X-HG	16X12X660	4	500

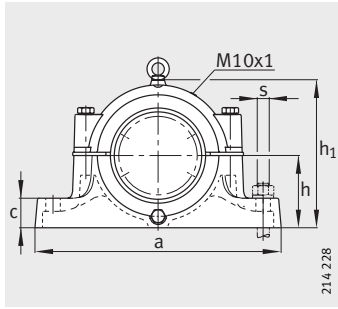

214 228

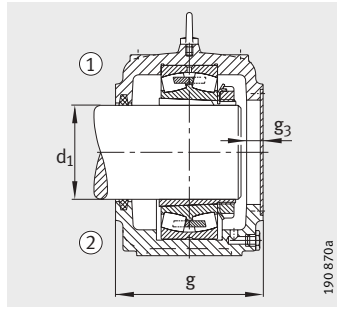

190 870a

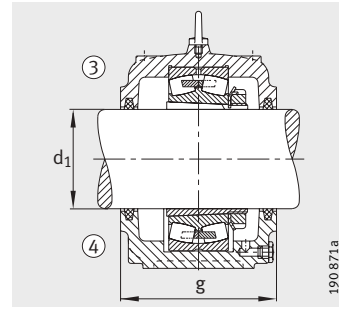

190 871a

Design A
 ① Locating bearing AF
 ② Non-locating bearing AL

Design B
 ③ Locating bearing BF
 ④ Non-locating bearing BL

Dimensions

d ₁	a	g	h ₁	b	c	g ₃	h	m	n	u	v	s	
												mm	inch
280	920	320	565	260	90	30	280	780	130	42	50	M36	1 ³ / ₈
280	920	320	565	260	90	30	280	780	130	42	50	M36	1 ³ / ₈
280	920	320	565	260	90	-	280	780	130	42	50	M36	1 ³ / ₈
280	920	320	565	260	90	-	280	780	130	42	50	M36	1 ³ / ₈
300	940	320	570	260	90	30	280	800	130	42	50	M36	1 ³ / ₈
300	940	320	570	260	90	30	280	800	130	42	50	M36	1 ³ / ₈
300	940	320	570	260	90	-	280	800	130	42	50	M36	1 ³ / ₈
300	940	320	570	260	90	-	280	800	130	42	50	M36	1 ³ / ₈
320	1000	340	615	280	95	30	300	860	140	42	50	M36	1 ³ / ₈
320	1000	340	615	280	95	30	300	860	140	42	50	M36	1 ³ / ₈
320	1000	340	615	280	95	-	300	860	140	42	50	M36	1 ³ / ₈
320	1000	340	615	280	95	-	300	860	140	42	50	M36	1 ³ / ₈
340	1060	345	655	280	95	30	320	900	140	42	50	M36	1 ³ / ₈
340	1060	345	655	280	95	30	320	900	140	42	50	M36	1 ³ / ₈
340	1060	345	655	280	95	-	320	900	140	42	50	M36	1 ³ / ₈
340	1060	345	655	280	95	-	320	900	140	42	50	M36	1 ³ / ₈
360	1060	380	675	280	100	30	330	900	140	42	50	M36	1 ³ / ₈
360	1060	380	675	280	100	30	330	900	140	42	50	M36	1 ³ / ₈
360	1060	380	675	280	100	-	330	900	140	42	50	M36	1 ³ / ₈
360	1060	380	675	280	100	-	330	900	140	42	50	M36	1 ³ / ₈
380	1100	400	715	325	120	30	350	950	160	42	50	M36	1 ³ / ₈
380	1100	400	715	325	120	30	350	950	160	42	50	M36	1 ³ / ₈
380	1100	400	715	325	120	-	350	950	160	42	50	M36	1 ³ / ₈
380	1100	400	715	325	120	-	350	950	160	42	50	M36	1 ³ / ₈
400	1160	430	750	340	120	30	375	980	170	42	50	M36	1 ³ / ₈
400	1160	430	750	340	120	30	375	980	170	42	50	M36	1 ³ / ₈
400	1160	430	750	340	120	-	375	980	170	42	50	M36	1 ³ / ₈
400	1160	430	750	340	120	-	375	980	170	42	50	M36	1 ³ / ₈



Plummer block housings

S30, split

For spherical roller bearings
with tapered bore and adapter sleeve

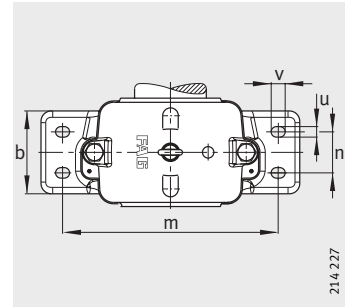

Dimension table (continued) · Dimensions in mm

Designation			Felt strips		Mass m Housing ≈kg
Housing	Bearing	Adapter sleeve	aXbXl mm	Quantity	
S3088-H-N-FZ-AF-L	23088-K-MB	H3088-HG	16X12X675	2	600
S3088-H-N-FZ-AL-L	23088-K-MB	H3088-HG	16X12X675	2	600
S3088-H-N-FZ-BF-L	23088-K-MB	H3088-HG	16X12X675	4	600
S3088-H-N-FZ-BL-L	23088-K-MB	H3088-HG	16X12X675	4	600
S3092-H-N-FZ-AF-L	23092-B-K-MB	H3092-HG	16X12X710	2	700
S3092-H-N-FZ-AL-L	23092-B-K-MB	H3092-HG	16X12X710	2	700
S3092-H-N-FZ-BF-L	23092-B-K-MB	H3092-HG	16X12X710	4	700
S3092-H-N-FZ-BL-L	23092-B-K-MB	H3092-HG	16X12X710	4	700
S3096-H-N-FZ-AF-L	23096-K-MB	H3096-HG	16X12X740	2	800
S3096-H-N-FZ-AL-L	23096-K-MB	H3096-HG	16X12X740	2	800
S3096-H-N-FZ-BF-L	23096-K-MB	H3096-HG	16X12X740	4	800
S3096-H-N-FZ-BL-L	23096-K-MB	H3096-HG	16X12X740	4	800

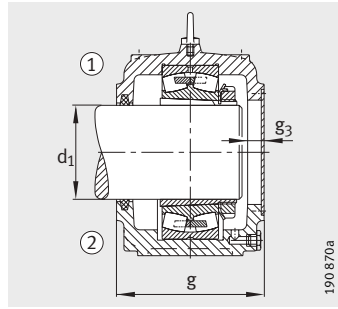
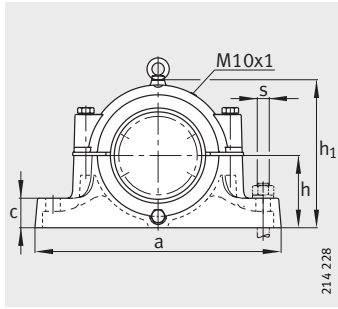

Design A
 ③ Locating bearing AF
 ④ Non-locating bearing AL

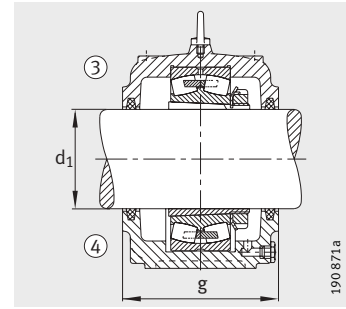

Design B
 ⑤ Locating bearing BF
 ⑥ Non-locating bearing BL

Dimensions

d ₁	a	g	h ₁	b	c	g ₃	h	m	n	u	v	s	
												mm	inch
410	1200	430	780	340	125	30	390	1020	170	42	50	M36	1 ³ / ₈
410	1200	430	780	340	125	30	390	1020	170	42	50	M36	1 ³ / ₈
410	1200	430	780	340	125	–	390	1020	170	42	50	M36	1 ³ / ₈
410	1200	430	780	340	125	–	390	1020	170	42	50	M36	1 ³ / ₈
430	1260	440	805	360	130	30	400	1080	180	56	75	M48	1 ⁷ / ₈
430	1260	440	805	360	130	30	400	1080	180	56	75	M48	1 ⁷ / ₈
430	1260	440	805	360	130	–	400	1080	180	56	75	M48	1 ⁷ / ₈
430	1260	440	805	360	130	–	400	1080	180	56	75	M48	1 ⁷ / ₈
450	1380	440	825	380	190	30	410	1180	190	56	75	M48	1 ⁷ / ₈
450	1380	440	825	380	190	30	410	1180	190	56	75	M48	1 ⁷ / ₈
450	1380	440	825	380	190	–	410	1180	190	56	75	M48	1 ⁷ / ₈
450	1380	440	825	380	190	–	410	1180	190	56	75	M48	1 ⁷ / ₈



Plummer block housings

SD31, split
For spherical roller bearings with tapered bore and adapter sleeve

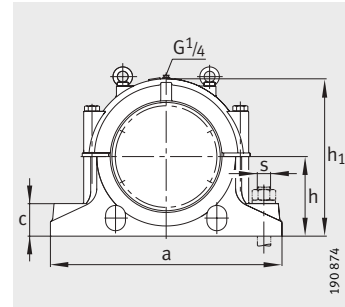
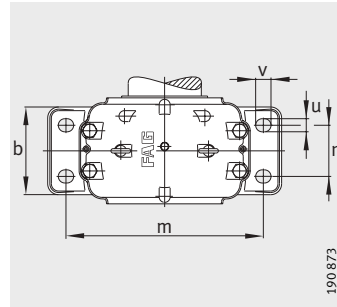

- ① Locating bearing
- ② Non-locating bearing

Dimension table · Dimensions in mm							
Designation							Mass m Housing ≈kg
Housing	Bearing	Adapter sleeve	Locating ring		Labyrinth ring with round cord		
				Quantity		Quantity	
SD3134-H-TS-A-L	23134-E1-K-TVPB	H3134	FRM280/10	2	TS34	1	70
SD3134-H-TS-B-L	23134-E1-K-TVPB	H3134	FRM280/10	2	TS34	2	70
SD3136-H-TS-A-L	23136-E1-K-TVPB	H3136	FRM300/10	2	TS36	1	78
SD3136-H-TS-B-L	23136-E1-K-TVPB	H3136	FRM300/10	2	TS36	2	78
SD3138-H-TS-A-L	23138-E1-K-TVPB	H3138	FRM320/10	2	TS38	1	95
SD3138-H-TS-B-L	23138-E1-K-TVPB	H3138	FRM320/10	2	TS38	2	95
SD3140-H-TS-A-L	23140-B-K-MB	H3140	FRM340/10	2	TS40	1	120
SD3140-H-TS-B-L	23140-B-K-MB	H3140	FRM340/10	2	TS40	2	120
SD3144-H-TS-AF-L	23144-B-K-MB	H3144X	–	–	TS44	1	135
SD3144-H-TS-AL-L	23144-B-K-MB	H3144X	–	–	TS44	1	135
SD3144-H-TS-BF-L	23144-B-K-MB	H3144X	–	–	TS44	2	135
SD3144-H-TS-BL-L	23144-B-K-MB	H3144X	–	–	TS44	2	135
SD3148-H-TS-AF-L	23148-B-K-MB	H3148X	–	–	TS48	1	175
SD3148-H-TS-AL-L	23148-B-K-MB	H3148X	–	–	TS48	1	175
SD3148-H-TS-BF-L	23148-B-K-MB	H3148X	–	–	TS48	2	175
SD3148-H-TS-BL-L	23148-B-K-MB	H3148X	–	–	TS48	2	175
SD3152-H-TS-AF-L	23152-K-MB	H3152X	–	–	TS52	1	210
SD3152-H-TS-AL-L	23152-K-MB	H3152X	–	–	TS52	1	210
SD3152-H-TS-BF-L	23152-K-MB	H3152X	–	–	TS52	2	210
SD3152-H-TS-BL-L	23152-K-MB	H3152X	–	–	TS52	2	210
SD3156-H-TS-AF-L	23156-B-K-MB	H3156X	–	–	TS56	1	240
SD3156-H-TS-AL-L	23156-B-K-MB	H3156X	–	–	TS56	1	240
SD3156-H-TS-BF-L	23156-B-K-MB	H3156X	–	–	TS56	2	240
SD3156-H-TS-BL-L	23156-B-K-MB	H3156X	–	–	TS56	2	240
SD3160-H-TS-AF-L	23160-B-K-MB	H3160-HG	–	–	TS60	1	290
SD3160-H-TS-AL-L	23160-B-K-MB	H3160-HG	–	–	TS60	1	290
SD3160-H-TS-BF-L	23160-B-K-MB	H3160-HG	–	–	TS60	2	290
SD3160-H-TS-BL-L	23160-B-K-MB	H3160-HG	–	–	TS60	2	290
SD3164-H-TS-AF-L	23164-K-MB	H3164-HG	–	–	TS64	1	330
SD3164-H-TS-AL-L	23164-K-MB	H3164-HG	–	–	TS64	1	330
SD3164-H-TS-BF-L	23164-K-MB	H3164-HG	–	–	TS64	2	330
SD3164-H-TS-BL-L	23164-K-MB	H3164-HG	–	–	TS64	2	330

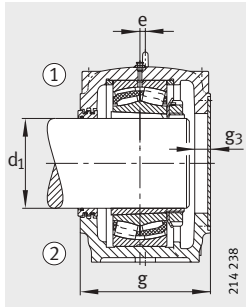

Design A (TS-A)

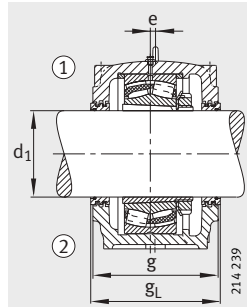

Design B (TS-B)

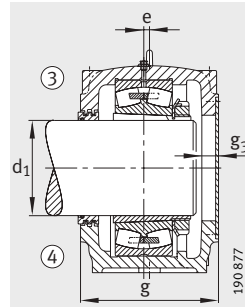

Design A
 ③ Locating bear. TS-AF
 ④ Non-loc. bear. TS-AL

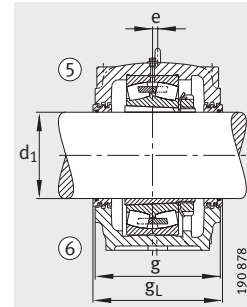

Design B
 ⑤ Locating bear. TS-BF
 ⑥ Non-loc. bear. TS-BL

Dimensions

d ₁	a	g	h ₁	b	c	e	g _L	g ₃	h	m	n	u	v	s	
														mm	inch
150	510	230	335	180	70	14	—	35	170	430	100	30	36	M24	1
150	510	230	335	180	70	14	240	—	170	430	100	30	36	M24	1
160	530	240	355	190	75	15	—	35	180	450	110	30	36	M24	1
160	530	240	355	190	75	15	250	—	180	450	110	30	36	M24	1
170	560	260	375	210	80	10	—	35	190	480	120	30	36	M24	1
170	560	260	375	210	80	10	270	—	190	480	120	30	36	M24	1
180	610	280	410	230	85	10	—	35	210	510	130	36	42	M30	1 ¹ / ₈
180	610	280	410	230	85	10	290	—	210	510	130	36	42	M30	1 ¹ / ₈
200	640	290	435	240	90	12	—	35	220	540	140	36	42	M30	1 ¹ / ₈
200	640	290	435	240	90	12	—	35	220	540	140	36	42	M30	1 ¹ / ₈
200	640	290	435	240	90	12	300	—	220	540	140	36	42	M30	1 ¹ / ₈
200	640	290	435	240	90	12	300	—	220	540	140	36	42	M30	1 ¹ / ₈
220	700	310	475	260	95	12	—	35	240	600	150	36	42	M30	1 ¹ / ₈
220	700	310	475	260	95	12	—	35	240	600	150	36	42	M30	1 ¹ / ₈
220	700	310	475	260	95	12	320	—	240	600	150	36	42	M30	1 ¹ / ₈
220	700	310	475	260	95	12	320	—	240	600	150	36	42	M30	1 ¹ / ₈
240	770	320	515	280	100	13	—	35	260	650	160	42	52	M36	1 ³ / ₈
240	770	320	515	280	100	13	—	35	260	650	160	42	52	M36	1 ³ / ₈
240	770	320	515	280	100	13	330	—	260	650	160	42	52	M36	1 ³ / ₈
240	770	320	515	280	100	13	330	—	260	650	160	42	52	M36	1 ³ / ₈
260	790	320	550	280	105	16	—	35	280	670	160	42	52	M36	1 ³ / ₈
260	790	320	550	280	105	16	—	35	280	670	160	42	52	M36	1 ³ / ₈
260	790	320	550	280	105	16	330	—	280	670	160	42	52	M36	1 ³ / ₈
260	790	320	550	280	105	16	330	—	280	670	160	42	52	M36	1 ³ / ₈
280	830	350	590	310	110	22	—	35	300	710	190	42	52	M36	1 ³ / ₈
280	830	350	590	310	110	22	—	35	300	710	190	42	52	M36	1 ³ / ₈
280	830	350	590	310	110	22	360	—	300	710	190	42	52	M36	1 ³ / ₈
280	830	350	590	310	110	22	360	—	300	710	190	42	52	M36	1 ³ / ₈
300	880	370	630	330	115	23	—	35	320	750	200	42	52	M36	1 ³ / ₈
300	880	370	630	330	115	23	—	35	320	750	200	42	52	M36	1 ³ / ₈
300	880	370	630	330	115	23	380	—	320	750	200	42	52	M36	1 ³ / ₈
300	880	370	630	330	115	23	380	—	320	750	200	42	52	M36	1 ³ / ₈



Plummer block housings

SD31, split
For spherical roller bearings with tapered bore and adapter sleeve

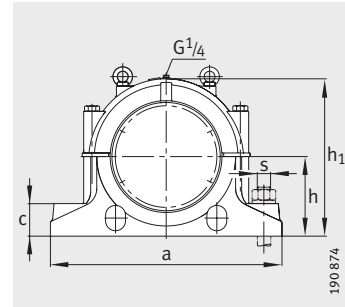
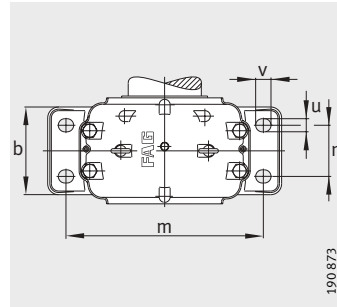

Dimension table (continued) · Dimensions in mm					
Designation					Mass m Housing ≈ kg
Housing	Bearing	Adapter sleeve	Labyrinth ring with round cord		
				Quantity	
SD3168-H-TS-AF-L	23168-B-K-MB	H3168-HG	TS68	1	380
SD3168-H-TS-AL-L	23168-B-K-MB	H3168-HG	TS68	1	380
SD3168-H-TS-BF-L	23168-B-K-MB	H3168-HG	TS68	2	380
SD3168-H-TS-BL-L	23168-B-K-MB	H3168-HG	TS68	2	380
SD3172-H-TS-AF-L	23172-K-MB	H3172-HG	TS72	1	420
SD3172-H-TS-AL-L	23172-K-MB	H3172-HG	TS72	1	420
SD3172-H-TS-BF-L	23172-K-MB	H3172-HG	TS72	2	420
SD3172-H-TS-BL-L	23172-K-MB	H3172-HG	TS72	2	420
SD3176-H-TS-AF-L	23176-K-MB	H3176-HG	TS76	1	490
SD3176-H-TS-AL-L	23176-K-MB	H3176-HG	TS76	1	490
SD3176-H-TS-BF-L	23176-K-MB	H3176-HG	TS76	2	490
SD3176-H-TS-BL-L	23176-K-MB	H3176-HG	TS76	2	490
SD3180-H-TS-AF-L	23180-B-K-MB	H3180-HG	TS80	1	570
SD3180-H-TS-AL-L	23180-B-K-MB	H3180-HG	TS80	1	570
SD3180-H-TS-BF-L	23180-B-K-MB	H3180-HG	TS80	2	570
SD3180-H-TS-BL-L	23180-B-K-MB	H3180-HG	TS80	2	570
SD3184-H-TS-AF-L	23184-K-MB	H3184-HG	TS84	1	610
SD3184-H-TS-AL-L	23184-K-MB	H3184-HG	TS84	1	610
SD3184-H-TS-BF-L	23184-K-MB	H3184-HG	TS84	2	610
SD3184-H-TS-BL-L	23184-K-MB	H3184-HG	TS84	2	610
SD3188-H-TS-AF-L	23188-K-MB	H3188-HG	TS88	1	770
SD3188-H-TS-AL-L	23188-K-MB	H3188-HG	TS88	1	770
SD3188-H-TS-BF-L	23188-K-MB	H3188-HG	TS88	2	770
SD3188-H-TS-BL-L	23188-K-MB	H3188-HG	TS88	2	770
SD3192-H-TS-AF-L	23192-K-MB	H3192-HG	TS92	1	830
SD3192-H-TS-AL-L	23192-K-MB	H3192-HG	TS92	1	830
SD3192-H-TS-BF-L	23192-K-MB	H3192-HG	TS92	2	830
SD3192-H-TS-BL-L	23192-K-MB	H3192-HG	TS92	2	830
SD3196-H-TS-AF-L	23196-K-MB	H3196-HG	TS96	1	930
SD3196-H-TS-AL-L	23196-K-MB	H3196-HG	TS96	1	930
SD3196-H-TS-BF-L	23196-K-MB	H3196-HG	TS96	2	930
SD3196-H-TS-BL-L	23196-K-MB	H3196-HG	TS96	2	930

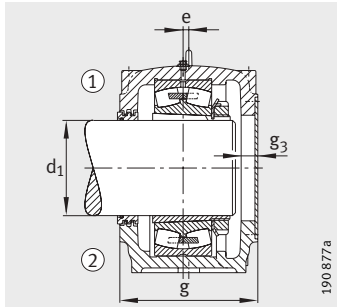

Design A
 ① Locating bearing TS-AF
 ② Non-locating bearing TS-AL

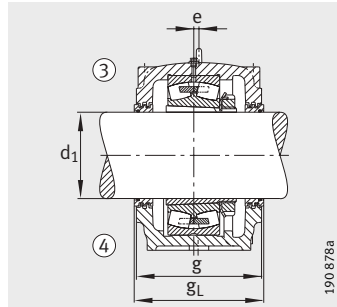

Design B
 ③ Locating bearing TS-BF
 ④ Non-locating bearing TS-BL

Dimensions

d ₁	a	g	h ₁	b	c	e	g _L	g ₃	h	m	n	u	v	s	
														mm	inch
320	950	400	675	360	120	24	-	35	340	810	220	42	52	M36	1 ³ / ₈
320	950	400	675	360	120	24	-	35	340	810	220	42	52	M36	1 ³ / ₈
320	950	400	675	360	120	24	410	-	340	810	220	42	52	M36	1 ³ / ₈
320	950	400	675	360	120	24	410	-	340	810	220	42	52	M36	1 ³ / ₈
340	1000	400	695	360	120	30	-	35	350	840	220	42	52	M36	1 ³ / ₈
340	1000	400	695	360	120	30	-	35	350	840	220	42	52	M36	1 ³ / ₈
340	1000	400	695	360	120	30	410	-	350	840	220	42	52	M36	1 ³ / ₈
340	1000	400	695	360	120	30	410	-	350	840	220	42	52	M36	1 ³ / ₈
360	1040	400	715	360	120	30	-	35	360	870	220	42	52	M36	1 ³ / ₈
360	1040	400	715	360	120	30	-	35	360	870	220	42	52	M36	1 ³ / ₈
360	1040	400	715	360	120	30	410	-	360	870	220	42	52	M36	1 ³ / ₈
360	1040	400	715	360	120	30	410	-	360	870	220	42	52	M36	1 ³ / ₈
380	1120	430	755	390	125	30	-	35	380	950	240	48	60	M42	1 ⁵ / ₈
380	1120	430	755	390	125	30	-	35	380	950	240	48	60	M42	1 ⁵ / ₈
380	1120	430	755	390	125	30	440	-	380	950	240	48	60	M42	1 ⁵ / ₈
380	1120	430	755	390	125	30	440	-	380	950	240	48	60	M42	1 ⁵ / ₈
400	1170	460	810	420	130	35	-	35	410	1000	260	48	60	M42	1 ⁵ / ₈
400	1170	460	810	420	130	35	-	35	410	1000	260	48	60	M42	1 ⁵ / ₈
400	1170	460	810	420	130	35	470	-	410	1000	260	48	60	M42	1 ⁵ / ₈
400	1170	460	810	420	130	35	470	-	410	1000	260	48	60	M42	1 ⁵ / ₈
410	1220	460	835	430	135	35	-	35	420	1030	260	48	60	M42	1 ⁵ / ₈
410	1220	460	835	430	135	35	-	35	420	1030	260	48	60	M42	1 ⁵ / ₈
410	1220	460	835	430	135	35	470	-	420	1030	260	48	60	M42	1 ⁵ / ₈
410	1220	460	835	430	135	35	470	-	420	1030	260	48	60	M42	1 ⁵ / ₈
430	1280	470	875	440	145	35	-	35	440	1070	260	48	60	M42	1 ⁵ / ₈
430	1280	470	875	440	145	35	-	35	440	1070	260	48	60	M42	1 ⁵ / ₈
430	1280	470	875	440	145	35	480	-	440	1070	260	48	60	M42	1 ⁵ / ₈
430	1280	470	875	440	145	35	480	-	440	1070	260	48	60	M42	1 ⁵ / ₈
450	1330	470	920	440	155	45	-	35	460	1110	260	66	80	M56	2 ¹ / ₄
450	1330	470	920	440	155	45	-	35	460	1110	260	66	80	M56	2 ¹ / ₄
450	1330	470	920	440	155	45	480	-	460	1110	260	66	80	M56	2 ¹ / ₄
450	1330	470	920	440	155	45	480	-	460	1110	260	66	80	M56	2 ¹ / ₄



Plummer block housings

LOE, split
For spherical roller bearings with cylindrical bore

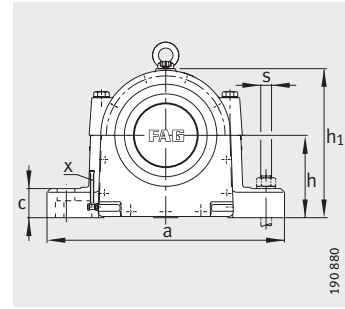
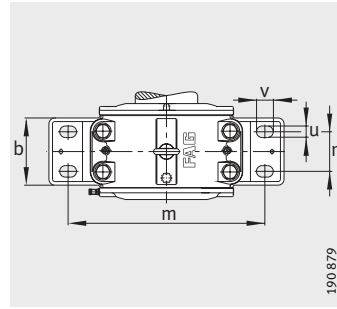

Dimension table · Dimensions in mm					Oil quantity	Oil level	Mass
Designation					Initial filling	Height	m
Housing		Bearing	Shaft nut	Retaining plate	l	x mm	Housing ≈kg
Locating bearings	Non-locating bearings						
LOE310-N-AF-L	LOE310-N-AL-L	22310-E1	KM10	MB10	0,9	50– 65	30
LOE310-N-BF-L	LOE310-N-BL-L	22310-E1	KM10	MB10	0,9	50– 65	30
LOE312-N-AF-L	LOE312-N-AL-L	22312-E1	KM12	MB12	1	50– 65	35
LOE312-N-BF-L	LOE312-N-BL-L	22312-E1	KM12	MB12	1	50– 65	35
LOE314-N-AF-L	LOE314-N-AL-L	22314-E1	KM14	MB14	1,4	50– 65	45
LOE314-N-BF-L	LOE314-N-BL-L	22314-E1	KM14	MB14	1,4	50– 65	45
LOE316-N-AF-L	LOE316-N-AL-L	22316-E1	KM16	MB16	1,6	55– 70	60
LOE316-N-BF-L	LOE316-N-BL-L	22316-E1	KM16	MB16	1,6	55– 70	60
LOE217-N-AF-L	LOE217-N-AL-L	22217-E1	KM17	MB17	1,4	50– 65	45
LOE217-N-BF-L	LOE217-N-BL-L	22217-E1	KM17	MB17	1,4	50– 65	45
LOE218-N-AF-L	LOE218-N-AL-L	22218-E1	KM18	MB18	1,5	45– 60	47
LOE218-N-BF-L	LOE218-N-BL-L	22218-E1	KM18	MB18	1,5	45– 60	47
LOE318-N-AF-L	LOE318-N-AL-L	22318-E1	KM18	MB18	2,3	65– 85	73
LOE318-N-BF-L	LOE318-N-BL-L	22318-E1	KM18	MB18	2,3	65– 85	73
LOE219-N-AF-L	LOE219-N-AL-L	22219-E1	KM19	MB19	1,6	55– 70	60
LOE219-N-BF-L	LOE219-N-BL-L	22219-E1	KM19	MB19	1,6	55– 70	60
LOE220-N-AF-L	LOE220-N-AL-L	22220-E1	KM20	MB20	1,7	50– 65	67
LOE220-N-BF-L	LOE220-N-BL-L	22220-E1	KM20	MB20	1,7	50– 65	67
LOE320-N-AF-L	LOE320-N-AL-L	22320-E1	KM20	MB20	2,4	55– 75	81
LOE320-N-BF-L	LOE320-N-BL-L	22320-E1	KM20	MB20	2,4	55– 75	81
LOE222-N-AF-L	LOE222-N-AL-L	22222-E1	KM22	MB22	2,1	50– 70	74
LOE222-N-BF-L	LOE222-N-BL-L	22222-E1	KM22	MB22	2,1	50– 70	74
LOE322-N-AF-L	LOE322-N-AL-L	22322-E1	KM22	MB22	2,4	45– 65	100
LOE322-N-BF-L	LOE322-N-BL-L	22322-E1	KM22	MB22	2,4	45– 65	100
LOE224-N-AF-L	LOE224-N-AL-L	22224-E1	KM24	MB24	2,3	50– 70	80
LOE224-N-BF-L	LOE224-N-BL-L	22224-E1	KM24	MB24	2,3	50– 70	80
LOE324-N-AF-L	LOE324-N-AL-L	22324-E1	KM24	MB24	4,2	65– 90	130
LOE324-N-BF-L	LOE324-N-BL-L	22324-E1	KM24	MB24	4,2	65– 90	130
LOE226-N-AF-L	LOE226-N-AL-L	22226-E1	KM26	MB26	2,3	55– 75	93
LOE226-N-BF-L	LOE226-N-BL-L	22226-E1	KM26	MB26	2,3	55– 75	93
LOE326-N-AF-L	LOE326-N-AL-L	22326-E1	KM26	MB26	3,7	75–105	142
LOE326-N-BF-L	LOE326-N-BL-L	22326-E1	KM26	MB26	3,7	75–105	142

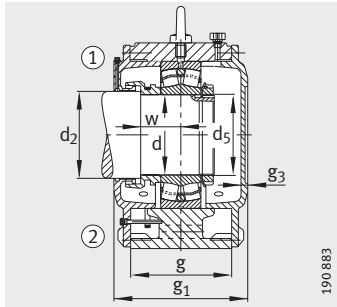

Design A
 ① Locating bearing AF
 ② Non-locating bearing AL

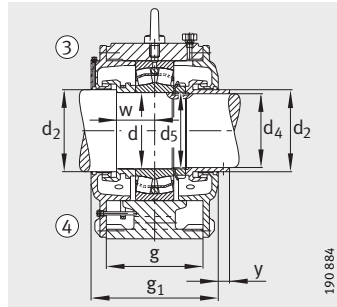

Design B
 ③ Locating bearing BF
 ④ Non-locating bearing BL

Dimensions

d	a	g ₁	h ₁	d ₂	d ₄	d ₅	w	b	c	g	g ₃	h	m	n	u	v	s	y
50	350	210	205	55	-	M50X2	52	125	40	135	18	115	290	75	20	30	M16	-
50	350	210	205	55	47	M50X2	52	125	40	135	-	115	290	75	20	30	M16	15
60	370	220	220	65	-	M60X2	55	130	45	140	18	125	310	80	20	30	M16	-
60	370	220	220	65	57	M60X2	55	130	45	140	-	125	310	80	20	30	M16	15
70	410	225	240	75	-	M70X2	62	150	48	160	18	135	340	80	25	35	M20	-
70	410	225	240	75	67	M70X2	62	150	48	160	-	135	340	80	25	35	M20	15
80	490	250	270	85	-	M80X2	67	160	50	170	18	150	400	80	30	45	M24	-
80	490	250	270	85	77	M80X2	67	160	50	170	-	150	400	80	30	45	M24	15
85	410	225	240	90	-	M85X2	62	150	48	160	18	135	340	80	25	35	M20	-
85	410	225	240	90	82	M85X2	62	150	48	160	-	135	340	80	25	35	M20	15
90	410	225	245	95	-	M90X2	61	150	48	160	17,5	135	340	80	25	35	M20	-
90	410	225	245	95	87	M90X2	61	150	48	160	-	135	340	80	25	35	M20	15
90	500	250	305	95	-	M90X2	72	165	55	175	18	175	420	80	30	45	M24	-
90	500	250	305	95	87	M90X2	72	165	55	175	-	175	420	80	30	45	M24	15
95	490	250	270	100	-	M95X2	67	160	50	170	18	150	400	80	30	45	M24	-
95	490	250	270	100	92	M95X2	67	160	50	170	-	150	400	80	30	45	M24	15
100	490	250	270	110	-	M100X2	60	160	50	170	20	150	400	80	30	45	M24	-
100	490	250	270	110	97	M100X2	60	160	50	170	-	150	400	80	30	45	M24	15
100	550	250	320	106	-	M100X2	72	165	55	175	18	175	440	80	36	50	M30	-
100	550	250	320	106	97	M100X2	72	165	55	175	-	175	440	80	36	50	M30	15
110	510	250	300	116	-	M110X2	70	165	50	175	18	165	420	80	30	45	M24	-
110	510	250	300	116	107	M110X2	70	165	50	175	-	165	420	80	30	45	M24	15
110	570	270	335	120	-	M110X2	77	180	65	190	20	180	460	95	36	50	M30	-
110	570	270	335	120	107	M110X2	77	180	65	190	-	180	460	95	36	50	M30	15
120	550	250	320	126	-	M120X2	72	165	55	175	18	175	440	80	36	50	M30	-
120	550	250	320	126	117	M120X2	72	165	55	175	-	175	440	80	36	50	M30	15
120	660	300	390	126	-	M120X2	90	200	75	210	18	220	530	110	42	60	M36	-
120	660	300	390	126	117	M120X2	90	200	75	210	-	220	530	110	42	60	M36	15
130	570	260	345	136	-	M130X2	77	175	65	185	18	190	460	90	36	50	M30	-
130	570	260	345	136	127	M130X2	77	175	65	185	-	190	460	90	36	50	M30	15
130	660	315	420	140	-	M130X2	86	200	80	220	18	235	530	110	42	60	M36	-
130	660	315	420	140	127	M130X2	86	200	80	220	-	235	530	110	42	60	M36	15



Plummer block housings

LOE, split
For spherical roller bearings with cylindrical bore

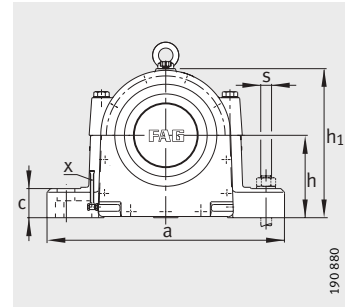
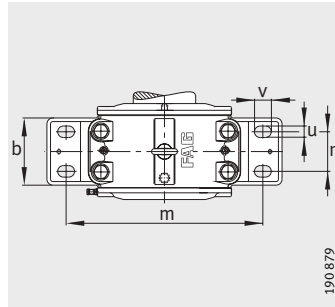

Dimension table (continued) · Dimensions in mm					Oil quantity	Oil level	Mass
Designation					Initial filling	Height	m
Housing		Bearing	Shaft nut	Retaining plate	l	x mm	Housing ≈kg
Locating bearings	Non-locating bearings						
LOE228-N-AF-L	LOE228-N-AL-L	22228-E1	KM28	MB28	3,7	55– 70	100
LOE228-N-BF-L	LOE228-N-BL-L	22228-E1	KM28	MB28	3,7	55– 70	100
LOE328-N-AF-L	LOE328-N-AL-L	22328-E1	KM28	MB28	6,7	80–110	170
LOE328-N-BF-L	LOE328-N-BL-L	22328-E1	KM28	MB28	6,7	80–110	170
LOE230-N-AF-L	LOE230-N-AL-L	22230-E1	KM30	MB30	4,2	65– 90	125
LOE230-N-BF-L	LOE230-N-BL-L	22230-E1	KM30	MB30	4,2	65– 90	125
LOE330-N-AF-L	LOE330-N-AL-L	22330-E1	KM30	MB30	6,2	75–110	200
LOE330-N-BF-L	LOE330-N-BL-L	22330-E1	KM30	MB30	6,2	75–110	200
LOE232-N-AF-L	LOE232-N-AL-L	22232-E1	KM32	MB32	4,7	60– 80	136
LOE232-N-BF-L	LOE232-N-BL-L	22232-E1	KM32	MB32	4,7	60– 80	136
LOE332-N-AF-L	LOE332-N-AL-L	22332-MB	KM32	MB32	7	80–105	240
LOE332-N-BF-L	LOE332-N-BL-L	22332-MB	KM32	MB32	7	80–105	240
LOE234-N-AF-L	LOE234-N-AL-L	22234-E1	KM34	MB34	6	90–105	160
LOE234-N-BF-L	LOE234-N-BL-L	22234-E1	KM34	MB34	6	90–105	160
LOE334-N-AF-L	LOE334-N-AL-L	22334-MB	KM34	MB34	7,2	80–105	270
LOE334-N-BF-L	LOE334-N-BL-L	22334-MB	KM34	MB34	7,2	80–105	270
LOE236-N-AF-L	LOE236-N-AL-L	22236-E1	KM36	MB36	6	75–110	200
LOE236-N-BF-L	LOE236-N-BL-L	22236-E1	KM36	MB36	6	75–110	200
LOE336-N-AF-L	LOE336-N-AL-L	22336-MB	KM36	MB36	7,4	80–105	330
LOE336-N-BF-L	LOE336-N-BL-L	22336-MB	KM36	MB36	7,4	80–105	330
LOE238-N-AF-L	LOE238-N-AL-L	22238-MB	KM38	MB38	7,2	70–100	230
LOE238-N-BF-L	LOE238-N-BL-L	22238-MB	KM38	MB38	7,2	70–100	230
LOE240-N-AF-L	LOE240-N-AL-L	22240-B-MB	KM40	MB40	7,2	75–100	250
LOE240-N-BF-L	LOE240-N-BL-L	22240-B-MB	KM40	MB40	7,2	75–100	250
LOE244-N-AF-L	LOE244-N-AL-L	22244-B-MB	HM44T	MB44	8,2	80–110	310
LOE244-N-BF-L	LOE244-N-BL-L	22244-B-MB	HM44T	MB44	8,2	80–110	310
LOE248-N-AF-L	LOE248-N-AL-L	22248-B-MB	HM48T	MB48	8,4	100–125	385
LOE248-N-BF-L	LOE248-N-BL-L	22248-B-MB	HM48T	MB48	8,4	100–125	385

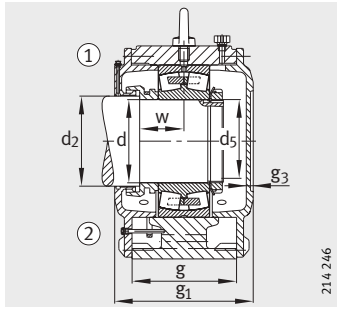

Design A
 ① Locating bearing AF
 ② Non-locating bearing AL

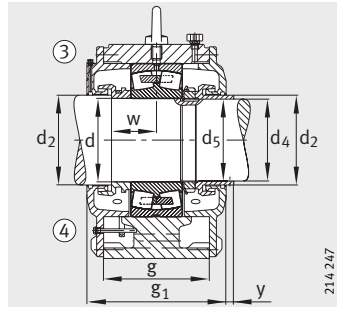

Design B
 ③ Locating bearing BF
 ④ Non-locating bearing BL

Dimensions

d	a	g ₁	h ₁	d ₂	d ₄	d ₅	w	b	c	g	g ₃	h	m	n	u	v	s	y
140	570	260	355	150	-	M140X2	73	175	65	180	18	190	460	100	36	50	M30	-
140	570	260	355	150	137	M140X2	73	175	65	180	-	190	460	100	36	50	M30	22
140	710	325	450	146	-	M140X2	95	220	85	230	19,5	260	580	125	42	60	M36	-
140	710	325	450	146	137	M140X2	95	220	85	230	-	260	580	125	42	60	M36	15
150	660	275	395	156	-	M150X2	82	190	70	200	18	220	530	100	42	60	M36	-
150	660	275	395	156	147	M150X2	82	190	70	200	-	220	530	100	42	60	M36	15
150	760	335	465	160	-	M150X2	95	200	85	240	18	265	630	125	42	60	M36	-
150	760	335	465	160	147	M150X2	95	200	85	240	-	265	630	125	42	60	M36	15
160	660	290	400	170	-	M160X3	80	200	70	210	20	220	530	110	42	60	M36	-
160	660	290	400	170	155	M160X3	80	200	70	210	-	220	530	110	42	60	M36	22
160	820	350	485	166	-	M160X3	100	240	90	250	20	270	670	130	48	70	M42	-
160	820	350	485	166	155	M160X3	100	240	90	250	-	270	670	130	48	70	M42	15
170	710	300	460	176	-	M170X3	90	200	85	210	18	260	580	110	42	60	M36	-
170	710	300	460	176	165	M170X3	90	200	85	210	-	260	580	110	42	60	M36	15
170	830	350	510	180	-	M170X3	105	240	90	255	18	280	670	130	48	70	M42	-
170	830	350	510	180	165	M170X3	105	240	90	255	-	280	670	130	48	70	M42	15
180	710	300	465	190	-	M180X3	90	200	85	210	20	260	580	110	42	60	M36	-
180	710	300	465	190	175	M180X3	90	200	85	210	-	260	580	110	42	60	M36	22
180	840	360	530	190	-	M180X3	108	240	90	260	20	290	680	130	48	70	M42	-
180	840	360	530	190	175	M180X3	108	240	90	260	-	290	680	130	48	70	M42	15
190	820	350	485	196	-	M190X3	95	240	90	250	20	270	670	130	48	70	M42	-
190	820	350	485	196	185	M190X3	95	240	90	250	-	270	670	130	48	70	M42	15
200	830	344	510	210	-	M200X3	100	240	90	260	20	280	670	130	48	70	M42	-
200	830	344	510	210	195	M200X3	100	240	90	260	-	280	670	130	48	70	M42	15
220	880	380	565	230	-	Tr220X4	108	240	105	280	20	310	720	130	48	70	M42	-
220	880	380	565	230	212	Tr220X4	108	240	105	280	-	310	720	130	48	70	M42	15
240	980	400	615	260	-	Tr240X4	120	280	120	300	20	340	820	165	48	70	M42	-
240	980	400	615	260	235	Tr240X4	120	280	120	300	-	340	820	165	48	70	M42	22



Plummer block housings

LOE, split
For spherical roller bearings with tapered bore and adapter sleeve

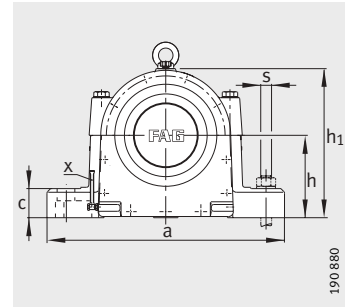
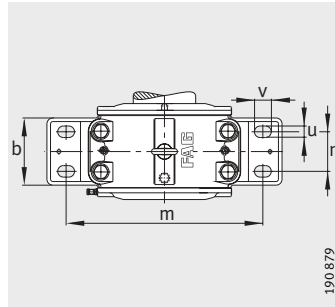

Dimension table · Dimensions in mm				Oil quantity	Oil level	Mass
Designation				Initial filling l	Height x mm	m Housing ≈kg
Housing	Bearing	Adapter sleeve				
Locating bearings	Non-locating bearings					
LOE614-N-AF-L	LOE614-N-AL-L	22314-E1-K	H2314	1,4	50– 65	45
LOE614-N-BF-L	LOE614-N-BL-L	22314-E1-K	H2314	1,4	50– 65	45
LOE616-N-AF-L	LOE616-N-AL-L	22316-E1-K	H2316	1,6	55– 70	60
LOE616-N-BF-L	LOE616-N-BL-L	22316-E1-K	H2316	1,6	55– 70	60
LOE517-N-AF-L	LOE517-N-AL-L	22217-E1-K	H317	1,4	50– 65	45
LOE517-N-BF-L	LOE517-N-BL-L	22217-E1-K	H317	1,4	50– 65	45
LOE518-N-AF-L	LOE518-N-AL-L	22218-E1-K	H318	1,5	45– 60	47
LOE518-N-BF-L	LOE518-N-BL-L	22218-E1-K	H318	1,5	45– 60	47
LOE618-N-AF-L	LOE618-N-AL-L	22318-E1-K	H2318	2,3	65– 85	73
LOE618-N-BF-L	LOE618-N-BL-L	22318-E1-K	H2318	2,3	65– 85	73
LOE519-N-AF-L	LOE519-N-AL-L	22219-E1-K	H319	1,6	55– 70	60
LOE519-N-BF-L	LOE519-N-BL-L	22219-E1-K	H319	1,6	55– 70	60
LOE520-N-AF-L	LOE520-N-AL-L	22220-E1-K	H320	1,7	50– 65	67
LOE520-N-BF-L	LOE520-N-BL-L	22220-E1-K	H320	1,7	50– 65	67
LOE620-N-AF-L	LOE620-N-AL-L	22320-E1-K	H2320	2,4	55– 75	81
LOE620-N-BF-L	LOE620-N-BL-L	22320-E1-K	H2320	2,4	55– 75	81
LOE522-N-AF-L	LOE522-N-AL-L	22222-E1-K	H322	2,1	50– 70	74
LOE522-N-BF-L	LOE522-N-BL-L	22222-E1-K	H322	2,1	50– 70	74
LOE622-N-AF-L	LOE622-N-AL-L	22322-E1-K	H2322	2,4	45– 65	100
LOE622-N-BF-L	LOE622-N-BL-L	22322-E1-K	H2322	2,4	45– 65	100
LOE524-N-AF-L	LOE524-N-AL-L	22224-E1-K	H3124	2,3	50– 70	80
LOE524-N-BF-L	LOE524-N-BL-L	22224-E1-K	H3124	2,3	50– 70	80
LOE624-N-AF-L	LOE624-N-AL-L	22324-E1-K	H2324	4,2	65– 90	130
LOE624-N-BF-L	LOE624-N-BL-L	22324-E1-K	H2324	4,2	65– 90	130
LOE526-N-AF-L	LOE526-N-AL-L	22226-E1-K	H3126	2,3	55– 75	93
LOE526-N-BF-L	LOE526-N-BL-L	22226-E1-K	H3126	2,3	55– 75	93
LOE626-N-AF-L	LOE626-N-AL-L	22326-E1-K	H2326	3,7	75–105	142
LOE626-N-BF-L	LOE626-N-BL-L	22326-E1-K	H2326	3,7	75–105	142
LOE528-N-AF-L	LOE528-N-AL-L	22228-E1-K	H3128	3,7	55– 75	100
LOE528-N-BF-L	LOE528-N-BL-L	22228-E1-K	H3128	3,7	55– 75	100
LOE628-N-AF-L	LOE628-N-AL-L	22328-E1-K	H2328	6,7	80–110	170
LOE628-N-BF-L	LOE628-N-BL-L	22328-E1-K	H2328	6,7	80–110	170

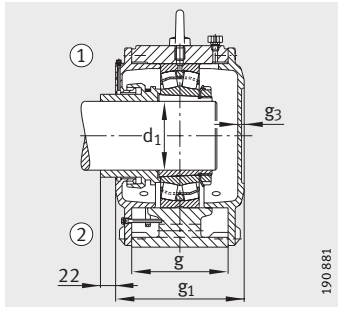

Design A
 ① Locating bearing AF
 ② Non-locating bearing AL

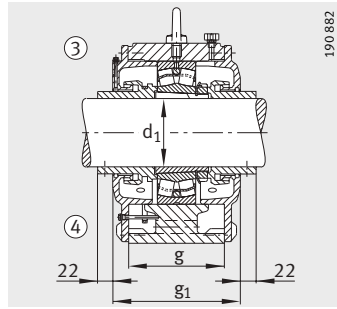

Design B
 ③ Locating bearing BF
 ④ Non-locating bearing BL

Dimensions

d_1	a	g_1	h_1	b	c	g	g_3	h	m	n	u	v	s
60	410	225	240	150	48	160	18	135	340	80	25	35	M20
60	410	225	240	150	48	160	–	135	340	80	25	35	M20
70	490	250	270	160	50	170	18	150	400	80	30	45	M24
70	490	250	270	160	50	170	–	150	400	80	30	45	M24
75	410	225	240	150	48	160	18	135	340	80	25	35	M20
75	410	225	240	150	48	160	–	135	340	80	25	35	M20
80	410	225	245	150	48	160	17,5	135	340	80	25	35	M20
80	410	225	245	150	48	160	–	135	340	80	25	35	M20
80	500	250	305	165	55	175	18	175	420	80	30	45	M24
80	500	250	305	165	55	175	–	175	420	80	30	45	M24
85	490	250	270	160	50	170	18	150	400	80	30	45	M24
85	490	250	270	160	50	170	–	150	400	80	30	45	M24
90	490	250	270	160	50	170	20	150	400	80	30	45	M24
90	490	250	270	160	50	170	–	150	400	80	30	45	M24
90	550	250	320	165	55	175	18	175	440	80	36	50	M30
90	550	250	320	165	55	175	–	175	440	80	36	50	M30
100	510	250	300	165	50	175	18	165	420	80	30	45	M24
100	510	250	300	165	50	175	–	165	420	80	30	45	M24
100	570	270	335	180	65	190	20	180	460	95	36	50	M30
100	570	270	335	180	65	190	–	180	460	95	36	50	M30
110	550	250	320	165	55	175	18	175	440	80	36	50	M30
110	550	250	320	165	55	175	–	175	440	80	36	50	M30
110	660	300	390	200	75	210	18	220	530	110	42	60	M36
110	660	300	390	200	75	210	–	220	530	110	42	60	M36
115	570	260	345	175	65	185	18	190	460	90	36	50	M30
115	570	260	345	175	65	185	–	190	460	90	36	50	M30
115	660	315	420	200	80	220	18	235	530	110	42	60	M36
115	660	315	420	200	80	220	–	235	530	110	42	60	M36
125	570	260	355	175	65	180	18	190	460	100	36	50	M30
125	570	260	355	175	65	180	–	190	460	100	36	50	M30
125	710	325	450	220	85	230	19,5	260	580	125	42	60	M36
125	710	325	450	220	85	230	–	260	580	125	42	60	M36



Plummer block housings

LOE, split
For spherical roller bearings with tapered bore and adapter sleeve

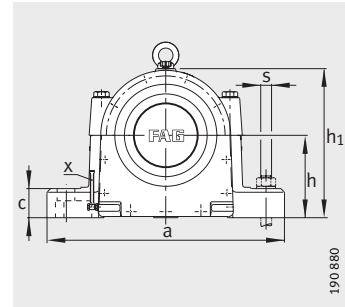
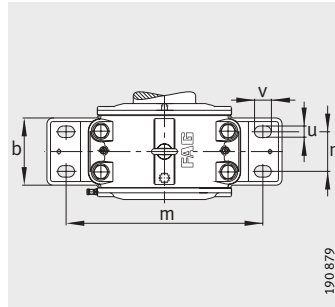

Dimension table (continued) · Dimensions in mm				Oil quantity	Oil level	Mass
Designation				Initial filling	Height x mm	m Housing ≈kg
Housing	Bearing	Adapter sleeve				
Locating bearings	Non-locating bearings			l		
LOE530-N-AF-L	LOE530-N-AL-L	22230-E1-K	H3130	4,2	65– 90	125
LOE530-N-BF-L	LOE530-N-BL-L	22230-E1-K	H3130	4,2	65– 90	125
LOE630-N-AF-L	LOE630-N-AL-L	22330-E1-K	H2330	6,2	75–110	200
LOE630-N-BF-L	LOE630-N-BL-L	22330-E1-K	H2330	6,2	75–110	200
LOE532-N-AF-L	LOE532-N-AL-L	22232-E1-K	H3132	4,7	60– 80	135
LOE532-N-BF-L	LOE532-N-BL-L	22232-E1-K	H3132	4,7	60– 80	135
LOE632-N-AF-L	LOE632-N-AL-L	22332-K-MB	H2332	7	80–105	240
LOE632-N-BF-L	LOE632-N-BL-L	22332-K-MB	H2332	7	80–105	240
LOE534-N-AF-L	LOE534-N-AL-L	22234-E1-K	H3134	6	90–105	160
LOE534-N-BF-L	LOE534-N-BL-L	22234-E1-K	H3134	6	80–105	160
LOE634-N-AF-L	LOE634-N-AL-L	22334-K-MB	H2334	7,2	80–105	270
LOE634-N-BF-L	LOE634-N-BL-L	22334-K-MB	H2334	7,2	80–105	270
LOE536-N-AF-L	LOE536-N-AL-L	22236-E1-K	H3136	6	75–110	200
LOE536-N-BF-L	LOE536-N-BL-L	22236-E1-K	H3136	6	75–110	200
LOE636-N-AF-L	LOE636-N-AL-L	22336-K-MB	H2336	7,4	80–105	330
LOE636-N-BF-L	LOE636-N-BL-L	22336-K-MB	H2336	7,4	80–105	330
LOE538-N-AF-L	LOE538-N-AL-L	22238-K-MB	H3138	7,2	70–100	230
LOE538-N-BF-L	LOE538-N-BL-L	22238-K-MB	H3138	7,2	70–100	230
LOE540-N-AF-L	LOE540-N-AL-L	22240-B-K-MB	H3140	7,2	75–100	250
LOE540-N-BF-L	LOE540-N-BL-L	22240-B-K-MB	H3140	7,2	75–100	250
LOE544-N-AF-L	LOE544-N-AL-L	22244-B-K-MB	H3144X	8,2	80–110	310
LOE544-N-BF-L	LOE544-N-BL-L	22244-B-K-MB	H3144X	8,2	80–110	310
LOE548-N-AF-L	LOE548-N-AL-L	22248-B-K-MB	H3148X	8,4	100–120	385
LOE548-N-BF-L	LOE548-N-BL-L	22248-B-K-MB	H3148X	8,4	100–120	385

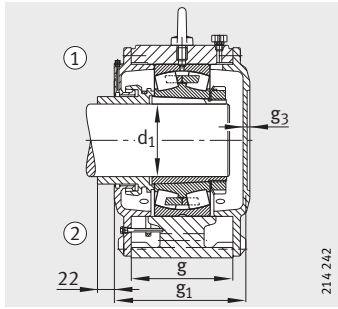

Design A
 ① Locating bearing AF
 ② Non-locating bearing AL

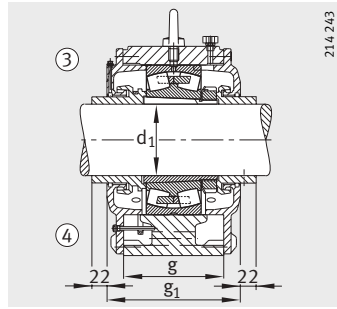

Design B
 ③ Locating bearing BF
 ④ Non-locating bearing BL

Dimensions

d_1	a	g_1	h_1	b	c	g	g_3	h	m	n	u	v	s
135	660	275	395	190	70	200	18	220	530	100	42	60	M36
135	660	275	395	190	70	200	—	220	530	100	42	60	M36
135	760	335	465	200	85	240	18	265	630	125	42	60	M36
135	760	335	465	200	85	240	—	265	630	125	42	60	M36
140	660	290	400	200	70	210	20	220	530	110	42	60	M36
140	660	290	400	200	70	210	—	220	530	110	42	60	M36
140	820	350	485	240	90	250	20	270	670	130	48	70	M42
140	820	350	485	240	90	250	—	270	670	130	48	70	M42
150	710	300	460	200	85	210	18	260	580	110	42	60	M36
150	710	300	460	200	85	210	—	260	580	110	42	60	M36
150	830	350	510	240	90	255	18	280	670	130	48	70	M42
150	830	350	510	240	90	255	—	280	670	130	48	70	M42
160	710	300	465	200	85	210	20	260	580	110	42	60	M36
160	710	300	465	200	85	210	—	260	580	110	42	60	M36
160	840	360	530	240	90	260	20	290	680	130	48	70	M42
160	840	360	530	240	90	260	—	290	680	130	48	70	M42
170	820	350	485	240	90	250	20	270	670	130	48	70	M42
170	820	350	485	240	90	250	—	270	670	130	48	70	M42
180	830	344	510	240	90	260	20	280	670	130	48	70	M42
180	830	344	510	240	90	260	—	280	670	130	48	70	M42
200	880	380	565	240	105	280	20	310	720	130	48	70	M42
200	880	380	565	240	105	280	—	310	720	130	48	70	M42
220	980	400	625	280	120	300	20	340	820	165	48	70	M42
220	980	400	625	280	120	300	—	340	820	165	48	70	M42



Plummer block housing units

VRE3, unsplit
With bearings and shaft

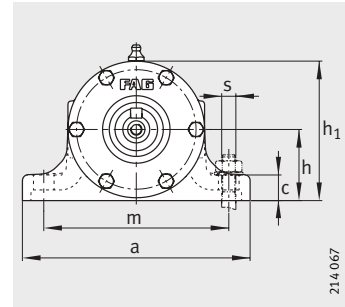

Cross-sections of designs C, D, page 1295, designs E, F, page 1297

Dimension table · Dimensions in mm									
Designation					Mass m		Dimensions		
Bearing unit	Bearing ①	Bearing ②	Housing	Shaft Complete	Housing ≈kg	Unit ≈kg	d	D	B
VRE305-A	6305-C3	6305-C3	VR305-A	VRW305-A	5	7	25	62	17
VRE305-B	NJ305-E-TVP2	6305-C3	VR305-A	VRW305-A	5	7	25	62	17
VRE305-C	NU305-E-TVP2-C3	2X7305-B-TVP-UA	VR305-C	VRW305-C	5,2	7,4	25	62	17
VRE305-D	NU305-E-TVP2-C3	6305-C3	VR305-D	VRW305-D	5,2	7,2	25	62	17
VRE305-E	NU305-E-TVP2-C3	NU305-E-TVP2-C3 + 6305-C3	VR305-E	VRW305-C	5,2	7,5	25	62	17
VRE305-F	6305-C3	6305-C3	VR305-F	VRW305-F	5	7	25	62	17
VRE306-A	6306-C3	6306-C3	VR306-A	VRW306-A	5,8	9	30	72	19
VRE306-B	NJ306-E-TVP2	6306-C3	VR306-A	VRW306-A	5,8	9	30	72	19
VRE306-C	NU306-E-TVP2-C3	2X7306-B-TVP-UA	VR306-C	VRW306-C	6	9,4	30	72	19
VRE306-D	NU306-E-TVP2-C3	6306-C3	VR306-D	VRW306-D	6	9,2	30	72	19
VRE306-E	NU306-E-TVP2-C3	NU306-E-TVP2-C3 + 6306-C3	VR306-E	VRW306-C	6	9,4	30	72	19
VRE306-F	6306-C3	6306-C3	VR306-F	VRW306-F	5,8	9	30	72	19
VRE307-A	6307-C3	6307-C3	VR307-A	VRW307-A	8,5	13	35	80	21
VRE307-B	NJ307-E-TVP2	6307-C3	VR307-A	VRW307-A	8,5	13	35	80	21
VRE307-C	NU307-E-TVP2-C3	2X7307-B-TVP-UA	VR307-C	VRW307-C	8,8	13,6	35	80	21
VRE307-D	NU307-E-TVP2-C3	6307-C3	VR307-D	VRW307-D	8,8	13,3	35	80	21
VRE307-E	NU307-E-TVP2-C3	NU307-E-TVP2-C3 + 6307-C3	VR307-E	VRW307-C	8,8	13,6	35	80	21
VRE307-F	6307-C3	6307-C3	VR307-F	VRW307-F	8,5	13	35	80	21
VRE308-A	6308-C3	6308-C3	VR308-A	VRW308-A	10,9	18	40	90	23
VRE308-B	NJ308-E-TVP2	6308-C3	VR308-A	VRW308-A	10,9	18	40	90	23
VRE308-C	NU308-E-TVP2-C3	2X7308-B-TVP-UA	VR308-C	VRW308-C	11,7	19,1	40	90	23
VRE308-D	NU308-E-TVP2-C3	6308-C3	VR308-D	VRW308-D	11,7	18,8	40	90	23
VRE308-E	NU308-E-TVP2-C3	NU308-E-TVP2-C3 + 6308-C3	VR308-E	VRW308-C	11,7	19,2	40	90	23
VRE308-F	6308-C3	6308-C3	VR308-F	VRW308-F	10,9	18	40	90	23
VRE309-A	6309-C3	6309-C3	VR309-A	VRW309-A	14,9	24,3	45	100	25
VRE309-B	NJ309-E-TVP2	6309-C3	VR309-A	VRW309-A	14,9	24,4	45	100	25
VRE309-C	NU309-E-TVP2-C3	2X7309-B-TVP-UA	VR309-C	VRW309-C	15,3	25,3	45	100	25
VRE309-D	NU309-E-TVP2-C3	6309-C3	VR309-D	VRW309-D	15,3	24,8	45	100	25
VRE309-E	NU309-E-TVP2-C3	NU309-E-TVP2-C3 + 6309-C3	VR309-E	VRW309-C	15,3	25,3	45	100	25
VRE309-F	6309-C3	6309-C3	VR309-F	VRW309-F	14,9	24,2	45	100	25

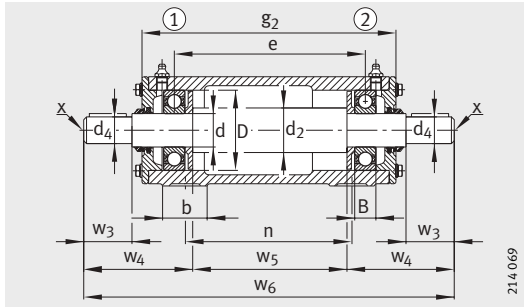

VRE3..-A

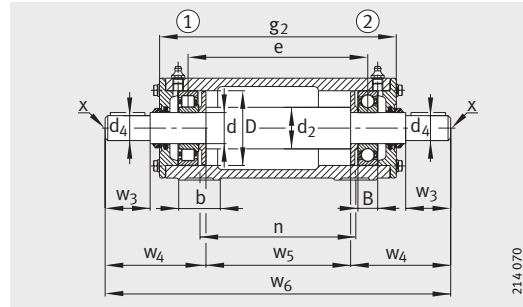

VRE..-B

a	g ₂	h ₁	d ₂	d ₄	w ₂	w ₃	w ₄	w ₅	w ₆	w ₇	e	b	n	m	c	h	s
155	198	87	35	19	-	40	90,5	117	298	-	148	35	135	120	16	45	M12
155	198	87	35	19	-	40	90,5	117	298	-	149	35	135	120	16	45	M12
155	198	87	35	19	40	42	90	101	298	107	140,5	35	135	120	16	45	M12
155	198	87	35	19	40	42	90	118	298	-	149	35	135	120	16	45	M12
155	198	87	35	19	40	42	90	101	298	107	132	35	135	120	16	45	M12
155	198	87	35	19	-	40	91,25	116,25	298	90,5	147,25	35	135	120	16	45	M12
160	225	98	40	24	-	50	102,5	140	345	-	173	40	150	130	18	50	M12
160	225	98	40	24	-	50	102,5	140	345	-	174	40	150	130	18	50	M12
160	225	98	40	24	50	52	104	122	349	123	164,5	40	150	130	18	50	M12
160	225	98	40	24	50	52	104	141	349	-	174	40	150	130	18	50	M12
160	225	98	40	24	50	52	104	122	349	123	155	40	150	130	18	50	M12
160	225	98	40	24	-	50	103,25	139,25	345	102,5	172,25	40	150	130	18	50	M12
190	255	113	45	28	-	60	117,5	160	395	-	197	45	175	150	18	60	M12
190	255	113	45	28	-	60	117,5	160	395	-	198	45	175	150	18	60	M12
190	255	113	45	28	60	62	119	140	399	140	187,5	45	175	150	18	60	M12
190	255	113	45	28	60	62	119	161	399	-	198	45	175	150	18	60	M12
190	255	113	45	28	60	62	119	140	399	140	177	45	175	150	18	60	M12
190	255	113	45	28	-	60	118,5	159	395	117,5	196	45	175	150	18	60	M12
190	317	118	50	32	-	80	143,5	214	501	-	257	52	225	150	20	60	M12
190	317	118	50	32	-	80	143,5	214	501	-	258	52	225	150	20	60	M12
190	317	118	50	32	80	82	143	192	501	166	246,5	52	225	150	20	60	M12
190	317	118	50	32	80	82	143	215	501	-	258	52	225	150	20	60	M12
190	317	118	50	32	80	82	143	192	501	166	235	52	225	150	20	60	M12
190	317	118	50	32	-	80	144,5	213	501	143,5	256	52	225	150	20	60	M12
210	343	135	55	38	-	80	145,5	236	527	-	281	52	250	170	22	70	M12
210	343	135	55	38	-	80	145,5	236	527	-	282	52	250	170	22	70	M12
210	343	135	55	38	80	82	145	212	527	170	269,5	52	250	170	22	70	M12
210	343	135	55	38	80	82	145	237	527	-	282	52	250	170	22	70	M12
210	343	135	55	38	80	82	145	212	527	170	257	52	250	170	22	70	M12
210	343	135	55	38	-	80	146,5	235	527	145,5	280	52	250	170	22	70	M12



Plummer block housing units

VRE3, unsplit
With bearings and shaft

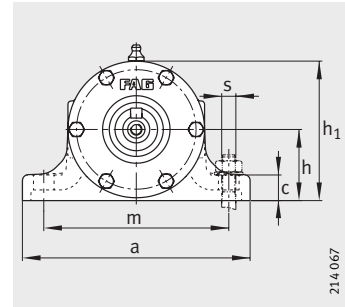

Cross-sections of designs A, B, page 1293, designs E, F, page 1297

Dimension table (continued) · Dimensions in mm									
Designation					Mass m		Dimensions		
Bearing unit	Bearing ①	Bearing ②	Housing	Shaft Complete	Housing ≈kg	Unit ≈kg	d	D	B
VRE310-A	6310-C3	6310-C3	VR310-A	VRW310-A	17,3	30,3	50	110	27
VRE310-B	NJ310-E-TVP2	6310-C3	VR310-A	VRW310-A	17,3	30,3	50	110	27
VRE310-C	NU310-E-TVP2-C3	2X7310-B-TVP-UA	VR310-C	VRW310-C	17,9	31,7	50	110	27
VRE310-D	NU310E-TVP2-C3	6310-C3	VR310-D	VRW310-D	17,9	30,9	50	110	27
VRE310-E	NU310-E-TVP2-C3	NU310-E-TVP2-C3 + 6310-C3	VR310-E	VRW310-C	17,9	31,8	50	110	27
VRE310-F	6310-C3	6310-C3	VR310-F	VRW310-F	17,3	30,3	50	110	27
VRE311-A	6311-C3	6311-C3	VR311-A	VRW311-A	22	38,6	55	120	29
VRE311-B	NJ311-E-TVP2	6311-C3	VR311-A	VRW311-A	22	38,7	55	120	29
VRE311-C	NU311-E-TVP2-C3	2X7311-B-TVP-UA	VR311-C	VRW311-C	22,5	40,2	55	120	29
VRE311-D	NU311-E-TVP2-C3	6311-C3	VR311-D	VRW311-D	22,5	39,2	55	120	29
VRE311-E	NU311-E-TVP2-C3	NU311-E-TVP2-C3 + 6311-C3	VR311-E	VRW311-C	22,5	40,2	55	120	29
VRE311-F	6311-C3	6311-C3	VR311-F	VRW311-F	22	38,6	55	120	29
VRE312-A	6312-C3	6312-C3	VR312-A	VRW312-A	30,7	51,2	60	130	31
VRE312-B	NJ312-E-TVP2	6312-C3	VR312-A	VRW312-A	30,7	51,4	60	130	31
VRE312-C	NU312-E-TVP2-C3	2X7312-B-TVP-UA	VR312-C	VRW312-C	31,7	53,8	60	130	31
VRE312-D	NU312-E-TVP2-C3	6312-C3	VR312-D	VRW312-D	31,7	52,4	60	130	31
VRE312-E	NU312-E-TVP2-C3	NU312-E-TVP2-C3 + 6312-C3	VR312-E	VRW312-C	31,7	53,7	60	130	31
VRE312-F	6312-C3	6312-C3	VR312-F	VRW312-F	30,7	51,1	60	130	31
VRE313-A	6313-C3	6313-C3	VR313-A	VRW313-A	32,8	58	65	140	33
VRE313-B	NJ313-E-TVP2	6313-C3	VR313-A	VRW313-A	32,8	58,2	65	140	33
VRE313-C	NU313-E-TVP2-C3	2X7313-B-TVP-UA	VR313-C	VRW313-C	33,8	60,8	65	140	33
VRE313-D	NU313-E-TVP2-C3	6313-C3	VR313-D	VRW313-D	33,8	59,3	65	140	33
VRE313-E	NU313-E-TVP2-C3	NU313-E-TVP2-C3 + 6313-C3	VR313-E	VRW313-C	33,8	60,8	65	140	33
VRE313-F	6313-C3	6313-C3	VR313-F	VRW313-F	32,8	58	65	140	33
VRE314-A	6314-C3	6314-C3	VR314-A	VRW314-A	35	66,9	70	150	35
VRE314-B	NJ314-E-TVP2	6314-C3	VR314-A	VRW314-A	35	67,1	70	150	35
VRE314-C	NU314-E-TVP2-C3	2X7314-B-TVP-UA	VR314-C	VRW314-C	36	70,4	70	150	35
VRE314-D	NU314-E-TVP2-C3	6314-C3	VR314-D	VRW314-D	36	68	70	150	35
VRE314-E	NU314-E-TVP2-C3	NU314-E-TVP2-C3 + 6314-C3	VR314-E	VRW314-C	36	70,6	70	150	35
VRE314-F	6314-C3	6314-C3	VR314-F	VRW314-F	35	66,8	70	150	35

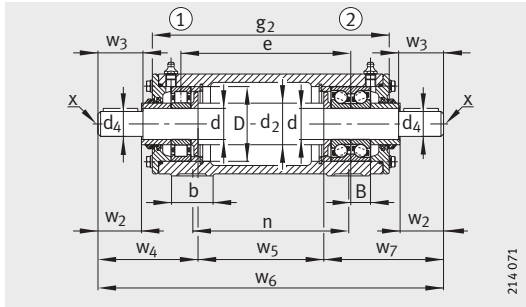

VRE3..-C

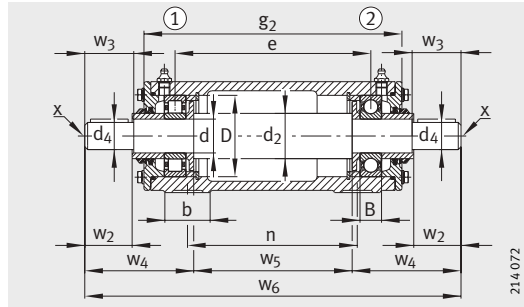

VRE3..-D

a	g ₂	h ₁	d ₂	d ₄	w ₂	w ₃	w ₄	w ₅	w ₆	w ₇	e	b	n	m	c	h	s
210	381	138	60	42	-	110	179,5	266	625	-	313	60	275	170	25	70	M12
210	381	138	60	42	-	110	179,5	266	625	-	314	60	275	170	25	70	M12
210	381	138	60	42	110	112	179	240	625	206	300,5	60	275	170	25	70	M12
210	381	138	60	42	110	112	179	267	625	-	314	60	275	170	25	70	M12
210	381	138	60	42	110	112	179	240	625	206	287	60	275	170	25	70	M12
210	381	138	60	42	-	110	180,5	265	625	179,5	312	60	275	170	25	70	M12
260	407	158	65	48	-	110	181,5	288	651	-	337	60	300	210	25	80	M16
260	407	158	65	48	-	110	181,5	288	651	-	338	60	300	210	25	80	M16
260	407	158	65	48	110	112	181	260	651	210	323,5	60	300	210	25	80	M16
260	407	158	65	48	110	112	181	289	651	-	338	60	300	210	25	80	M16
260	407	158	65	48	110	112	181	260	651	210	309	60	300	210	25	80	M16
260	407	158	65	48	-	110	182,5	287	651	181,5	336	60	300	210	25	80	M16
260	457	162	70	48	-	110	183,5	334	701	-	385	70	340	210	25	80	M16
260	457	162	70	48	-	110	183,5	334	701	-	386	70	340	210	25	80	M16
260	457	162	70	48	110	112	185,5	304	706	216,5	370,5	70	340	210	25	80	M16
260	457	162	70	48	110	112	185,5	335	706	-	386	70	340	210	25	80	M16
260	457	162	70	48	110	112	185,5	304	706	216,5	355	70	340	210	25	80	M16
260	457	162	70	48	-	110	184,5	333	701	183,5	384	70	340	210	25	80	M16
290	480	183	75	55	-	110	187,5	349	724	-	404	70	360	230	25	95	M16
290	480	183	75	55	-	110	187,5	349	724	-	405	70	360	230	25	95	M16
290	480	183	75	55	110	112	189,5	317	729	222,5	388,5	70	360	230	25	95	M16
290	480	183	75	55	110	112	189,5	350	729	-	405	70	360	230	25	95	M16
290	480	183	75	55	110	112	189,5	317	729	222,5	372	70	360	230	25	95	M16
290	480	183	75	55	-	110	189	347,5	724	187,5	402,5	70	360	230	25	95	M16
290	500	188	80	60	-	140	223	365	811	-	422	70	380	230	25	95	M16
290	500	188	80	60	-	140	223	365	811	-	423	70	380	230	25	95	M16
290	500	188	80	60	140	143	222,5	331	811	257,5	405,5	70	380	230	25	95	M16
290	500	188	80	60	140	143	222,5	366	811	-	423	70	380	230	25	95	M16
290	500	188	80	60	140	143	222,5	331	811	257,5	388	70	380	230	25	95	M16
290	500	188	80	60	-	140	224,5	363,5	811	223	420,5	70	380	230	25	95	M16



Plummer block housing units

VRE3, unsplit
With bearings and shaft

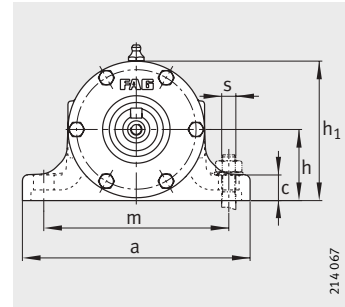

Cross-sections of
designs A, B, page 1293,
designs C, D, page 1295

Dimension table (continued) · Dimensions in mm									
Designation					Mass m		Dimensions		
Bearing unit	Bearing ①	Bearing ②	Housing	Shaft Complete	Housing ≈kg	Unit ≈kg	d	D	B
VRE315-A	6315-C3	6315-C3	VR315-A	VRW315-A	44,8	84,8	75	160	37
VRE315-B	NJ315-E-TVP2	6315-C3	VR315-A	VRW315-A	44,8	85	75	160	37
VRE315-C	NU315-E-TVP2-C3	2X7315-B-TVP-UA	VR315-C	VRW315-C	46,4	89,3	75	160	37
VRE315-D	NU315-E-TVP2-C3	6315-C3	VR315-D	VRW315-D	46,4	86,4	75	160	37
VRE315-E	NU315-E-TVP2-C3	NU315-E-TVP2-C3 + 6315-C3	VR315-E	VRW315-C	46,4	89,4	75	160	37
VRE315-F	6315-C3	6315-C3	VR315-F	VRW315-F	44,8	84,8	75	160	37
VRE316-A	6316-C3	6316-C3	VR316-A	VRW316-A	44	90,8	80	170	39
VRE316-B	NJ316-E-TVP2	6316-C3	VR316-A	VRW316-A	44	91	80	170	39
VRE316-C	NU316-E-TVP2-C3	2X7316-B-TVP-UA	VR316-C	VRW316-C	45	96,2	80	170	39
VRE316-D	NU316-E-TVP2-C3	6316-C3	VR316-D	VRW316-D	45	91,9	80	170	39
VRE316-E	NU316-E-TVP2-C3	NU316-E-TVP2-C3 + 6316-C3	VR316-E	VRW316-C	45	95,3	80	170	39
VRE316-F	6316-C3	6316-C3	VR316-F	VRW316-F	44	90,8	80	170	39
VRE317-A	6317-C3	6317-C3	VR317-A	VRW317-A	59,2	114	85	180	41
VRE317-B	NJ317-E-TVP2	6317-C3	VR317-A	VRW317-A	59,2	115	85	180	41
VRE317-C	NU317-E-TVP2-C3	2X7317-B-TVP-UA	VR317-C	VRW317-C	60	120	85	180	41
VRE317-D	NU317-E-TVP2-C3	6317-C3	VR317-D	VRW317-D	60	115	85	180	41
VRE317-E	NU317-E-TVP2-C3	NU317-E-TVP2-C3 + 6317-C3	VR317-E	VRW317-C	60	120	85	180	41
VRE318-A	6318-C3	6318-C3	VR318-A	VRW318-A	62	128	90	190	43
VRE318-B	NJ318-E-TVP2	6318-C3	VR318-A	VRW318-A	62	128	90	190	43
VRE318-C	NU318-E-TVP2-C3	2X7318-B-TVP-UA	VR318-C	VRW318-C	63	134	90	190	43
VRE318-D	NU318-E-TVP2-C3	6318-C3	VR318-D	VRW318-D	63	129	90	190	43
VRE318-E	NU318-E-TVP2-C3	NU318-E-TVP2-C3 + 6318-C3	VR318-E	VRW318-C	63	134	90	190	43
VRE319-A	6319-C3	6319-C3	VR319-A	VRW319-A	84,1	156	95	200	45
VRE319-B	NJ319-E-TVP2	6319-C3	VR319-A	VRW319-A	84,1	157	95	200	45
VRE319-C	NU319-E-TVP2-C3	2X7319-B-TVP-UA	VR319-C	VRW319-C	86	164	95	200	45
VRE319-D	NU319-E-TVP2-C3	6319-C3	VR319-D	VRW319-D	86	158	95	200	45
VRE319-E	NU319-E-TVP2-C3	NU319-E-TVP2-C3 + 6319-C3	VR319-E	VRW319-C	86	164	95	200	45
VRE320-A	6320-C3	6320-C3	VR320-A	VRW320-A	90	177	100	215	47
VRE320-B	NJ320-E-TVP2	6320-C3	VR320-A	VRW320-A	90	177	100	215	47
VRE320-C	NU320-E-TVP2-C3	2X7320-B-TVP-UA	VR320-C	VRW320-C	92	186	100	215	47
VRE320-D	NU320-E-TVP2-C3	6320-C3	VR320-D	VRW320-D	92	179	100	215	47
VRE320-E	NU320-E-TVP2-C3	NU320-E-TVP2-C3 + 6320-C3	VR320-E	VRW320-C	92	186	100	215	47

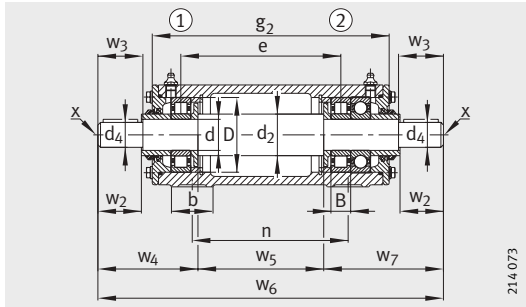

VRE3..-E

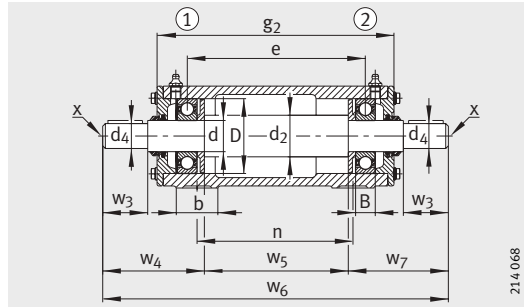

VRE3..-F

a	g ₂	h ₁	d ₂	d ₄	w ₂	w ₃	w ₄	w ₅	w ₆	w ₇	e	b	n	m	c	h	s
320	530	198	90	65	-	140	226	389	841	-	450	80	400	260	30	100	M16
320	530	198	90	65	-	140	226	389	841	-	451	80	400	260	30	100	M16
320	530	198	90	65	140	143	225,5	353	841	262,5	432,5	80	400	260	30	100	M16
320	530	198	90	65	140	143	225,5	390	841	-	451	80	400	260	30	100	M16
320	530	198	90	65	140	143	225,5	353	841	262,5	414	80	400	260	30	100	M16
320	530	198	90	65	-	140	227,5	387,5	841	226	448,5	80	400	260	30	100	M16
320	550	217	95	70	-	140	228	405	861	-	468	80	420	260	30	112	M16
320	550	217	95	70	-	140	228	405	861	-	469	80	420	260	30	112	M16
320	550	217	95	70	140	143	227,5	367	861	266,5	449,5	80	420	260	30	112	M16
320	550	217	95	70	140	143	227,5	406	861	-	469	80	420	260	30	112	M16
320	550	217	95	70	140	143	227,5	367	861	266,5	430	80	420	260	30	112	M16
320	550	217	95	70	-	140	229,5	403,5	861	228	466,5	80	420	260	30	112	M16
350	570	222	100	75	-	140	230	421	881	-	486	80	440	290	30	112	M16
350	570	222	100	75	-	140	230	421	881	-	487	80	440	290	30	112	M16
350	570	222	100	75	140	143	229,5	381	881	270,5	466,5	80	440	290	30	112	M16
350	570	222	100	75	140	143	229,5	422	881	-	487	80	440	290	30	112	M16
350	570	222	100	75	140	143	229,5	381	881	270,5	446	80	440	290	30	112	M16
350	600	227	105	80	-	170	263	445	971	-	510	85	460	290	30	112	M16
350	600	227	105	80	-	170	263	445	971	-	511	85	460	290	30	112	M16
350	600	227	105	80	170	173	264,5	403	975	307,5	489,5	85	460	290	30	112	M16
350	600	227	105	80	170	173	264,5	446	975	-	511	85	460	290	30	112	M16
350	600	227	105	80	170	173	264,5	403	975	307,5	468	85	460	290	30	112	M16
400	633	248	110	85	-	170	267,5	469	1004	-	540	90	480	320	35	125	M20
400	633	248	110	85	-	170	267,5	469	1004	-	541	90	480	320	35	125	M20
400	633	248	110	85	170	173	269	425	1008	314	518,5	90	480	320	35	125	M20
400	633	248	110	85	170	173	269	470	1008	-	541	90	480	320	35	125	M20
400	633	248	110	85	170	173	269	425	1008	314	496	90	480	320	35	125	M20
400	665	260	120	90	-	170	268	500	1036	-	570	95	500	320	40	130	M20
400	665	260	120	90	-	170	268	500	1036	-	571	95	500	320	40	130	M20
400	665	260	120	90	170	173	269,5	454	1040	316,5	547,5	95	500	320	40	130	M20
400	665	260	120	90	170	173	269,5	501	1040	-	571	95	500	320	40	130	M20
400	665	260	120	90	170	173	269,5	454	1040	316,5	524	95	500	320	40	130	M20



Plummer block housing units

VRE3, unsplit
With bearings and shaft

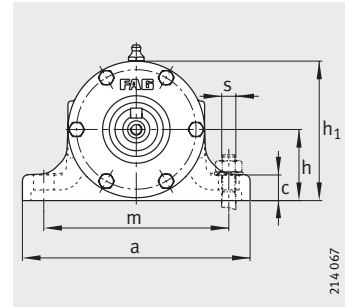

Cross-sections of designs C, D, page 1295, design E, page 1297

Dimension table (continued) · Dimensions in mm									
Designation					Mass m		Dimensions		
Bearing unit	Bearing ①	Bearing ②	Housing	Shaft Complete	Housing ≈kg	Unit ≈kg	d	D	B
VRE322-A	6322-C3	6322-C3	VR322-A	VRW322-A	130	226	110	240	50
VRE322-B	NJ322-E-TVP2	6322-C3	VR322-A	VRW322-A	130	226	110	240	50
VRE322-C	NU322-E-TVP2-C3	2X7322-B-TVP-UA	VR322-C	VRW322-C	132	238	110	240	50
VRE322-D	NU322-E-TVP2-C3	6322-C3	VR322-D	VRW322-D	132	228	110	240	50
VRE322-E	NU322-E-TVP2-C3	NU322-E-TVP2-C3 + 6322-C3	VR322-E	VRW322-C	132	238	110	240	50
VRE324-A	6324-C3	6324-C3	VR324-A	VRW324-A	170	276	120	260	55
VRE324-B	NJ324-E-TVP2	6324-C3	VR324-A	VRW324-A	170	277	120	260	55
VRE324-C	NU324-E-TVP2-C3	2X7324-B-TVP-UA	VR324-C	VRW324-C	172	294	120	260	55
VRE324-D	NU324-E-TVP2-C3	6324-C3	VR324-D	VRW324-D	172	278	120	260	55
VRE324-E	NU324-E-TVP2-C3	NU324-E-TVP2-C3 + 6324-C3	VR324-E	VRW324-C	172	291	120	260	55

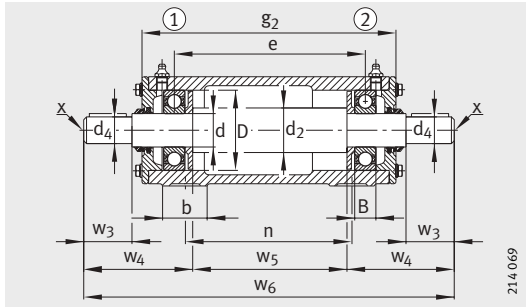

VRE3..-A

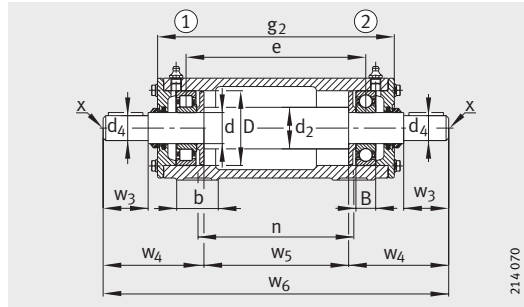

VRE3..-B

a	g ₂	h ₁	d ₂	d ₄	w ₂	w ₃	w ₄	w ₅	w ₆	w ₇	e	b	n	m	c	h	s
450	678	295	130	100	–	210	313	507	1 133	–	580	95	520	380	40	150	M24
450	678	295	130	100	–	210	313	507	1 133	–	581	95	520	380	40	150	M24
450	678	295	130	100	210	213	312,5	458	1 133	362,5	556	95	520	380	40	150	M24
450	678	295	130	100	210	213	312,5	508	1 133	–	581	95	520	380	40	150	M24
450	678	295	130	100	210	213	312,5	458	1 133	362,5	531	95	520	380	40	150	M24
500	705	320	140	110	–	210	318	524	1 160	–	602	100	540	410	40	160	M24
500	705	320	140	110	–	210	318	524	1 160	–	603	100	540	410	40	160	M24
500	705	320	140	110	210	213	317,5	470	1 160	372,5	575,5	100	540	410	40	160	M24
500	705	320	140	110	210	213	317,5	525	1 160	–	603	100	540	410	40	160	M24
500	705	320	140	110	210	213	317,5	470	1 160	372,5	548	100	540	410	40	160	M24



Plummer block housings

BND, unsplit
For spherical roller bearings

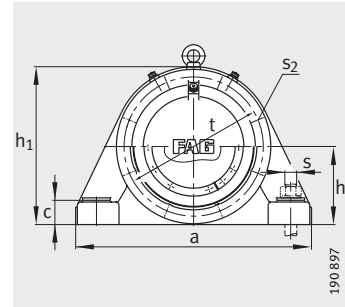
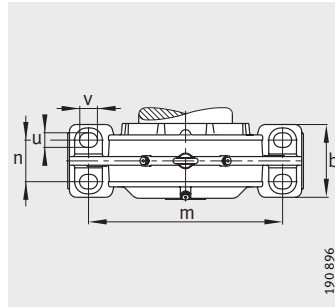

Cross-section of BND housings for bearings with tapered bore: see page 1303 to page 1305

Dimension table · Dimensions in mm												
Designation ¹⁾			Mass m Housing ≈ kg	Dimensions								
Housing	Bearing	Adapter sleeve		d	d ₁	a	g ₁	h ₁	b	c	d _c min.	d _z min.
BND2213	22213-	H313	23	65	60	235	100	155	70	22	66	71
BND2215	22215-	H315	15	75	65	285	105	180	85	35	71	81
BND2218	22218-	H318	28	90	80	370	104	220	110	38	88	98
BND2220	22220-	H320	30	100	90	400	141	255	120	40	98	108
BND2222	22222-	H322	50	110	100	440	149,2	280	130	42	108	118
BND3122	23122-	H3122	40	110	100	400	146	263	140	40	108	118
BND3222	23222-	H2322	35	110	100	440	166	280	130	42	108	118
BND2224	22224-	H3124	58	120	110	470	143	300	140	42	118	128
BND3024	23024-	H3024	20	120	110	370	126	230	110	35	118	128
BND3124	23124-	H3124	50	120	110	410	160	280	150	40	118	128
BND3224	23224-	H2324	40	120	110	470	161	300	140	42	118	128
BND2226	22226-	H3126	65	130	115	500	172	315	150	45	127	142
BND3026	23026-	H3026	30	130	115	410	133	260	120	38	123	138
BND3126	23126-	H3126	55	130	115	430	165	295	150	40	123	138
BND3226	23226-	H2326	50	130	115	500	188	315	150	45	127	142
BND2228	22228-	H3128	70	140	125	530	166	345	160	50	137	152
BND3028	23028-	H3028	35	140	125	430	136	275	130	40	133	148
BND3128	23128-	H3128	60	140	125	470	170	315	160	45	133	148
BND3228	23228-	H2328	65	140	125	530	186	345	160	50	137	152
BND2230	22230-	H3130	85	150	135	550	177	365	170	54	147	162
BND3030	23030-	H3030	40	150	135	455	149	290	140	42	143	158
BND3130	23130-	H3130	70	150	135	580	186	345	200	60	143	158
BND3230	23230-	H2330	75	150	135	550	200	365	170	54	147	162
BND2232	22232-	H3132	100	160	140	600	189	385	180	58	152	172
BND3032	23032-	H3032	45	160	140	480	156	310	150	45	148	168
BND3132	23132-	H3132	80	160	140	540	200	360	200	55	148	168
BND3232	23232-	H2332	90	160	140	600	213	385	180	58	152	172
BND2234	22234-	H3134	105	170	150	640	216	405	200	62	166	186
BND3034	23034-	H3034	70	170	150	510	166	330	160	50	158	178
BND3134	23134-	H3134	100	170	150	570	215	380	200	55	158	178
BND3234	23234-	H2334	120	170	150	640	240	405	200	62	166	186

¹⁾ Ordering example:
Housing BND3030-Z-Y-BL-S (see also page 1207), bearing 23030-E1-TVPB (see bearing tables).

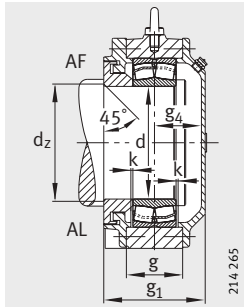

Design A
Housing with labyrinth seal
for bearings with cylindrical bore

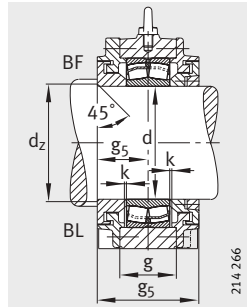

Design B

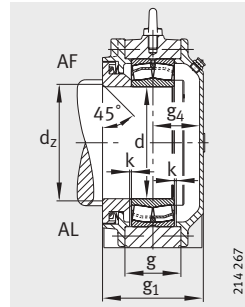

Design A
Housing with Taconite seal
for bearings with cylindrical bore

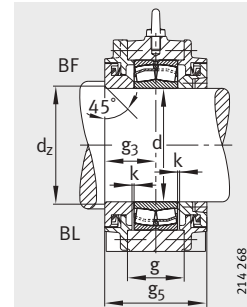

Design B

g	g ₂	g ₃	g ₄ min.	g ₅	h	k	m	n	u	v	s	t	s ₂	s ₂ Quantity
44	120	55	39	110	80	2	185	40	15	20	M10	135	M 6	6
45	125	55	44	110	90	2	225	45	20	28	M16	155	M 6	6
55	123	53	45	106	110	2	290	60	23	32	M20	185	M 8	6
65	168	78	57	156	130	2,5	320	65	30	35	M24	205	M 8	6
73	172	82,6	60	165,2	140	2,5	350	70	30	35	M24	230	M12	6
80	171	78	62	156	130	2,5	300	80	25	35	M20	215	M12	8
89,8	194	91	68	182	140	2,5	350	70	30	35	M24	230	M12	6
77	168	74	61	148	150	2,5	370	75	30	35	M24	245	M12	6
60	146	63	57	126	115	2,5	300	60	25	35	M20	205	M 8	8
85	180	80	74	160	140	2,5	330	80	25	35	M20	235	M12	8
95	186	83	70	166	150	2,5	370	75	30	35	M24	245	M12	6
84	202	95	69	190	160	3	400	85	30	35	M24	260	M12	6
70	156	68	59	136	130	2	340	60	25	35	M20	225	M10	8
90	190	85	72	170	145	3	350	80	25	35	M20	245	M12	8
100	218	103	77	206	160	3	400	85	30	35	M24	260	M12	6
88	196	88	70	176	170	3	430	85	30	35	M24	285	M16	6
70	156	68	61	136	140	3	360	70	30	35	M24	240	M10	8
95	190	85	77	170	155	3	380	85	25	35	M20	270	M12	8
108	216	98	80	196	170	3	430	85	30	35	M24	285	M16	6
97	202	93,5	76	187	180	3	450	90	36	45	M30	305	M16	6
80	176	78	64	156	145	2	370	80	30	35	M24	250	M12	8
102	206	93	85	186	170	2	450	110	30	35	M24	285	M12	8
120	225	105	87	210	180	3	450	90	36	45	M30	305	M16	6
106	226	103	78	206	190	3	490	105	36	45	M30	330	M16	6
85	181	78	71	156	155	3	390	90	30	35	M24	265	M12	8
110	230	105	87	210	180	3	430	110	30	35	M24	310	M16	6
130	250	115	90	230	190	3	490	105	36	45	M30	330	M16	6
111	256	118	88	236	200	3	525	110	36	45	M30	350	M16	8
90	191	83	75	166	165	2	420	95	36	45	M30	285	M12	8
120	250	115	90	230	190	3	470	110	36	45	M30	330	M12	8
135	280	130	100	260	200	3	525	110	36	45	M30	350	M16	8



Plummer block housings

BND, unsplit
For spherical roller bearings

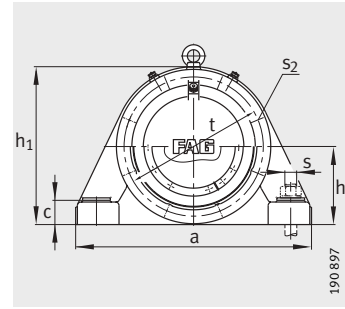
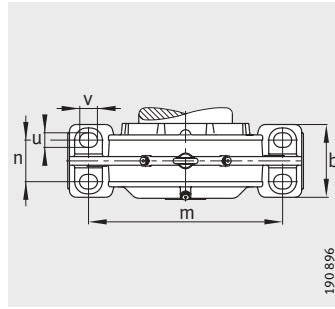

Cross-section of BND housings for bearings with cylindrical bore: see page 1301

Dimension table (continued) · Dimensions in mm												
Designation ¹⁾			Mass m Housing ≈ kg	Dimensions								
Housing	Bearing	Adapter sleeve		d	d ₁	a	g ₁	h ₁	b	c	d _c min.	d _z min.
BND2236	22236-	H3136	130	180	160	680	214	425	210	65	176	196
BND3036	23036-	H3036	70	180	160	540	176	360	170	52	168	188
BND3136	23136-	H3136	110	180	160	600	220	395	200	58	172	192
BND3236	23236-	H2336	140	180	160	680	240	425	210	65	176	196
BND2238	22238-	H3138	170	190	170	710	222	455	220	85	186	206
BND3038	23038-	H3038	80	190	170	570	181	370	180	55	178	198
BND3138	23138-	H3138	125	190	170	680	232	425	210	65	182	202
BND3238	23228-	H2338	170	190	170	710	250	455	220	85	186	206
BND2240	22240-	H3140	185	200	180	780	230	475	240	75	196	216
BND3040	23040-	H3040	95	200	180	600	196	400	190	60	188	208
BND3140	23140-	H3140	170	200	180	710	242	455	220	85	192	212
BND3240	23240-	H2340	205	200	180	780	260	475	240	75	196	216
BND2244	22244-	H3144X	290	220	200	890	264	550	250	80	216	236
BND3044	23044-	H3044X	100	220	200	640	206	430	200	65	212	232
BND3144	23144-	H3144X	190	220	200	780	252	475	240	75	216	236
BND3244	23244-	H2344X	240	220	200	850	279	525	250	80	216	236
BND2248	22248-	H3148X	315	240	220	900	268	585	250	90	236	256
BND3048	23048-	H3048	130	240	220	680	216	455	210	70	232	252
BND3148	23148-	H3148X	280	240	220	890	284	550	250	80	236	256
BND3248	23248-	H2348X	330	240	220	900	308	585	250	90	236	256
BND2252	22252-	H3152X	370	260	240	960	286	625	290	95	260	280
BND3052	23052-	H3052X	160	260	240	720	226	500	220	75	256	276
BND3152	23152-	H3152X	310	260	240	900	292	585	250	90	256	276
BND3252	23252-	H2352X	380	260	240	960	330	625	290	95	260	280
BND2256	22256-	H3156X	420	280	260	1 000	297	645	300	100	280	300
BND3056	23056-	H3056	180	280	260	760	236	520	240	80	276	296
BND3156	23156-	H3156X	335	280	260	900	294	585	250	90	280	300
BND3256	23256-	H2356X	490	280	260	1 000	343	645	300	100	280	300

¹⁾ Ordering example:
Housing BND3040-H-W-T-BL-S (see also page 1209), bearing 23040-E1-K-TVPB (see bearing tables), adapter sleeve H3040-HG (see dimension tables).

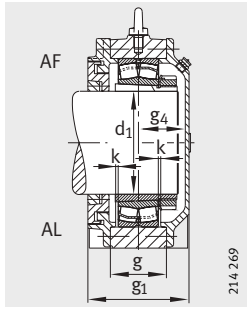

Design A
Housing with labyrinth seal
for bearings with tapered bore

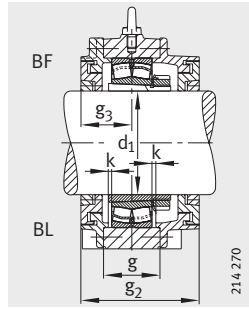

Design B

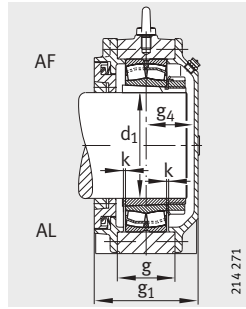

Design A
Housing with Taconite seal
for bearings with tapered bore

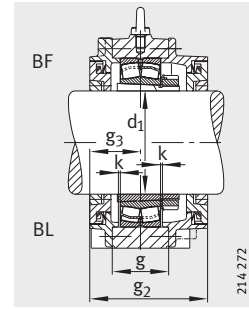

Design B

g	g ₂	g ₃	g ₄ min.	g ₅	h	k	m	n	u	v	s	t	s ₂	s ₂ Quantity
112	248	114	92	228	210	3	550	120	36	45	M30	370	M16	8
100	201	88	80	176	180	3	450	100	36	45	M30	310	M12	8
125	250	115	95	230	200	3	490	105	36	45	M30	350	M16	8
138	274	127	105	254	210	3	550	120	36	45	M30	370	M16	8
115	258	114	98	228	220	3	560	120	42	52	M36	380	M16	8
105	211	93	80	186	185	3	480	105	36	45	M30	325	M12	8
130	266	123	98	246	210	3	550	120	36	45	M30	370	M16	8
143	286	128	112	256	220	3	560	120	42	52	M36	380	M16	8
128	269	123	99	246	235	4	640	140	42	52	M36	420	M16	8
110	226	98	90	196	200	3	510	110	36	45	M30	340	M16	8
135	278	124	108	248	220	3	560	120	42	52	M36	380	M16	8
158	299	138	114	276	235	4	640	140	42	52	M36	420	M16	8
140	314	142	112	284	270	4	720	140	42	52	M36	455	M20	8
115	241	103	95	206	215	3	540	115	42	52	M36	375	M16	8
150	291	134	110	268	235	4	640	140	42	52	M36	420	M16	8
175	329	147	122	294	260	4	700	140	42	52	M36	445	M20	8
150	311	138	120	276	290	4	750	140	42	52	M36	510	M20	8
120	251	108	100	216	225	4	560	120	42	52	M36	400	M16	8
160	334	152	122	304	270	4	720	140	42	52	M36	455	M20	8
190	351	158	140	316	290	4	750	140	42	52	M36	510	M20	8
161	326	148	126	296	310	3	800	160	42	52	M36	535	M20	8
130	261	113	103	226	250	4	600	130	42	52	M36	440	M16	8
174	335	150	132	300	290	4	750	140	42	52	M36	510	M20	8
205	370	170	148	340	310	3	800	160	42	52	M36	535	M20	8
160	354	157	128	314	320	4	840	170	42	52	M36	555	M24	8
135	281	118	108	236	260	4	630	140	42	52	M36	460	M16	8
176	337	151	133	302	290	4	750	140	42	52	M36	510	M20	8
206	400	180	151	360	320	4	840	170	42	52	M36	555	M24	8



Plummer block housings

BND, unsplit
For spherical roller bearings

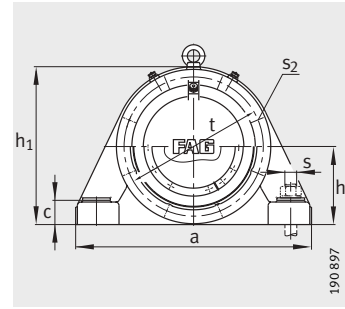
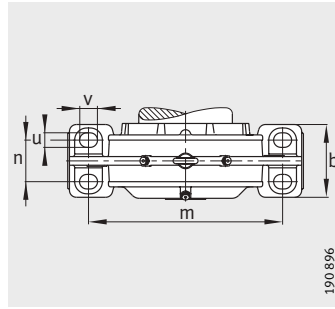

Cross-section of BND housings for bearings with cylindrical bore: see page 1301

Dimension table (continued) · Dimensions in mm												
Designation ¹⁾			Mass m Housing ≈ kg	Dimensions								
Housing	Bearing	Adapter sleeve		d	d ₁	a	g ₁	h ₁	b	c	d _c min.	d _z min.
BND2260	22260-	H3160	485	300	280	1 100	317	695	330	105	300	320
BND3060	23060-	H3060	220	300	280	820	261	570	250	85	296	316
BND3160	23160-	H3160	400	300	280	1 000	327	645	300	100	300	320
BND3260	23260-	H3260	570	300	280	1 100	369	705	330	105	300	320
BND2264	22264-	H3164	600	320	300	1 150	333	745	360	115	320	340
BND3064	23064-	H3064	250	320	300	860	266	590	260	90	316	336
BND3164	23164-	H3164	500	320	300	1 150	359	700	300	100	320	340
BND3264	23264-	H3264	665	320	300	1 150	391	745	360	115	320	340
BND2268	22268-	H3168	635	340	320	1 200	375	790	380	125	344	364
BND3068	23068-	H3068	300	340	320	900	276	630	270	95	340	360
BND3168	23168-	H3168	520	340	320	1 150	373	745	360	115	340	360
BND3268	23268-	H3268	755	340	320	1 200	434	790	380	125	344	364
BND2272	22272-	H3172	690	360	340	1 280	375	820	400	130	364	384
BND3072	23072-	H3072	330	360	340	960	290	660	280	100	360	380
BND3172	23172-	H3172	600	360	340	1 200	400	760	370	115	360	380
BND3272	23272-	H3272	950	360	340	1 280	437	820	400	130	364	384
BND2276	22276-	H3176	900	380	360	1 350	433	865	405	135	384	404
BND3076	23076-	H3076	360	380	360	1 000	294	680	300	105	380	400
BND3176	23176-	H3176	720	380	360	1 200	404	790	380	125	380	400
BND3276	23276-	H3276	1 100	380	360	1 350	489	860	405	135	384	404
BND2280	22280-	H3180	940	400	380	1 430	433	900	450	145	404	424
BND3080	23080-	H3080	400	400	380	1 060	310	720	320	110	400	420
BND3180	23180-	H3180	750	400	380	1 280	405	820	400	130	404	424
BND3280	23280-	H3280	1 205	400	380	1 430	504	900	450	145	404	424
BND2284	22284-	H3184	1 055	420	400	1 500	433	950	470	150	430	450
BND3084	23084-	H3084	435	420	400	1 100	310	755	340	115	420	440
BND3184	23184-	H3184	950	420	400	1 350	440	900	420	135	424	444
BND3284	23284-	H3284	1 310	420	400	1 500	510	950	470	150	430	450

¹⁾ Ordering example:
Housing BND3276-H-C-T-BL-S (see also page 1210), bearing 23276-B-K-MB (see bearing tables), adapter sleeve H3276-HG (see dimensions tables).

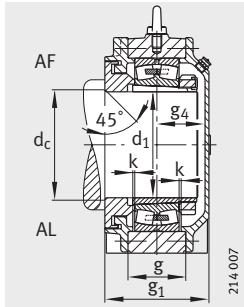

Design A
Housing with labyrinth seal for bearings
with tapered bore, shaft with abutment shoulder

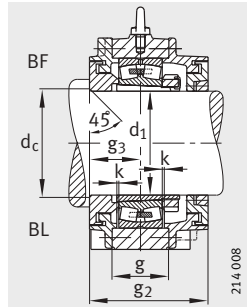

Design B
Housing with labyrinth seal for bearings
with tapered bore, shaft with abutment shoulder

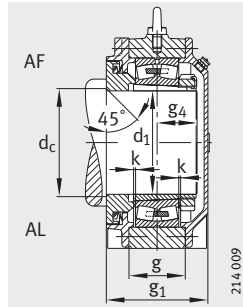

Design A
Housing with Taconite seal for bearings
with tapered bore, shaft with abutment shoulder

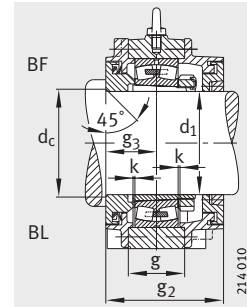

Design B
Housing with Taconite seal for bearings
with tapered bore, shaft with abutment shoulder

g	g ₃	g ₂	g ₄ min.	g ₅	h	k	m	n	u	v	s	t	s ₂	s ₂ Quantity
178	156	352	149	312	350	4	920	180	56	75	M48	600	M24	8
140	128	296	121	256	285	4	690	150	42	52	M36	510	M16	8
190	172	384	143	344	320	4	840	170	42	52	M36	555	M24	8
230	182	404	175	364	350	4	920	180	56	75	M48	600	M24	8
180	163	381	158	326	370	5	960	200	56	75	M48	640	M24	8
150	133	311	123	266	295	4	730	160	42	52	M36	530	M16	8
210	186	412	161	372	350	4	940	160	42	52	M36	590	M24	8
238	192	439	187	384	370	5	960	200	56	75	M48	640	M24	8
201	187,5	430	176	375	390	5	990	200	64	85	M56	680	M30	8
160	133	311	132	266	315	5	770	170	42	52	M36	565	M20	8
220	183	421	178	366	370	5	960	200	56	75	M48	640	M24	8
260	217	489	205	434	390	5	990	200	64	85	M56	680	M30	8
205	185	435	178	370	410	5	1040	210	72	90	M64	710	M30	8
170	140	325	138	280	330	5	820	180	42	52	M36	590	M20	8
225	200	450	188	400	380	4	1000	200	56	75	M48	650	M24	8
267	216	497	209	432	410	5	1040	210	72	90	M64	710	M30	8
230	203	470	218	406	425	5	1100	225	72	90	M64	745	M30	8
160	142	329	141	284	340	7	840	190	56	75	M48	610	M20	8
230	202	459	190	404	390	5	1000	200	64	85	M56	680	M30	8
295	232	529	244	464	425	5	1100	225	72	90	M64	745	M30	8
229	216,5	498	202	433	450	5	1160	240	72	90	M64	790	M30	8
175	150	355	145	300	360	7	900	200	56	75	M48	650	M20	8
235	200	465	193	400	410	5	1040	210	72	90	M64	710	M30	8
300	252	569	237	504	450	5	1160	240	72	90	M64	790	M30	8
238	216,5	498	202	433	470	5	1220	255	72	90	M64	835	M30	8
180	150	350	149	300	375	7	940	210	56	75	M48	670	M20	8
260	210	510	215	420	450	7	1100	210	64	85	M56	760	M30	8
315	255	575	240	510	470	5	1220	255	72	90	M64	835	M30	8



Flanged housings

F112, unsplit
For self-aligning
ball bearings with
extended inner ring

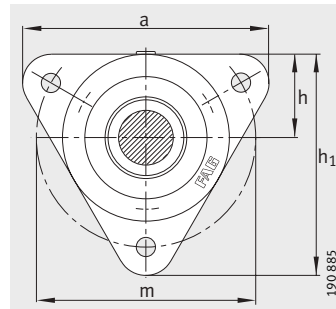

Design
F11204 to F11206

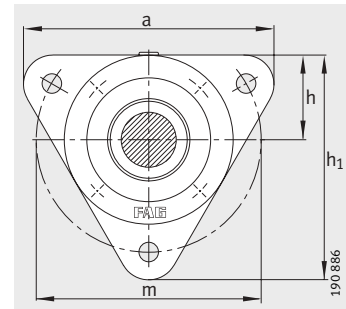

Design
F11207 to F11210

Dimension table · Dimensions in mm						
Designation						Mass m Housing ≈kg
Housing	Bearing	Cover ¹⁾		Felt strips		
			Quantity	aXbXl	Quantity	
F11204	11204-TVH	DK.F11204	1	5X4X108	1	0,9
F11205	11205-TVH	DK.F11205	1	5X4X120	1	1,1
F11206	11206-TVH	DK.F11206	1	5X4X145	1	1,5
F11207	11207-TVH	DK.F11207	1	5X4X165	1	1,9
F11208	11208-TVH	DK.F11208	1	5X4X185	1	2,3
F11209	11209-TVH	–	–	5X4X197	2	3,3
F11210	11210-TVH	–	–	5X4X213	2	3,6

¹⁾ The cover is included in the housing designation.

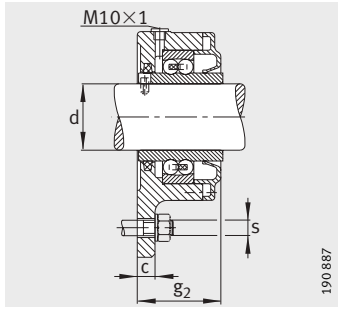

Design
F11204 to F11208

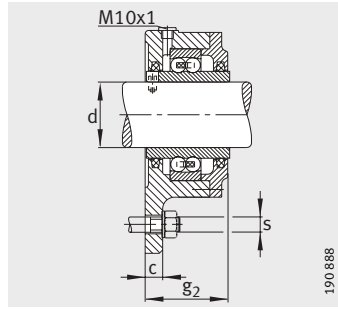

Design
F11209 to F11210

Dimensions

d	a	g ₂	h ₁	c	h	m	s	
							mm	inch
20	105	42	92	10	35	90	M10	3/8
25	110	46	100	10	38	96	M10	3/8
30	130	49	117	12	44	116	M10	3/8
35	145	54	129,5	12	48,5	130	M12	1/2
40	160	60	143	12	54	140	M12	1/2
45	180	62,5	160	15	60	160	M12	1/2
50	180	62,5	160	15	60	160	M12	1/2



Flanged housings

F5, unsplit
For bearings with tapered bore and adapter sleeve

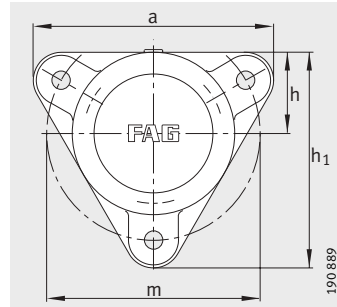

F505, F506, F508

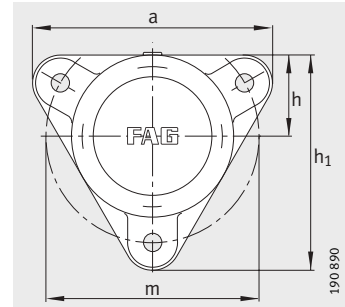

F507, F509 to F513

Dimension table · Dimensions in mm								
Designation								Mass m Housing ≈kg
Housing	Bearing		Adapter sleeve	Locating ring		Felt strips		
					Quantity	aXbXl	Quantity	
F505-A-L	1205-K-TVH-C3	20205-K-TVP-C3	H205	FE52/2	1	5X4X90	1	1,2
F505-B-L	1205-K-TVH-C3	20205-K-TVP-C3	H205	FE52/2	1	5X4X90	2	1,2
F505-WA-L	2205-K-TVH-C3	22205-E1-K	H305	FE52/2	1	5X4X90	1	1,2
F505-WB-L	2205-K-TVH-C3	22205-E1-K	H305	FE52/2	1	5X4X90	2	1,2
F506-A-L	1206-K-TVH-C3	20206-K-TVP-C3	H206	FE62/2	1	6X5X115	1	1,6
F506-B-L	1206-K-TVH-C3	20206-K-TVP-C3	H206	FE62/2	1	6X5X115	2	1,6
F506-WA-L	2206-K-TVH-C3	22206-E1-K	H306	FE62/2	1	6X5X115	1	1,6
F506-WB-L	2206-K-TVH-C3	22206-E1-K	H306	FE62/2	1	6X5X115	2	1,6
F507-A-L	1207-K-TVH-C3	20207-K-TVP-C3	H207	FE72/2	1	6X5X130	1	2
F507-B-L	1207-K-TVH-C3	20207-K-TVP-C3	H207	FE72/2	1	6X5X130	2	2
F507-WA-L	2207-K-TVH-C3	22207-E1-K	H307	FE72/2	1	6X5X130	1	2
F507-WB-L	2207-K-TVH-C3	22207-E1-K	H307	FE72/2	1	6X5X130	2	2
F508-A-L	1208-K-TVH-C3	20208-K-TVP-C3	H208	FE80/2	1	6X5X145	1	2,5
F508-B-L	1208-K-TVH-C3	20208-K-TVP-C3	H208	FE80/2	1	6X5X145	2	2,5
F508-WA-L	2208-K-TVH-C3	22208-E1-K	H308	FE80/2	1	6X5X145	1	2,5
F508-WB-L	2208-K-TVH-C3	22208-E1-K	H308	FE80/2	1	6X5X145	2	2,5
F509-A-L	1209-K-TVH-C3	20209-K-TVP-C3	H209	FE85/2	1	6X5X160	1	3,6
F509-B-L	1209-K-TVH-C3	20209-K-T-VPC3	H209	FE85/2	1	6X5X160	2	3,6
F509-WA-L	2209-K-TVH-C3	22209-E1-K	H309	FE85/2	1	6X5X160	1	3,6
F509-WB-L	2209-K-TVH-C3	22209-E1-K	H309	FE85/2	1	6X5X160	2	3,6
F510-A-L	1210-K-TVH-C3	20210-K-TVP-C3	H210	FE90/2	1	6X5X175	1	3,8
F510-B-L	1210-K-TVH-C3	20210-K-TVP-C3	H210	FE90/2	1	6X5X175	2	3,8
F510-WA-L	2210-K-TVH-C3	22210-E1-K	H310	FE90/2	1	6X5X175	1	3,8
F510-WB-L	2210-K-TVH-C3	22210-E1-K	H310	FE90/2	1	6X5X175	2	3,8
F511-A-L	1211-K-TVH-C3	20211-K-TVP-C3	H211	FE100/2	1	8X6,5X200	1	4,1
F511-B-L	1211-K-TVH-C3	20211-K-TVP-C3	H211	FE100/2	1	8X6,5X200	2	4,1
F511-WA-L	2211-K-TVH-C3	22211-E1-K	H311	FE100/2	1	8X6,5X200	1	4,1
F511-WB-L	2211-K-TVH-C3	22211-E1-K	H311	FE100/2	1	8X6,5X200	2	4,1
F512-A-L	1212-K-TVH-C3	20212-K-TVP-C3	H212	FE110/2	1	8X6,5X215	1	4,6
F512-B-L	1212-K-TVH-C3	20212-K-TVP-C3	H212	FE110/2	1	8X6,5X215	2	4,6
F512-WA-L	2212-K-TVH-C3	22212-E1-K	H312	FE110/2	1	8X6,5X215	1	4,6
F512-WB-L	2212-K-TVH-C3	22212-E1-K	H312	FE110/2	1	8X6,5X215	2	4,6
F513-A-L	1213-K-TVH-C3	20213-K-TVP-C3	H213	FE120/2	1	8X6,5X230	1	5,4
F513-B-L	1213-K-TVH-C3	20213-K-TVP-C3	H213	FE120/2	1	8X6,5X230	2	5,4
F513-WA-L	2213-K-TVH-C3	22213-E1-K	H313	FE120/2	1	8X6,5X230	1	5,4
F513-WB-L	2213-K-TVH-C3	22213-E1-K	H313	FE120/2	1	8X6,5X230	2	5,4

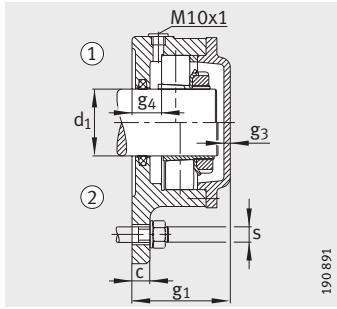

Design A
 ① Locating bearing
 ② Non-locating bearing

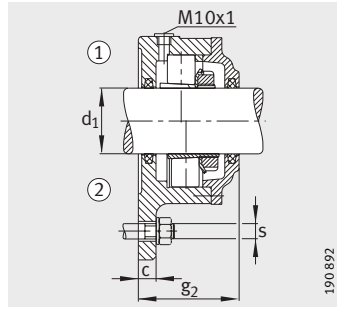

Design B
 ① Locating bearing
 ② Non-locating bearing

Dimensions												
d ₁	a	g ₂	h ₁	c	g ₁	g ₃	g ₄	h	m	s		
										mm	inch	
20	110	–	100	10	50	4	16	38	96	M10	³ / ₈	
20	110	55	100	10	–	–	16	38	96	M10	³ / ₈	
20	110	–	100	10	50	4	14,5	38	96	M10	³ / ₈	
20	110	55	100	10	–	–	14,5	38	96	M10	³ / ₈	
25	130	–	117	12	55	4	18	44	116	M10	³ / ₈	
25	130	57	117	12	–	–	18	44	116	M10	³ / ₈	
25	130	–	117	12	55	4	16	44	116	M10	³ / ₈	
25	130	57	117	12	–	–	16	44	116	M10	³ / ₈	
30	145	–	130	12	57	5	17	48,5	130	M12	¹ / ₂	
30	145	60	130	12	–	–	17	48,5	130	M12	¹ / ₂	
30	145	–	130	12	63	5	17	48,5	130	M12	¹ / ₂	
30	145	66	130	12	–	–	17	48,5	130	M12	¹ / ₂	
35	160	–	143	12	65	5	22	54	140	M12	¹ / ₂	
35	160	66	143	12	–	–	22	54	140	M12	¹ / ₂	
35	160	–	143	12	70	5	22	54	140	M12	¹ / ₂	
35	160	71	143	12	–	–	22	54	140	M12	¹ / ₂	
40	180	–	160	15	65	5	22	60	160	M12	¹ / ₂	
40	180	70	160	15	–	–	22	60	160	M12	¹ / ₂	
40	180	–	160	15	69	5	22	60	160	M12	¹ / ₂	
40	180	74	160	15	–	–	22	60	160	M12	¹ / ₂	
45	180	–	160	15	65	5	20	60	160	M12	¹ / ₂	
45	180	70	160	15	–	–	20	60	160	M12	¹ / ₂	
45	180	–	160	15	71	5	23	60	160	M12	¹ / ₂	
45	180	76	160	15	–	–	23	60	160	M12	¹ / ₂	
50	190	–	170	16	71	6	23	65	170	M12	¹ / ₂	
50	190	76	170	16	–	–	23	65	170	M12	¹ / ₂	
50	190	–	170	16	77	6	25	65	170	M12	¹ / ₂	
50	190	82	170	16	–	–	25	65	170	M12	¹ / ₂	
55	206	–	185	16	73	6	24	70	180	M12	¹ / ₂	
55	206	78	185	16	–	–	24	70	180	M12	¹ / ₂	
55	206	–	185	16	79	6	24	70	180	M12	¹ / ₂	
55	206	84	185	16	–	–	24	70	180	M12	¹ / ₂	
60	219	–	198	16	75	6	24	75	190	M12	¹ / ₂	
60	219	79	198	16	–	–	24	75	190	M12	¹ / ₂	
60	219	–	198	16	83	6	24	75	190	M12	¹ / ₂	
60	219	87	198	16	–	–	24	75	190	M12	¹ / ₂	



Flanged housings

F5, unsplit
For bearings with
tapered bore and adapter sleeve

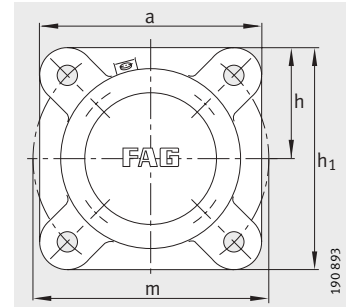

F515 to F522

Dimension table (continued) · Dimensions in mm								
Designation								Mass m Housing ≈ kg
Housing	Bearing		Adapter sleeve	Locating ring		Felt strips		
					Quantity	aXbXl	Quantity	
F515-A-L	1215-K-TVH-C3	20215-K-TVP-C3	H215	FRM130/8	2	8X6,5X245	1	9,5
F515-A-L	2215-K-TVH-C3	22215-E1-K	H315	FRM130/10	1	8X6,5X245	1	9,5
F515-B-L	1215-K-TVH-C3	20215-K-TVP-C3	H215	FRM130/8	2	8X6,5X245	2	9,5
F515-B-L	2215-K-TVH-C3	22215-E1-K	H315	FRM130/10	1	8X6,5X245	2	9,5
F516-A-L	1216-K-TVH-C3	20216-K-TVP-C3	H216	FRM140/8,5	2	9X7,5X270	1	10
F516-A-L	2216-K-TVH-C3	22216-E1-K	H316	FRM140/10	1	9X7,5X270	1	10
F516-B-L	1216-K-TVH-C3	20216-K-TVP-C3	H216	FRM140/8,5	2	9X7,5X270	2	10
F516-B-L	2216-K-TVH-C3	22216-E1-K	H316	FRM140/10	1	9X7,5X270	2	10
F517-A-L	1217-K-TVH-C3	20217-K-MB-C3	H217	FRM150/9	2	9X7,5X285	1	12
F517-A-L	2217-K-TVH-C3	22217-E1-K	H317	FRM150/10	1	9X7,5X285	1	12
F517-B-L	1217-K-TVH-C3	20217-K-MB-C3	H217	FRM150/9	2	9X7,5X285	2	12
F517-B-L	2217-K-TVH-C3	22217-E1-K	H317	FRM150/10	1	9X7,5X285	2	12
F518-A-L	1218-K-TVH-C3	20218-K-MB-C3	H218	FRM160/10	2	9X7,5X300	1	13
F518-A-L	2218-K-TVH-C3	22218-E1-K	H318	FRM160/10	1	9X7,5X300	1	13
F518-B-L	1218-K-TVH-C3	20218-K-MB-C3	H218	FRM160/10	2	9X7,5X300	2	13
F518-B-L	2218-K-TVH-C3	22218-E1-K	H318	FRM160/10	1	9X7,5X300	2	13
F520-A-L	1220-K-M-C3	20220-K-MB-C3	H220	FRM180/10 + FRM180/12	1 1	10X8,5X335	1	18
F520-A-L	2220-K-M-C3	22220-E1-K	H320	FRM180/10	1	10X8,5X335	1	18
F520-B-L	1220-K-M-C3	20220-K-MB-C3	H220	FRM180/10 + FRM180/12	1 1	10X8,5X335	2	18
F520-B-L	2220-K-M-C3	22220-E1-K	H320	FRM180/10	1	10X8,5X335	2	18
F522-A-L	1222-K-M-C3	20222-K-MB-C3	H222	FRM200/13,5	2	12X10X375	1	22
F522-B-L	1222-K-M-C3	20222-K-MB-C3	H222	FRM200/13,5	2	12X10X375	2	22
F522-WA-L	2222-K-M-C3	22222-E1-K	H322	FRM200/10	1	12X10X375	1	22
F522-WB-L	2222-K-M-C3	22222-E1-K	H322	FRM200/10	1	12X10X375	2	22

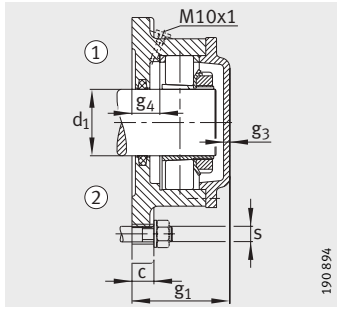

Design A
 ① Locating bearing
 ② Non-locating bearing

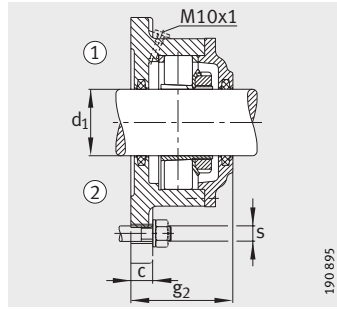

Design B
 ① Locating bearing
 ② Non-locating bearing

Dimensions

d ₁	a	g ₂	h ₁	c	g ₁	g ₃	g ₄	h	m	s	
										mm	inch
65	190	-	190	25	97	6	30	95	215	M16	5/8
65	190	-	190	25	97	6	30	95	215	M16	5/8
65	190	104	190	25	-	-	30	95	215	M16	5/8
65	190	104	190	25	-	-	30	95	215	M16	5/8
70	196	-	196	25	101	6	32	98	215	M16	5/8
70	196	-	196	25	101	6	32	98	215	M16	5/8
70	196	110	196	25	-	-	32	98	215	M16	5/8
70	196	110	196	25	-	-	32	98	215	M16	5/8
75	210	-	210	25	106	7	31	105	240	M16	5/8
75	210	-	210	25	106	7	31	105	240	M16	5/8
75	210	114	210	25	-	-	31	105	240	M16	5/8
75	210	114	210	25	-	-	31	105	240	M16	5/8
80	210	-	210	25	110	7	29	105	240	M16	5/8
80	210	-	210	25	110	7	29	105	240	M16	5/8
80	210	118	210	25	-	-	29	105	240	M16	5/8
80	210	118	210	25	-	-	29	105	240	M16	5/8
90	250	-	250	30	119	8	29	125	280	M20	3/4
90	250	-	250	30	119	8	29	125	280	M20	3/4
90	250	127	250	30	-	-	29	125	280	M20	3/4
90	250	127	250	30	-	-	29	125	280	M20	3/4
100	270	-	270	30	128	8	30	135	310	M20	3/4
100	270	137	270	30	-	-	30	135	310	M20	3/4
100	270	-	270	30	128	8	30	135	310	M20	3/4
100	270	137	270	30	-	-	30	135	310	M20	3/4



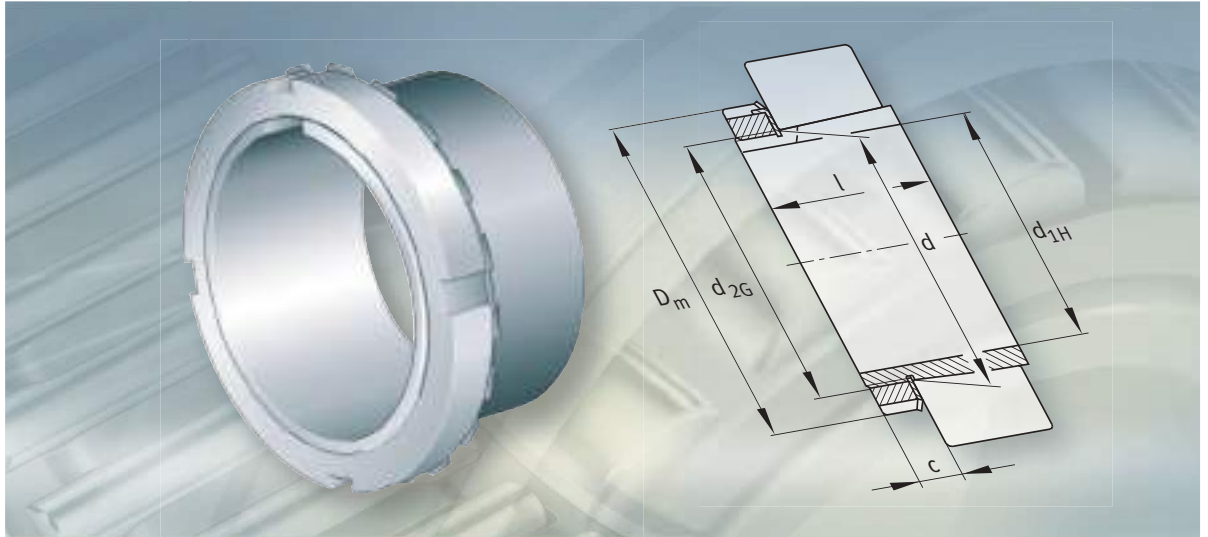

Fasteners and retainers

- Adapter sleeves
- Extraction sleeves
- Locknuts
- Retaining plates
- Retaining brackets

Fasteners and retainers

	Page
Product overview	Fasteners and retainers 1314
Features	Adapter sleeves..... 1315
	Extraction sleeves 1315
	Locknuts 1316
	Retaining plates 1316
	Retaining brackets 1316
	Suffixes..... 1316
Design and safety guidelines	Shaft tolerances 1317
Accuracy	Adapter sleeves..... 1317
	Extraction sleeves 1317
	Locknuts 1317
Dimension tables	Adapter sleeves..... 1318
	Extraction sleeves 1332
	Locknuts 1348
	Retaining plates 1352
	Retaining brackets 1354



Product overview Fasteners and retainers

Adapter sleeves
With nut and retainer,
taper 1:12 or 1:30

H2, H3, H23, H30, H31, H32, H33, H39, H240, H241

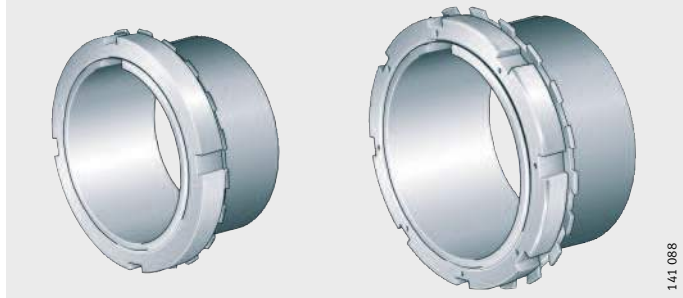

Extraction sleeves
Taper 1:12 or 1:30

AH2, AH(X)3, AH(X)23, AH(X)30, AH(X)31, AH(X)32,
AH33, AH39, AH240, AH241



Locknuts

KM, KML, HM



HM30, HM31



Retaining plates
Retaining brackets
with screw

MB, MBL

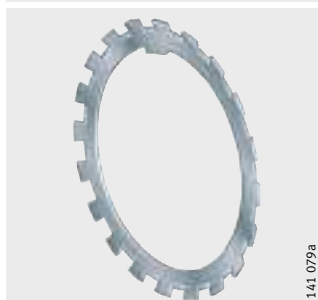

MS30, MS31



Fasteners and retainers

Features The location of bearings with a tapered bore on cylindrical shaft studs can be carried out using easy-to-fit, reliable adapter and extraction sleeves.
Locknuts can be used to fix bearings on shafts or adapter sleeves. Gradual loosening of nuts can be prevented using retaining plates or retaining brackets.

Adapter sleeves For smooth and stepped shafts

Adapter sleeves are suitable where bearings with a tapered bore are to be located on cylindrical shafts. They require no additional means of securing of the shaft. The bearings can be positioned at any point on smooth shafts.

If adapter sleeves are used with a support ring on stepped shafts, the bearings can be axially located to high accuracy. This also simplifies dismantling of the bearings.

Adapter sleeves comprise slotted adapter sleeves, locknuts and retaining plates. For larger sizes, retaining brackets are used instead of retaining plates.

The tensile strength of the material is at least 430 N/mm^2 . The outside surface of the sleeves has a taper of 1:12, in series H240 and H241 the taper is 1:30.

The dimension tables describe adapter sleeves for metric shafts. Sleeves for inch size shafts are available by agreement.

For hydraulic method

Fitting and dismantling of large bearings requires high mounting forces and is made easier by using the hydraulic method. There are adapter sleeves with oil slots on the tapered outside surface and a pump connector on the thread side. These adapter sleeves have the suffix HG. The dimension tables describe the thread for the pump connector.

Extraction sleeves

Extraction sleeves are suitable where bearings with a tapered bore are to be located on cylindrical shafts. The tapered sleeve is pressed into the bearing bore until the required reduction in radial internal clearance is achieved. The bearing is abutted, for example against a shoulder on the shaft.

Retainers are not included in the delivery.

The tensile strength of the material is at least 430 N/mm^2 .

The outside surface of the slotted steel sleeves has a taper of 1:12, in series AH240 and AH241 the taper is 1:30.

For hydraulic method

Fitting and dismantling of large bearings requires high mounting forces and is made easier by using the hydraulic method. There are extraction sleeves with oil slots on the tapered outside surface and two pump connectors offset to each other by 90° . These extraction sleeves have the suffix H. The dimension tables give the mounting dimensions for the pump connector.



Fasteners and retainers

Locknuts Locknuts can be used to fix bearings on shafts or adapter sleeves. They also give easier mounting of bearings with a tapered shaft seat and the fitting and dismantling of bearings on extraction sleeves. The locknuts are made from steel and the tensile strength of the material is at least 350 N/mm². They have four or eight evenly spaced slots on the circumference, into which hook wrenches or striking-face wrenches can be fitted. By agreement, locknuts of series HM30..-H, HM31..-H with threaded holes for mounting screws are available. Precision locknuts are described in the section Bearings for screw drives and in the publication AC 41161.

Retaining plates Retaining plates MB and MBL are simple, reliable elements for securing smaller locknuts (nuts of series KM and KML). They have an inner tab and several outer tabs evenly spaced around the circumference. The inner tab grips in the slot on the adapter sleeve or shaft, one of the outer tabs is bent to give location in the slot in the nut. The plates are made from steel and the tensile strength of the material is at least 300 N/mm².

Retaining brackets Retaining brackets of series MS are fixed to the locknut using a hexagonal screw. They grip in a slot in the nut and in the adapter sleeve or shaft. The fixing screw has a self-locking thread up to M16, from M20 a standardised hexagonal screw with a retainer is used. Retaining brackets are used with locknuts of series HM30 and HM31.

Suffixes Suffixes for the available designs: see table.

Available designs

Suffix	Description
H	Hydraulic extraction sleeve
HG	Hydraulic adapter sleeve

**Design and
safety guidelines**
Shaft tolerances

Adapter and extraction sleeves adapt themselves to the shaft. Larger diameter tolerances are therefore permissible for shafts than in the case of a direct cylindrical seat for a bearing on the shaft.

For general applications, bearing seats toleranced to h9 are sufficient.

The geometrical tolerances must be tighter than the diameter tolerances since the geometrical accuracy affects the running accuracy of the bearing arrangement. The cylindricity tolerance of the bearing seat should be within IT5/2 or IT6/2.

Accuracy
Adapter sleeves

The dimensions and material conform to DIN 5 415/ISO 2 982-1.

The bore tolerance of adapter sleeves, before slitting, is in the tolerance zone JS9 for the 1:12 taper and JS7 for the 1:30 taper.

Up to M200, the thread is a metric precision thread with tolerance grade 6g to DIN/ISO 965-3, trapezoidal threads are used over M200.

Extraction sleeves

The dimensions and material conform to DIN 5 416/ISO 2 982-1.

The bore tolerance of adapter sleeves, before slitting, is in the tolerance zone JS9 for the 1:12 taper and JS7 for the 1:30 taper.

Up to M200, the thread is a metric precision thread with tolerance grade 6g to DIN/ISO 965-3, trapezoidal threads are used over M200.

Variants with a modified thread d_{2G} have the suffix G.

Locknuts

The dimensions and material conform to DIN 981/ISO 2 982-2. Deviations are indicated in the dimension tables.

Up to a thread diameter 200 mm, the thread is a metric precision thread, larger locknuts have trapezoidal threads.



Adapter sleeves

With nut and retainer

Dimension table · Dimensions in mm									
Designation			Mass m ≈kg	Dimensions					
Adapter sleeve Complete	Nut	Retainer		d _{1H}	d	D _m ≈	l	c ≈	d _{2G}
H203	KM3	MB3	0,03	14	17	28	21	6	M17X1
H204	KM4	MB4	0,04	17	20	32	24	7	M20X1
H304	KM4	MB4	0,04	17	20	32	28	7	M20X1
H2304	KM4	MB4	0,05	17	20	32	31	7	M20X1
H205	KM5	MB5	0,07	20	25	38	26	9	M25X1,5
H305	KM5	MB5	0,07	20	25	38	29	9	M25X1,5
H2305	KM5	MB5	0,09	20	25	38	35	9	M25X1,5
H206	KM6	MB6	0,1	25	30	45	27	9	M30X1,5
H306	KM6	MB6	0,11	25	30	45	31	9	M30X1,5
H2306	KM6	MB6	0,13	25	30	45	38	9	M30X1,5
H207	KM7	MB7	0,12	30	35	52	29	10	M35X1,5
H307	KM7	MB7	0,14	30	35	52	35	10	M35X1,5
H2307	KM7	MB7	0,16	30	35	52	43	10	M35X1,5
H208	KM8	MB8	0,18	35	40	58	31	11	M40X1,5
H308	KM8	MB8	0,19	35	40	58	36	11	M40X1,5
H2308	KM8	MB8	0,23	35	40	58	46	11	M40X1,5
H3308	KM8	MB8	0,24	35	40	58	50	11	M40X1,5
H209	KM9	MB9	0,22	40	45	65	33	12	M45X1,5
H309	KM9	MB9	0,25	40	45	65	39	12	M45X1,5
H2309	KM9	MB9	0,29	40	45	65	50	12	M45X1,5
H3309	KM9	MB9	0,31	40	45	65	54	12	M45X1,5
H210	KM10	MB10	0,27	45	50	70	35	13	M50X1,5
H310	KM10	MB10	0,3	45	50	70	42	13	M50X1,5
H2310	KM10	MB10	0,36	45	50	70	55	13	M50X1,5
H3310	KM10	MB10	0,39	45	50	70	60	13	M50X1,5
H211	KM11	MB11	0,31	50	55	75	37	13	M55X2
H311	KM11	MB11	0,35	50	55	75	45	13	M55X2
H2311	KM11	MB11	0,42	50	55	75	59	13	M55X2
H3311	KM11	MB11	0,46	50	55	75	65	13	M55X2
H212	KM12	MB12	0,35	55	60	80	38	13	M60X2
H312	KM12	MB12	0,4	55	60	80	47	13	M60X2
H2312	KM12	MB12	0,49	55	60	80	62	13	M60X2
H3312	KM12	MB12	0,54	55	60	80	70	13	M60X2

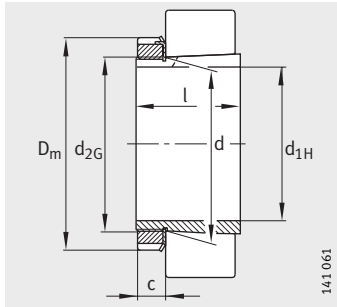

Taper 1:12
(taper 1:30 for H240, H241)
Retaining plate MB

Dimension table (continued) · Dimensions in mm									
Designation			Mass m ≈ kg	Dimensions					
Adapter sleeve Complete	Nut	Retainer		d _{1H}	d	D _m ≈	l	c ≈	d _{2G}
H213	KM13	MB13	0,4	60	65	85	40	14	M65X2
H313	KM13	MB13	0,46	60	65	85	50	14	M65X2
H2313	KM13	MB13	0,56	60	65	85	65	14	M65X2
H3313	KM13	MB13	0,63	60	65	85	75	14	M65X2
H214	KM14	MB14	0,63	60	70	92	41	14	M70X2
H314	KM14	MB14	0,74	60	70	92	52	14	M70X2
H2314	KM14	MB14	0,92	60	70	92	68	14	M70X2
H3314	KM14	MB14	1,08	60	70	92	81	14	M70X2
H215	KM15	MB15	0,71	65	75	98	43	15	M75X2
H315	KM15	MB15	0,84	65	75	98	55	15	M75X2
H2315	KM15	MB15	1,06	65	75	98	73	15	M75X2
H3315	KM15	MB15	1,25	65	75	98	87	15	M75X2
H216	KM16	MB16	0,89	70	80	105	46	17	M80X2
H316	KM16	MB16	1,04	70	80	105	59	17	M80X2
H2316	KM16	MB16	1,3	70	80	105	78	17	M80X2
H3316	KM16	MB16	1,46	70	80	105	89	17	M80X2
H217	KM17	MB17	1,03	75	85	110	50	18	M85X2
H317	KM17	MB17	1,19	75	85	110	63	18	M85X2
H2317	KM17	MB17	1,47	75	85	110	82	18	M85X2
H3317	KM17	MB17	1,68	75	85	110	95	18	M85X2
H218	KM18	MB18	1,21	80	90	120	52	18	M90X2
H318	KM18	MB18	1,39	80	90	120	65	18	M90X2
H2318	KM18	MB18	1,71	80	90	120	86	18	M90X2
H3318	KM18	MB18	1,87	80	90	120	95	18	M90X2
H219	KM19	MB19	1,39	85	95	125	55	19	M95X2
H319	KM19	MB19	1,58	85	95	125	68	19	M95X2
H2319	KM19	MB19	1,95	85	95	125	90	19	M95X2
H3319	KM19	MB19	2,16	85	95	125	101	19	M95X2
H220	KM20	MB20	1,52	90	100	130	58	20	M100X2
H320	KM20	MB20	1,73	90	100	130	71	20	M100X2
H3120	KM20	MB20	1,81	90	100	130	76	20	M100X2
H24020	KM20	MB20	1,77	90	100	130	80	20	M100X2
H24120	KM20	MB20	1,97	90	100	130	94	20	M100X2
H2320	KM20	MB20	2,2	90	100	130	97	20	M100X2
H3320	KM20	MB20	2,38	90	100	130	106	20	M100X2



Adapter sleeves

With nut and retainer

Dimension table (continued) - Dimensions in mm									
Designation			Mass	Dimensions					
Adapter sleeve Complete	Nut	Retainer	m	d _{1H}	d	D _m	l	c	d _{2G}
			≈kg			≈	≈		
H221	KM21	MB21	1,74	95	105	140	60	20	M105X2
H321	KM21	MB21	1,97	95	105	140	74	20	M105X2
H3121	KM21	MB21	2,09	95	105	140	80	20	M105X2
H2321	KM21	MB21	2,5	95	105	140	101	20	M105X2
H3321	KM21	MB21	2,71	95	105	140	111	20	M105X2
H222	KM22	MB22	1,95	100	110	145	63	21	M110X2
H322	KM22	MB22	2,21	100	110	145	77	21	M110X2
H3122	KM22	MB22	2,28	100	110	145	81	21	M110X2
H24022	KM22	MB22	2,3	100	110	145	90	21	M110X2
H24122	KM22	MB22	2,45	100	110	145	99	21	M110X2
H2322	KM22	MB22	2,78	100	110	145	105	21	M110X2
H3322	KM22	MB22	3,06	100	110	145	117	21	M110X2
H3924	KML24	MBL24	1,78	110	120	145	60	22	M120X2
H3024	KML24	MBL24	2,01	110	120	145	72	22	M120X2
H24024	KML24	MBL24	2,24	110	120	145	91	22	M120X2
H3124	KM24	MB24	2,67	110	120	155	88	22	M120X2
H24124	KM24	MB24	2,92	110	120	155	111	22	M120X2
H2324	KM24	MB24	3,24	110	120	155	112	22	M120X2
H3324	KM24	MB24	3,77	110	120	155	132	22	M120X2
H3926	KML26	MBL26	2,53	115	130	155	65	23	M130X2
H3026	KML26	MBL26	2,96	115	130	155	80	23	M130X2
H24026	KML26	MBL26	3,4	115	130	155	102	23	M130X2
H3126	KM26	MB26	3,72	115	130	165	92	23	M130X2
H24126	KM26	MB26	4,08	115	130	165	113	23	M130X2
H2326	KM26	MB26	4,69	115	130	165	121	23	M130X2
H3326	KM26	MB26	5,35	115	130	165	139	23	M130X2
H3928	KML28	MBL28	2,81	125	140	165	66	24	M140X2
H3028	KML28	MBL28	3,3	125	140	165	82	24	M140X2
H24028	KML28	MBL28	3,75	125	140	165	103	24	M140X2
H3128	KM28	MB28	4,4	125	140	180	97	24	M140X2
H24128	KM28	MB28	4,81	125	140	180	119	24	M140X2
H2328	KM28	MB28	5,66	125	140	180	131	24	M140X2
H3328	KM28	MB28	6,32	125	140	180	147	24	M140X2

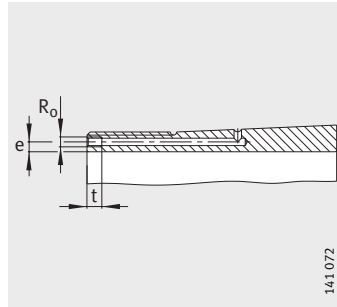
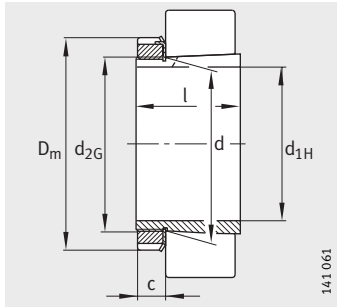

Taper 1:12
(taper 1:30 for H240, H241)
Retaining plate MB, MBL

Hydraulic adapter sleeve
(suffix HG)
Mounting dimensions

Dimension table (continued) · Dimensions in mm												
Designation			Mass m ≈ kg	Dimensions						Mounting dimensions		
Adapter sleeve Complete	Nut	Retainer		d _{1H}	d	D _m	l	c	d _{2G}	R ₀	e	t
H3930	KML30	MBL30	3,64	135	150	180	76	26	M150X2	–	–	–
H3030	KML30	MBL30	4,02	135	150	180	87	26	M150X2	–	–	–
H24030	KML30	MBL30	4,61	135	150	180	112	26	M150X2	–	–	–
H3130	KM30	MB30	5,6	135	150	195	111	26	M150X2	–	–	–
H24130	KM30	MB30	6,1	135	150	195	137	26	M150X2	–	–	–
H2330	KM30	MB30	6,76	135	150	195	139	26	M150X2	–	–	–
H3330	KM30	MB30	7,66	135	150	195	159	26	M150X2	–	–	–
H3932	KML32	MBL32	4,75	140	160	190	78	28	M160X3	–	–	–
H3932-HG	KML32	MBL32	4,75	140	160	190	78	28	M160X3	M6	4,2	7
H3032	KML32	MBL32	5,44	140	160	190	93	28	M160X3	–	–	–
H3032-HG	KML32	MBL32	5,44	140	160	190	93	28	M160X3	M6	4,2	7
H24032	KML32	MBL32	6,27	140	160	190	118	28	M160X3	–	–	–
H24032-HG	KML32	MBL32	6,27	140	160	190	118	28	M160X3	M6	4,2	7
H3132	KM32	MB32	7,81	140	160	210	119	28	M160X3	–	–	–
H3132-HG	KM32	MB32	7,81	140	160	210	119	28	M160X3	M6	4,2	7
H2332	KM32	MB32	9,32	140	160	210	147	28	M160X3	–	–	–
H2332-HG	KM32	MB32	9,32	140	160	210	147	28	M160X3	M6	4,2	7
H24132	KM32	MB32	8,66	140	160	210	148	28	M160X3	–	–	–
H24132-HG	KM32	MB32	8,66	140	160	210	148	28	M160X3	M6	4,2	7
H3332	KM32	MB32	10,7	140	160	210	170	28	M160X3	–	–	–
H3332-HG	KM32	MB32	10,7	140	160	210	170	28	M160X3	M6	4,2	7
H3934	KML34	MBL34	5,16	150	170	200	79	29	M170X3	–	–	–
H3934-HG	KML34	MBL34	5,16	150	170	200	79	29	M170X3	M6	4,2	7
H3034	KML34	MBL34	6,25	150	170	200	101	29	M170X3	–	–	–
H3034-HG	KML34	MBL34	6,25	150	170	200	101	29	M170X3	M6	4,2	7
H24034	KML34	MBL34	7,28	150	170	200	130	29	M170X3	–	–	–
H24034-HG	KML34	MBL34	7,28	150	170	200	130	29	M170X3	M6	4,2	7
H3134	KM34	MB34	8,52	150	170	220	122	29	M170X3	–	–	–
H3134-HG	KM34	MB34	8,52	150	170	220	122	29	M170X3	M6	4,2	7
H24134	KM34	MB34	9,32	150	170	220	149	29	M170X3	–	–	–
H24134-HG	KM34	MB34	9,32	150	170	220	149	29	M170X3	M6	4,2	7
H2334	KM34	MB34	10,4	150	170	220	154	29	M170X3	–	–	–
H2334-HG	KM34	MB34	10,4	150	170	220	154	29	M170X3	M6	4,2	7
H3334	KM34	MB34	11,7	150	170	220	175	29	M170X3	–	–	–
H3334-HG	KM34	MB34	11,7	150	170	220	175	29	M170X3	M6	4,2	7



Adapter sleeves

With nut and retainer

Dimension table (continued) - Dimensions in mm												
Designation			Mass	Dimensions						Mounting dimensions		
Adapter sleeve Complete	Nut	Retainer	m	d _{1H}	d	D _m	l	c	d _{2G}	R ₀	e	t
			≈ kg			≈	≈					
H3936	KML36	MBL36	6,01	160	180	210	87	30	M180X3	–	–	–
H3936-HG	KML36	MBL36	6,01	160	180	210	87	30	M180X3	M6	4,2	7
H3036	KML36	MBL36	7,18	160	180	210	109	30	M180X3	–	–	–
H3036-HG	KML36	MBL36	7,18	160	180	210	109	30	M180X3	M6	4,2	7
H24036	KML36	MBL36	8,33	160	180	210	140	30	M180X3	–	–	–
H24036-HG	KML36	MBL36	8,33	160	180	210	140	30	M180X3	M6	4,2	7
H3136	KM36	MB36	9,67	160	180	230	131	30	M180X3	–	–	–
H3136-HG	KM36	MB36	9,67	160	180	230	131	30	M180X3	M6	4,2	7
H24136	KM36	MB36	10,5	160	180	230	159	30	M180X3	–	–	–
H24136-HG	KM36	MB36	10,5	160	180	230	159	30	M180X3	M6	4,2	7
H2336	KM36	MB36	11,6	160	180	230	161	30	M180X3	–	–	–
H2336-HG	KM36	MB36	11,6	160	180	230	161	30	M180X3	M6	4,2	7
H3336	KM36	MB36	13,3	160	180	230	186	30	M180X3	–	–	–
H3336-HG	KM36	MB36	13,3	160	180	230	186	30	M180X3	M6	4,2	7
H3938	KML38	MBL38	6,49	170	190	220	89	31	M190X3	–	–	–
H3938-HG	KML38	MBL38	6,49	170	190	220	89	31	M190X3	M6	4,2	7
H3038	KML38	MBL38	7,8	170	190	220	112	31	M190X3	–	–	–
H3038-HG	KML38	MBL38	7,8	170	190	220	112	31	M190X3	M6	4,2	7
H24038	KML38	MBL38	9	170	190	220	143	31	M190X3	–	–	–
H24038-HG	KML38	MBL38	9	170	190	220	143	31	M190X3	M6	4,2	7
H3138	KM38	MB38	11	170	190	240	141	31	M190X3	–	–	–
H3138-HG	KM38	MB38	11	170	190	240	141	31	M190X3	M6	4,2	7
H2338	KM38	MB38	12,9	170	190	240	169	31	M190X3	–	–	–
H2338-HG	KM38	MB38	12,9	170	190	240	169	31	M190X3	M6	4,2	7
H24138	KM38	MB38	11,9	170	190	240	172	31	M190X3	–	–	–
H24138-HG	KM38	MB38	11,9	170	190	240	172	31	M190X3	M6	4,2	7
H3338	KM38	MB38	14,7	170	190	240	193	31	M190X3	–	–	–
H3338-HG	KM38	MB38	14,7	170	190	240	193	31	M190X3	M6	4,2	7

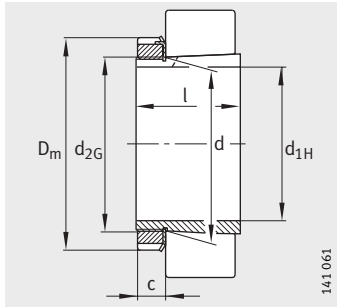

Taper 1:12
(taper 1:30 for H240, H241)
Retaining plate MB, MBL

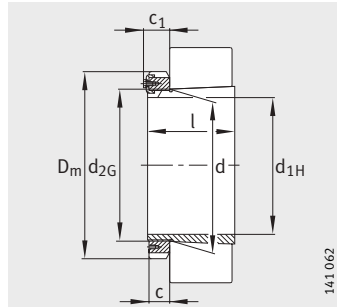

Taper 1:12
(taper 1:30 for H240)
Retaining bracket MS30

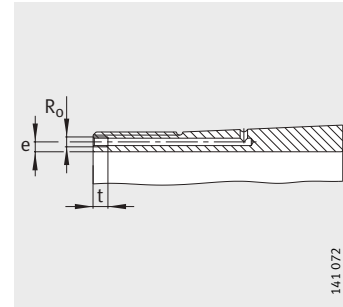

Hydraulic adapter sleeve
(suffix HG)
Mounting dimensions

Dimension table (continued) · Dimensions in mm													
Designation			Mass m ≈ kg	Dimensions							Mounting dimensions		
Adapter sleeve Complete	Nut	Retainer		d _{1H}	d	D _m	l	c ≈	c ₁ ≈	d _{2G}	R ₀	e	t
H3940	KML40	MBL40	8,14	180	200	240	98	32	–	M200X3	–	–	–
H3940-HG	KML40	MBL40	8,14	180	200	240	98	32	–	M200X3	M6	4,2	7
H3040	KML40	MBL40	9,5	180	200	240	120	32	–	M200X3	–	–	–
H3040-HG	KML40	MBL40	9,5	180	200	240	120	32	–	M200X3	M6	4,2	7
H24040	KML40	MBL40	10,8	180	200	240	153	32	–	M200X3	–	–	–
H24040-HG	KML40	MBL40	10,8	180	200	240	153	32	–	M200X3	M6	4,2	7
H3140	KM40	MB40	12,3	180	200	250	150	32	–	M200X3	–	–	–
H3140-HG	KM40	MB40	12,3	180	200	250	150	32	–	M200X3	M6	4,2	7
H2340	KM40	MB40	14,2	180	200	250	176	32	–	M200X3	–	–	–
H2340-HG	KM40	MB40	14,2	180	200	250	176	32	–	M200X3	M6	4,2	7
H24140	KM40	MB40	13,4	180	200	250	185	32	–	M200X3	–	–	–
H24140-HG	KM40	MB40	13,4	180	200	250	185	32	–	M200X3	M6	4,2	7
H3340	KM40	MB40	16,4	180	200	250	204	32	–	M200X3	–	–	–
H3340-HG	KM40	MB40	16,4	180	200	250	204	32	–	M200X3	M6	4,2	7
H3944	HM3044	MS3044	8,45	200	220	260	96	30	40	Tr220X4	–	–	–
H3944-HG	HM3044	MS3044	8,45	200	220	260	96	30	40	Tr220X4	M6	4,2	7
H3044X	HM3044	MS3044	10,5	200	220	260	126	30	40	Tr220X4	–	–	–
H3044X-HG	HM3044	MS3044	10,5	200	220	260	126	30	40	Tr220X4	M6	4,2	7
H24044	HM3044	MS3044	12,1	200	220	260	162	30	40	Tr220X4	–	–	–
H24044-HG	HM3044	MS3044	12,1	200	220	260	162	30	40	Tr220X4	M6	4,2	7
H3144X	HM44T	MB44	15,7	200	220	280	161	35	–	Tr220X4	–	–	–
H3144X-HG	HM44T	MB44	15,7	200	220	280	161	35	–	Tr220X4	M6	4,2	7
H2344X	HM44T	MB44	17,8	200	220	280	186	35	–	Tr220X4	–	–	–
H2344X-HG	HM44T	MB44	17,8	200	220	280	186	35	–	Tr220X4	M6	4,2	7
H24144	HM44T	MB44	17,1	200	220	280	199	35	–	Tr220X4	–	–	–
H24144-HG	HM44T	MB44	17,1	200	220	280	199	35	–	Tr220X4	M6	4,2	7
H3344	HM44T	MB44	21,1	200	220	280	223	35	–	Tr220X4	–	–	–
H3344-HG	HM44T	MB44	21,1	200	220	280	223	35	–	Tr220X4	M6	4,2	7



Adapter sleeves

With nut and retainer

Dimension table (continued) · Dimensions in mm													
Designation			Mass m ≈kg	Dimensions							Mounting dimensions		
Adapter sleeve Complete	Nut	Retainer		d _{1H}	d	D _m	l	c	c ₁	d _{2G}	R ₀	e	t
H3948	HM3048	MS3048	11,3	220	240	290	101	34	45	Tr240X4	–	–	–
H3948-HG	HM3048	MS3048	11,3	220	240	290	101	34	45	Tr240X4	M6	4,2	7
H3048	HM3048	MS3048	13,8	220	240	290	133	34	45	Tr240X4	–	–	–
H3048-HG	HM3048	MS3048	13,8	220	240	290	133	34	45	Tr240X4	M6	4,2	7
H24048	HM3048	MS3048	15,3	220	240	290	167	34	45	Tr240X4	–	–	–
H24048-HG	HM3048	MS3048	15,3	220	240	290	167	34	45	Tr240X4	M6	4,2	7
H3148X	HM48T	MB48	18,4	220	240	300	172	37	–	Tr240X4	–	–	–
H3148X-HG	HM48T	MB48	18,4	220	240	300	172	37	–	Tr240X4	M6	4,2	7
H2348X	HM48T	MB48	20,9	220	240	300	199	37	–	Tr240X4	–	–	–
H2348X-HG	HM48T	MB48	20,9	220	240	300	199	37	–	Tr240X4	M6	4,2	7
H24148	HM48T	MB48	19,9	220	240	300	212	37	–	Tr240X4	–	–	–
H24148-HG	HM48T	MB48	19,9	220	240	300	212	37	–	Tr240X4	M6	4,2	7
H3348	HM48T	MB48	25,1	220	240	300	240	37	–	Tr240X4	–	–	–
H3348-HG	HM48T	MB48	25,1	220	240	300	240	37	–	Tr240X4	M6	4,2	7
H3952	HM3052	MS3048	13,6	240	260	310	116	34	45	Tr260X4	–	–	–
H3952-HG	HM3052	MS3048	13,6	240	260	310	116	34	45	Tr260X4	M6	4,2	7
H3052X	HM3052	MS3048	16	240	260	310	145	34	45	Tr260X4	–	–	–
H3052X-HG	HM3052	MS3048	16	240	260	310	145	34	45	Tr260X4	M6	4,2	7
H24052	HM3052	MS3048	18,4	240	260	310	190	34	45	Tr260X4	–	–	–
H24052-HG	HM3052	MS3048	18,4	240	260	310	190	34	45	Tr260X4	M6	4,2	7
H3152X	HM52T	MB52	23,5	240	260	330	190	38	–	Tr260X4	–	–	–
H3152X-HG	HM52T	MB52	23,5	240	260	330	190	38	–	Tr260X4	M6	4,2	7
H2352X	HM52T	MB52	25,7	240	260	330	211	38	–	Tr260X4	–	–	–
H2352X-HG	HM52T	MB52	25,7	240	260	330	211	38	–	Tr260X4	M6	4,2	7
H24152	HM52T	MB52	25,2	240	260	330	235	38	–	Tr260X4	–	–	–
H24152-HG	HM52T	MB52	25,2	240	260	330	235	38	–	Tr260X4	M6	4,2	7
H3352	HM52T	MB52	30,5	240	260	330	253	38	–	Tr260X4	–	–	–
H3352-HG	HM52T	MB52	30,5	240	260	330	253	38	–	Tr260X4	M6	4,2	7

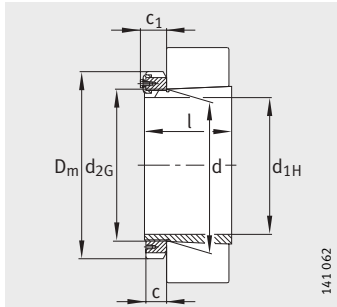

Taper 1:12
(taper 1:30 for H240, H241)
Retaining bracket MS30, MS31

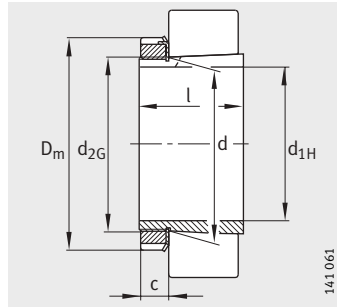

Taper 1:12
(taper 1:30 for H241)
Retaining plate MB

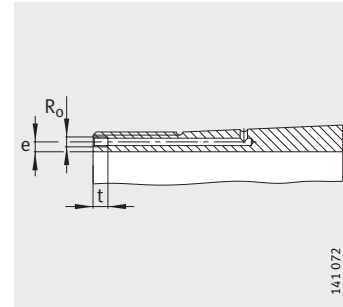

Hydraulic adapter sleeve
(suffix HG)
Mounting dimensions

Dimension table (continued) · Dimensions in mm

Designation			Mass m ≈kg	Dimensions							Mounting dimensions		
Adapter sleeve Complete	Nut	Retainer		d _{1H}	d	D _m	l	c	c ₁	d _{2G}	R ₀	e	t
H3956	HM3056	MS3056	15,6	260	280	330	121	38	49	Tr280X4	–	–	–
H3956-HG	HM3056	MS3056	15,6	260	280	330	121	38	49	Tr280X4	M6	4,2	7
H3056	HM3056	MS3056	18,5	260	280	330	152	38	49	Tr280X4	–	–	–
H3056-HG	HM3056	MS3056	18,5	260	280	330	152	38	49	Tr280X4	M6	4,2	7
H24056	HM3056	MS3056	20,9	260	280	330	195	38	49	Tr280X4	–	–	–
H24056-HG	HM3056	MS3056	20,9	260	280	330	195	38	49	Tr280X4	M6	4,2	7
H3156X	HM56T	MB56	26,4	260	280	350	195	39	–	Tr280X4	–	–	–
H3156X-HG	HM56T	MB56	26,4	260	280	350	195	39	–	Tr280X4	M6	4,2	7
H2356X	HM56T	MB56	29,8	260	280	350	224	39	–	Tr280X4	–	–	–
H2356X-HG	HM56T	MB56	29,8	260	280	350	224	39	–	Tr280X4	M6	4,2	7
H24156	HM56T	MB56	28	260	280	350	238	39	–	Tr280X4	–	–	–
H24156-HG	HM56T	MB56	28	260	280	350	238	39	–	Tr280X4	M6	4,2	7
H3356	HM56T	MB56	36	260	280	350	273	39	–	Tr280X4	–	–	–
H3356-HG	HM56T	MB56	36	260	280	350	273	39	–	Tr280X4	M6	4,2	7
H3960	HM3060	MS3060	20,9	280	300	360	140	42	53	Tr300X4	–	–	–
H3960-HG	HM3060	MS3060	20,9	280	300	360	140	42	53	Tr300X4	M6	4,2	7
H3060	HM3060	MS3060	23,8	280	300	360	168	42	53	Tr300X4	–	–	–
H3060-HG	HM3060	MS3060	23,8	280	300	360	168	42	53	Tr300X4	M6	4,2	7
H24060	HM3060	MS3060	26,9	280	300	360	220	42	53	Tr300X4	–	–	–
H24060-HG	HM3060	MS3060	26,9	280	300	360	220	42	53	Tr300X4	M6	4,2	7
H3160	HM3160	MS3160	30,6	280	300	380	208	40	53	Tr300X4	–	–	–
H3160-HG	HM3160	MS3160	30,6	280	300	380	208	40	53	Tr300X4	M6	4,2	7
H3260	HM3160	MS3160	34,7	280	300	380	240	40	53	Tr300X4	–	–	–
H3260-HG	HM3160	MS3160	34,7	280	300	380	240	40	53	Tr300X4	M6	4,2	7
H24160	HM3160	MS3160	32,7	280	300	380	258	40	53	Tr300X4	–	–	–
H24160-HG	HM3160	MS3160	32,7	280	300	380	258	40	53	Tr300X4	M6	4,2	7
H3360	HM3160	MS3160	40,8	280	300	380	284	40	53	Tr300X4	–	–	–
H3360-HG	HM3160	MS3160	40,8	280	300	380	284	40	53	Tr300X4	M6	4,2	7
H3964-HG	HM3064	MS3064	22	300	320	380	140	42	56	Tr320X5	M6	3,5	7
H3064-HG	HM3064	MS3064	25,4	300	320	380	171	42	56	Tr320X5	M6	3,5	7
H24064-HG	HM3064	MS3064	28,4	300	320	380	220	42	56	Tr320X5	M6	3,5	7
H3164-HG	HM3164	MS3164	35,4	300	320	400	226	42	56	Tr320X5	M6	3,5	7
H3264-HG	HM3164	MS3164	40	300	320	400	258	42	56	Tr320X5	M6	3,5	7
H24164-HG	HM3164	MS3164	37,4	300	320	400	278	42	56	Tr320X5	M6	3,5	7
H3364-HG	HM3164	MS3164	47,8	300	320	400	308	42	56	Tr320X5	M6	3,5	7



Adapter sleeves

With nut and retainer

Dimension table (continued) · Dimensions in mm													
Designation			Mass m ≈kg	Dimensions							Mounting dimensions		
Adapter sleeve Complete	Nut	Retainer		d _{1H}	d	D _m	l	c	c ₁	d _{2G}	R ₀	e	t
H3968-HG	HM3068	MS3064	24,8	320	340	400	144	45	57	Tr340X5	M6	3,5	7
H3068-HG	HM3068	MS3064	30	320	340	400	187	45	57	Tr340X5	M6	3,5	7
H24068-HG	HM3068	MS3064	33,8	320	340	400	244	45	57	Tr340X5	M6	3,5	7
H3168-HG	HM3168	MS3168	50,1	320	340	440	254	55	70	Tr340X5	M6	3,5	7
H3268-HG	HM3168	MS3168	55,4	320	340	440	288	55	70	Tr340X5	M6	3,5	7
H24168-HG	HM3168	MS3168	53	320	340	440	317	55	70	Tr340X5	M6	3,5	7
H3368-HG	HM3168	MS3168	63,6	320	340	440	336	55	70	Tr340X5	M6	3,5	7
H3972-HG	HM3072	MS3072	25,9	340	360	420	144	45	57	Tr360X5	M6	3,5	7
H3072-HG	HM3072	MS3072	31,6	340	360	420	188	45	57	Tr360X5	M6	3,5	7
H24072-HG	HM3072	MS3072	35,5	340	360	420	244	45	57	Tr360X5	M6	3,5	7
H3172-HG	HM3172	MS3168	54,3	340	360	460	259	58	73	Tr360X5	M6	3,5	7
H3272-HG	HM3172	MS3168	61	340	360	460	299	58	73	Tr360X5	M6	3,5	7
H24172-HG	HM3172	MS3168	57,1	340	360	460	321	58	73	Tr360X5	M6	3,5	7
H3372-HG	HM3172	MS3168	71,8	340	360	460	357	58	73	Tr360X5	M6	3,5	7
H3976-HG	HM3076	MS3076	32,1	360	380	450	164	48	62	Tr380X5	M6	3,5	7
H3076-HG	HM3076	MS3076	36,2	360	380	450	193	48	62	Tr380X5	M6	3,5	7
H24076-HG	HM3076	MS3076	40,1	360	380	450	248	48	62	Tr380X5	M6	3,5	7
H3176-HG	HM3176	MS3176	62,4	360	380	490	264	60	75	Tr380X5	M6	3,5	7
H3276-HG	HM3176	MS3176	70,7	360	380	490	310	60	75	Tr380X5	M6	3,5	7
H24176-HG	HM3176	MS3176	64,9	360	380	490	323	60	75	Tr380X5	M6	3,5	7
H3376-HG	HM3176	MS3176	82,8	360	380	490	370	60	75	Tr380X5	M6	3,5	7
H3980-HG	HM3080	MS3076	35,4	380	400	470	168	52	66	Tr400X5	M6	3,5	7
H3080-HG	HM3080	MS3076	41,7	380	400	470	210	52	66	Tr400X5	M6	3,5	7
H24080-HG	HM3080	MS3076	46,4	380	400	470	272	52	66	Tr400X5	M6	3,5	7
H3180-HG	HM3180	MS3180	71,3	380	400	520	272	62	81	Tr400X5	M6	3,5	7
H3280-HG	HM3180	MS3180	82,1	380	400	520	328	62	81	Tr400X5	M6	3,5	7
H24180-HG	HM3180	MS3180	73,8	380	400	520	332	62	81	Tr400X5	M6	3,5	7
H3380-HG	HM3180	MS3180	93,4	380	400	520	380	62	81	Tr400X5	M6	3,5	7
H3984-HG	HM3084	MS3084	36,9	400	420	490	168	52	66	Tr420X5	M6	3,5	7
H3084X-HG	HM3084	MS3084	43,8	400	420	490	212	52	66	Tr420X5	M6	3,5	7
H24084-HG	HM3084	MS3084	48,6	400	420	490	274	52	66	Tr420X5	M6	3,5	7
H3184-HG	HM3184	MS3180	85,1	400	420	540	304	70	89	Tr420X5	M6	3,5	7
H3284-HG	HM3184	MS3180	95,3	400	420	540	352	70	89	Tr420X5	M6	3,5	7
H24184-HG	HM3184	MS3180	87,8	400	420	540	372	70	89	Tr420X5	M6	3,5	7
H3384-HG	HM3184	MS3180	105	400	420	540	395	70	89	Tr420X5	M6	3,5	7

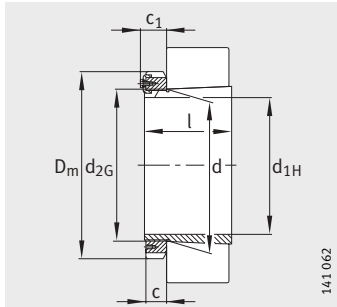

Taper 1:12
(taper 1:30 for H240, H241)

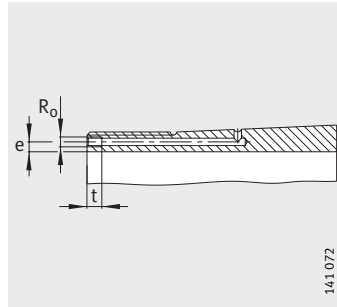

Hydraulic adapter sleeve
Mounting dimensions

Dimension table (continued) · Dimensions in mm													
Designation			Mass m ≈kg	Dimensions							Mounting dimensions		
Adapter sleeve Complete	Nut	Retainer		d _{1H}	d	D _m	l	c ≈	c ₁ ≈	d _{2G}	R ₀	e	t
H3988-HG	HM3088	MS3088	59	410	440	520	189	60	75	Tr440X5	M8	6,5	12
H3088-HG	HM3088	MS3088	67,7	410	440	520	228	60	75	Tr440X5	M8	6,5	12
H24088-HG	HM3088	MS3088	76,4	410	440	520	294	60	75	Tr440X5	M8	6,5	12
H3188-HG	HM3188	MS3188	105	410	440	560	307	70	89	Tr440X5	M8	6,5	12
H3288-HG	HM3188	MS3188	120	410	440	560	361	70	89	Tr440X5	M8	6,5	12
H24188-HG	HM3188	MS3188	111	410	440	560	372	70	89	Tr440X5	M8	6,5	12
H3388-HG	HM3188	MS3188	140	410	440	560	426	70	89	Tr440X5	M8	6,5	12
H3992-HG	HM3092	MS3088	61,4	430	460	540	189	60	75	Tr460X5	M8	6,5	12
H3092-HG	HM3092	MS3088	71,8	430	460	540	234	60	75	Tr460X5	M8	6,5	12
H24092-HG	HM3092	MS3088	80,8	430	460	540	300	60	75	Tr460X5	M8	6,5	12
H3192-HG	HM3192	MS3188	118	430	460	580	326	75	94	Tr460X5	M8	6,5	12
H3292-HG	HM3192	MS3188	134	430	460	580	382	75	94	Tr460X5	M8	6,5	12
H24192-HG	HM3192	MS3188	124	430	460	580	398	75	94	Tr460X5	M8	6,5	12
H3392-HG	HM3192	MS3188	157	430	460	580	451	75	94	Tr460X5	M8	6,5	12
H3996-HG	HM3096	MS3096	66,8	450	480	560	200	60	75	Tr480X5	M8	6,5	12
H3096-HG	HM3096	MS3096	75,9	450	480	560	237	60	75	Tr480X5	M8	6,5	12
H24096-HG	HM3096	MS3096	84,7	450	480	560	301	60	75	Tr480X5	M8	6,5	12
H3196-HG	HM3196	MS3196	135	450	480	620	335	75	94	Tr480X5	M8	6,5	12
H3296-HG	HM3196	MS3196	155	450	480	620	397	75	94	Tr480X5	M8	6,5	12
H24196-HG	HM3196	MS3196	142	450	480	620	408	75	94	Tr480X5	M8	6,5	12
H3396-HG	HM3196	MS3196	177	450	480	620	462	75	94	Tr480X5	M8	6,5	12
H39/500-HG	HM30/500	MS3096	75,2	470	500	580	208	68	83	Tr500X5	M8	6,5	12
H30/500-HG	HM30/500	MS3096	85,2	470	500	580	247	68	83	Tr500X5	M8	6,5	12
H240/500-HG	HM30/500	MS3096	93,8	470	500	580	309	68	83	Tr500X5	M8	6,5	12
H31/500-HG	HM31/500	MS31/500	145	470	500	630	356	80	99	Tr500X5	M8	6,5	12
H32/500-HG	HM31/500	MS31/500	170	470	500	630	428	80	99	Tr500X5	M8	6,5	12
H241/500-HG	HM31/500	MS31/500	151	470	500	630	430	80	99	Tr500X5	M8	6,5	12
H33/500-HG	HM31/500	MS31/500	189	470	500	630	480	80	99	Tr500X5	M8	6,5	12
H39/530-HG	HM30/530	MS30/530	89	500	530	630	216	68	89	Tr530X6	M8	6	12
H30/530-HG	HM30/530	MS30/530	103	500	530	630	265	68	89	Tr530X6	M8	6	12
H240/530-HG	HM30/530	MS30/530	115	500	530	630	343	68	89	Tr530X6	M8	6	12
H31/530-HG	HM31/530	MS31/530	161	500	530	670	364	80	102	Tr530X6	M8	6	12
H241/530-HG	HM31/530	MS31/530	167	500	530	670	440	80	102	Tr530X6	M8	6	12
H32/530-HG	HM31/530	MS31/530	192	500	530	670	447	80	102	Tr530X6	M8	6	12
H33/530-HG	HM31/530	MS31/530	215	500	530	670	504	80	102	Tr530X5	M8	6	12



Adapter sleeves

With nut and retainer

Dimension table (continued) - Dimensions in mm														
Designation			Mass m ≈kg	Dimensions								Mounting dimensions		
Adapter sleeve Complete	Nut	Retainer		d _{1H}	d	D _m	l	c ≈	c ₁ ≈	d _{2G}	R ₀	e	t	
H39/560-HG	HM30/560	MS30/560	95,6	530	560	650	227	75	96	Tr560X6	M8	6	12	
H30/560-HG	HM30/560	MS30/560	112	530	560	650	282	75	96	Tr560X6	M8	6	12	
H240/560-HG	HM30/560	MS30/560	124	530	560	650	358	75	96	Tr560X6	M8	6	12	
H31/560-HG	HM31/560	MS31/560	184	530	560	710	377	85	107	Tr560X6	M8	6	12	
H32/560-HG	HM31/560	MS31/560	218	530	560	710	462	85	107	Tr560X6	M8	6	12	
H241/560-HG	HM31/560	MS31/560	195	530	560	710	468	85	107	Tr560X6	M8	6	12	
H33/560-HG	HM31/560	MS31/560	250	530	560	710	535	85	107	Tr560X6	M8	6	12	
H39/600-HG	HM30/600	MS30/530	129	560	600	700	239	75	96	Tr600X6	G1/8	8	12	
H30/600-HG	HM30/600	MS30/530	149	560	600	700	289	75	96	Tr600X6	G1/8	8	12	
H240/600-HG	HM30/600	MS30/530	171	560	600	700	377	75	96	Tr600X6	G1/8	8	12	
H31/600-HG	HM31/600	MS31/560	234	560	600	750	399	85	107	Tr600X6	G1/8	8	12	
H32/600-HG	HM31/600	MS31/560	279	560	600	750	487	85	107	Tr600X6	G1/8	8	12	
H241/600-HG	HM31/600	MS31/560	249	560	600	750	490	85	107	Tr600X6	G1/8	8	12	
H33/600-HG	HM31/600	MS31/560	320	560	600	750	561	85	107	Tr600X6	G1/8	8	12	
H39/630-HG	HM30/630	MS30/630	123	600	630	730	254	75	96	Tr630X6	M8	6	12	
H30/630-HG	HM30/630	MS30/630	139	600	630	730	301	75	96	Tr630X6	M8	6	12	
H240/630-HG	HM30/630	MS30/630	157	600	630	730	395	75	96	Tr630X6	M8	6	12	
H31/630-HG	HM31/630	MS31/630	251	600	630	800	424	95	117	Tr630X6	M8	6	12	
H32/630-HG	HM31/630	MS31/630	297	600	630	800	521	95	117	Tr630X6	M8	6	12	
H241/630-HG	HM31/630	MS31/630	263	600	630	800	525	95	117	Tr630X6	M8	6	12	
H33/630-HG	HM31/630	MS31/630	338	600	630	800	597	95	117	Tr630X6	M8	6	12	
H39/670-HG	HM30/670	MS30/670	166	630	670	780	264	80	101	Tr670X6	G1/8	8	12	
H30/670-HG	HM30/670	MS30/670	194	630	670	780	324	80	101	Tr670X6	G1/8	8	12	
H240/670-HG	HM30/670	MS30/670	218	630	670	780	418	80	101	Tr670X6	G1/8	8	12	
H31/670-HG	HM31/670	MS31/670	341	630	670	850	456	106	128	Tr670X6	G1/8	8	12	
H241/670-HG	HM31/670	MS31/670	355	630	670	850	548	106	128	Tr670X6	G1/8	8	12	
H32/670-HG	HM31/670	MS31/670	402	630	670	850	558	106	128	Tr670X6	G1/8	8	12	
H33/670-HG	HM31/670	MS31/670	453	630	670	850	635	106	128	Tr670X6	G1/8	8	12	
H39/710-HG	HM30/710	MS30/710	200	670	710	830	286	90	111	Tr710X7	G1/8	8	12	
H30/710-HG	HM30/710	MS30/710	228	670	710	830	342	90	111	Tr710X7	G1/8	8	12	
H240/710-HG	HM30/710	MS30/710	254	670	710	830	438	90	111	Tr710X7	G1/8	8	12	
H31/710-HG	HM31/710	MS31/710	376	670	710	900	467	106	131	Tr710X7	G1/8	8	12	
H32/710-HG	HM31/710	MS31/710	444	670	710	900	572	106	131	Tr710X7	G1/8	8	12	
H241/710-HG	HM31/710	MS31/710	397	670	710	900	577	106	131	Tr710X7	G1/8	8	12	
H33/710-HG	HM31/710	MS31/710	501	670	710	900	652	106	131	Tr710X7	G1/8	8	12	

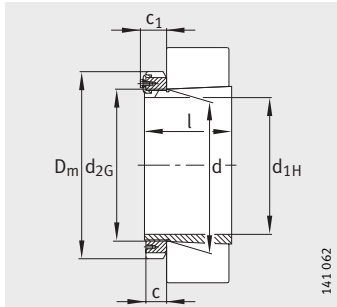

Taper 1:12
(taper 1:30 for H240, H241)

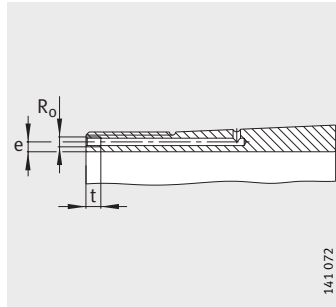

Hydraulic adapter sleeve
Mounting dimensions

Dimension table (continued) · Dimensions in mm													
Designation			Mass m ≈kg	Dimensions							Mounting dimensions		
Adapter sleeve Complete	Nut	Retainer		d _{1H}	d	D _m	l	c	c ₁	d _{2G}	R ₀	e	t
H39/750-HG	HM30/750	MS30/750	213	710	750	870	291	90	111	Tr750X7	G1/8	8	12
H30/750-HG	HM30/750	MS30/750	248	710	750	870	356	90	111	Tr750X7	G1/8	8	12
H240/750-HG	HM30/750	MS30/750	278	710	750	870	460	90	111	Tr750X7	G1/8	8	12
H31/750-HG	HM31/750	MS31/750	432	710	750	950	493	112	137	Tr750X7	G1/8	8	12
H32/750-HG	HM31/750	MS31/750	508	710	750	950	603	112	137	Tr750X7	G1/8	8	12
H241/750-HG	HM31/750	MS31/750	461	710	750	950	622	112	137	Tr750X7	G1/8	8	12
H33/750-HG	HM31/750	MS31/750	574	710	750	950	688	112	137	Tr750X7	G1/8	8	12
H39/800-HG	HM30/800	MS30/750	263	750	800	920	303	90	111	Tr800X7	G1/8	10	12
H30/800-HG	HM30/800	MS30/750	305	750	800	920	366	90	111	Tr800X7	G1/8	10	12
H240/800-HG	HM30/800	MS30/750	349	750	800	920	475	90	111	Tr800X7	G1/8	10	12
H31/800-HG	HM31/800	MS31/750	515	750	800	1000	505	112	137	Tr800X7	G1/8	10	12
H32/800-HG	HM31/800	MS31/750	611	750	800	1000	618	112	137	Tr800X7	G1/8	10	12
H241/800-HG	HM31/800	MS31/750	552	750	800	1000	627	112	137	Tr800X7	G1/8	10	12
H33/800-HG	HM31/800	MS31/750	716	750	800	1000	730	112	137	Tr800X7	G1/8	10	12
H39/850-HG	HM30/850	MS30/850	292	800	850	980	308	90	115	Tr850X7	G1/8	10	12
H30/850-HG	HM30/850	MS30/850	344	800	850	980	380	90	115	Tr850X7	G1/8	10	12
H240/850-HG	HM30/850	MS30/850	393	800	850	980	495	90	115	Tr850X7	G1/8	10	12
H31/850-HG	HM31/850	MS31/850	590	800	850	1060	536	118	143	Tr850X7	G1/8	10	12
H32/850-HG	HM31/850	MS31/850	696	800	850	1060	651	118	143	Tr850X7	G1/8	10	12
H241/850-HG	HM31/850	MS31/850	624	800	850	1060	658	118	143	Tr850X7	G1/8	10	12
H33/850-HG	HM31/850	MS31/850	814	800	850	1060	766	118	143	Tr850X7	G1/8	10	12
H39/900-HG	HM30/900	MS30/850	335	850	900	1030	326	100	112	Tr900X7	G1/8	10	12
H30/900-HG	HM30/900	MS30/850	392	850	900	1030	400	100	112	Tr900X7	G1/8	10	12
H240/900-HG	HM30/900	MS30/850	446	850	900	1030	520	100	112	Tr900X7	G1/8	10	12
H31/900-HG	HM31/900	MS31/900	674	850	900	1120	557	125	150	Tr900X7	G1/8	10	12
H32/900-HG	HM31/900	MS31/900	775	850	900	1120	660	125	150	Tr900X7	G1/8	10	12
H241/900-HG	HM31/900	MS31/900	712	850	900	1120	685	125	150	Tr900X7	G1/8	10	12
H33/900-HG	HM31/900	MS31/900	923	850	900	1120	795	125	150	Tr900X7	G1/8	10	12
H39/950-HG	HM30/950	MS30/950	369	900	950	1080	344	100	122	Tr950X8	G1/8	10	12
H30/950-HG	HM30/950	MS30/950	432	900	950	1080	420	100	122	Tr950X8	G1/8	10	12
H240/950-HG	HM30/950	MS30/950	499	900	950	1080	557	100	122	Tr950X8	G1/8	10	12
H31/950-HG	HM31/950	MS31/950	738	900	950	1170	583	125	150	Tr950X8	G1/8	10	12
H32/950-HG	HM31/950	MS31/950	835	900	950	1170	675	125	150	Tr950X8	G1/8	10	12
H241/950-HG	HM31/950	MS31/950	776	900	950	1170	715	125	150	Tr950X8	G1/8	10	12
H33/950-HG	HM31/950	MS31/950	1000	900	950	1170	815	125	150	Tr950X8	G1/8	10	12



Adapter sleeves

With nut and retainer

Dimension table (continued) - Dimensions in mm														
Designation			Mass m ≈kg	Dimensions								Mounting dimensions		
Adapter sleeve Complete	Nut	Retainer		d _{1H}	d	D _m	l	c ≈	c ₁ ≈	d _{2G}	R ₀	e	t	
H39/1000-HG	HM30/1000	MS30/1000	410	950	1 000	1 140	358	100	122	Tr1000X8	G1/8	10	12	
H30/1000-HG	HM30/1000	MS30/1000	474	950	1 000	1 140	430	100	122	Tr1000X8	G1/8	10	12	
H240/1000-HG	HM30/1000	MS30/1000	539	950	1 000	1 140	562	100	122	Tr1000X8	G1/8	10	12	
H31/1000-HG	HM31/1000	MS31/1000	840	950	1 000	1 240	609	125	150	Tr1000X8	G1/8	10	12	
H32/1000-HG	HM31/1000	MS31/1000	952	950	1 000	1 240	707	125	150	Tr1000X8	G1/8	10	12	
H241/1000-HG	HM31/1000	MS31/1000	886	950	1 000	1 240	755	125	150	Tr1000X8	G1/8	10	12	
H33/1000-HG	HM31/1000	MS31/1000	1 144	950	1 000	1 240	857	125	150	Tr1000X8	G1/8	10	12	
H39/1060-HG	HM30/1060	MS30/1000	493	1 000	1 060	1 200	372	100	122	Tr1060X8	G1/4	12	15	
H30/1060-HG	HM30/1060	MS30/1000	574	1 000	1 060	1 200	447	100	122	Tr1060X8	G1/4	12	15	
H240/1060-HG	HM30/1060	MS30/1000	665	1 000	1 060	1 200	588	100	122	Tr1060X8	G1/4	12	15	
H31/1060-HG	HM31/1060	MS31/1000	985	1 000	1 060	1 300	622	125	150	Tr1060X8	G1/4	12	15	
H241/1060-HG	HM31/1060	MS31/1000	1 056	1 000	1 060	1 300	775	125	150	Tr1060X8	G1/4	12	15	
H39/1120-HG	HM30/1120	MS30/1000	521	1 060	1 120	1 260	372	100	122	Tr1120X8	G1/4	12	15	
H30/1120-HG	HM30/1120	MS30/1000	631	1 060	1 120	1 260	467	100	122	Tr1120X8	G1/4	12	15	
H240/1120-HG	HM30/1120	MS30/1000	728	1 060	1 120	1 260	612	100	122	Tr1120X8	G1/4	12	15	
H31/1120-HG	HM31/1120	MS31/1000	1 060	1 060	1 120	1 360	622	125	150	Tr1120X8	G1/4	12	15	
H241/1120-HG	HM31/1120	MS31/1000	1 168	1 060	1 120	1 360	805	125	150	Tr1120X8	G1/4	13	15	
H39/1180-HG	HM30/1180	MS30/1000	576	1 120	1 180	1 320	394	100	122	Tr1180X8	G1/4	12	15	
H30/1180-HG	HM30/1180	MS30/1000	682	1 120	1 180	1 320	479	100	122	Tr1180X8	G1/4	12	15	
H240/1180-HG	HM30/1180	MS30/1000	782	1 120	1 180	1 320	625	100	122	Tr1180X8	G1/4	12	15	
H31/1180-HG	HM31/1180	MS31/1000	1 163	1 120	1 180	1 420	647	125	150	Tr1180X8	G1/4	12	15	
H241/1180-HG	HM31/1180	MS31/1000	1 287	1 120	1 180	1 420	845	125	150	Tr1180X8	G1/4	13	15	
H39/1250-HG	HM30/1250	MS30/1000	708	1 180	1 250	1 390	407	110	132	Tr1250X8	G1/4	14	15	
H30/1250-HG	HM30/1250	MS30/1000	858	1 180	1 250	1 390	509	110	132	Tr1250X8	G1/4	15	15	
H240/1250-HG	HM30/1250	MS30/1000	988	1 180	1 250	1 390	660	110	132	Tr1250X8	G1/4	14	15	
H31/1250-HG	HM31/1250	MS31/1000	1 377	1 180	1 250	1 490	677	125	150	Tr1250X8	G1/4	14	15	
H241/1250-HG	HM31/1250	MS31/1000	1 542	1 180	1 250	1 490	885	125	150	Tr1250X8	G1/4	14	15	
H39/1320-HG	HM30/1320	MS30/1000	781	1 250	1 320	1 460	430	110	132	Tr1320X8	G1/4	14	15	
H30/1320-HG	HM30/1320	MS30/1000	946	1 250	1 320	1 460	534	110	132	Tr1320X8	G1/4	15	15	
H240/1320-HG	HM30/1320	MS30/1000	1 085	1 250	1 320	1 460	690	110	132	Tr1320X8	G1/4	14	15	
H31/1320-HG	HM31/1320	MS31/1000	1 515	1 250	1 320	1 560	710	125	150	Tr1320X8	G1/4	14	15	
H241/1320-HG	HM31/1320	MS31/1000	1 703	1 250	1 320	1 560	935	125	150	Tr1320X8	G1/4	14	15	

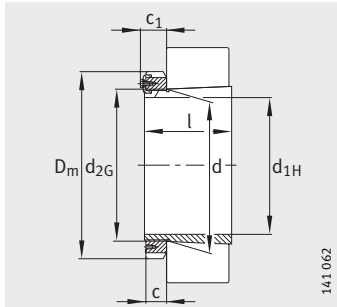

Taper 1:12
(taper 1:30 for H240, H241)

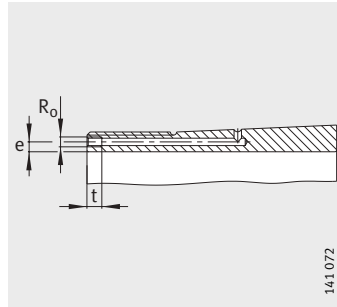

Hydraulic adapter sleeve
Mounting dimensions

Dimension table (continued) · Dimensions in mm														
Designation			Mass m ≈ kg	Dimensions								Mounting dimensions		
Adapter sleeve Complete	Nut	Retainer		d _{1H}	d	D _m	l	c	c ₁	d _{2G}	R ₀	e	t	
H39/1400-HG	HM30/1400	MS30/1000	924	1 320	1 400	1 540	445	110	132	Tr1400X8	G1/4	15	15	
H30/1400-HG	HM30/1400	MS30/1000	1 113	1 320	1 400	1 540	546	110	132	Tr1400X8	G1/4	15	15	
H240/1400-HG	HM30/1400	MS30/1000	1 287	1 320	1 400	1 540	705	110	132	Tr1400X8	G1/4	14	15	
H31/1400-HG	HM31/1400	MS31/1000	1 792	1 320	1 400	1 640	735	130	155	Tr1400X8	G1/4	15	15	
H241/1400-HG	HM31/1400	MS31/1000	2 030	1 320	1 400	1 640	965	130	155	Tr1400X8	G1/4	15	15	
H39/1500-HG	HM30/1500	MS30/1500	1 210	1 400	1 500	1 650	465	110	132	Tr1500X8	G1/4	15	15	
H30/1500-HG	HM30/1500	MS30/1500	1 534	1 400	1 500	1 650	600	110	132	Tr1500X8	G1/4	15	15	
H240/1500-HG	HM30/1500	MS30/1500	1 791	1 400	1 500	1 650	775	110	132	Tr1500X8	G1/4	14	15	
H31/1500-HG	HM31/1500	MS31/1000	2 227	1 400	1 500	1 740	755	130	155	Tr1500X8	G1/4	15	15	
H241/1500-HG	HM31/1500	MS31/1000	2 564	1 400	1 500	1 740	990	130	155	Tr1500X8	G1/4	15	15	
H39/1600-HG	MU-195077A	MS30/850	2 481	1 500	1 600	1 730	465	100	112	Tr1600X8	G1/4	15	15	
H39/1700-HG	MU-195,078A	MS30/850	2 619	1 600	1 700	1 830	475	100	112	Tr1700X8	G1/4	15	15	



Extraction sleeves

Dimension table · Dimensions in mm							
Designation	Mass m ≈kg	Dimensions					
		d _{1H}	d	l	a ≈	b	d _{2G}
AH208	0,08	35	40	25	2	6	M45X1,5
AH308	0,09	35	40	29	3	6	M45X1,5
AH2308	0,13	35	40	40	3	7	M45X1,5
AH3308	0,15	35	40	44	3	7	M45X1,5
AH209	0,09	40	45	26	3	6	M50X1,5
AH309	0,11	40	45	31	3	6	M50X1,5
AH2309	0,17	40	45	44	3	7	M50X1,5
AH3309	0,18	40	45	47	3	7	M50X1,5
AH210	0,12	45	50	28	3	7	M55X2
AHX310	0,14	45	50	35	3	7	M55X2
AHX2310	0,22	45	50	50	3	9	M55X2
AH3310	0,24	45	50	54	3	9	M55X2
AH211	0,13	50	55	29	3	7	M60X2
AHX311	0,17	50	55	37	3	7	M60X2
AHX2311	0,26	50	55	54	3	10	M60X2
AH3311	0,3	50	55	60	3	10	M60X2
AH212	0,16	55	60	32	3	8	M65X2
AHX312	0,2	55	60	40	3	8	M65X2
AHX2312	0,32	55	60	58	3	11	M65X2
AH3312	0,41	55	60	65	3	11	M70X2
AH213	0,21	60	65	32,5	3,5	8	M75X2
AH213G	0,18	60	65	32,5	3,5	8	M70X2
AH313	0,27	60	65	42	3	8	M75X2
AH313G	0,23	60	65	42	3	8	M70X2
AH2313	0,42	60	65	61	3	12	M75X2
AH2313G	0,36	60	65	61	3	12	M70X2
AH3313	0,49	60	65	71	3	12	M75X2
AH214	0,23	65	70	33,5	3,5	8	M80X2
AH214G	0,2	65	70	33,5	3,5	8	M75X2
AH314	0,29	65	70	43	4	8	M80X2
AH314G	0,26	65	70	43	4	8	M75X2
AHX2314	0,47	65	70	64	4	12	M80X2
AHX2314G	0,42	65	70	64	4	12	M75X2
AH3314	0,57	65	70	76	4	12	M80X2
AH215	0,26	70	75	34,5	3,5	8	M85X2
AH215G	0,22	70	75	34,5	3,5	8	M80X2
AH315	0,33	70	75	45	4	8	M85X2
AH315G	0,29	70	75	45	4	8	M80X2

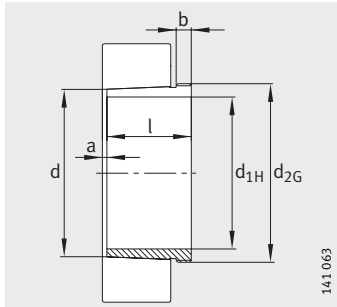

Taper 1:12

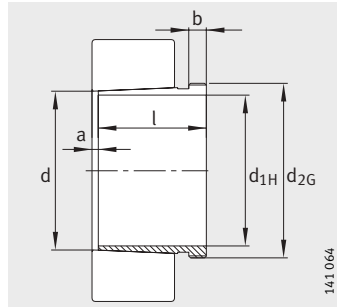

AH240, AH241
Taper 1:30

Dimension table (continued) · Dimensions in mm							
Designation	Mass m ≈kg	Dimensions					
		d _{1H}	d	l	a ≈	b	d _{2G}
AHX2315	0,54	70	75	68	4	12	M85X2
AHX2315G	0,48	70	75	68	4	12	M80X2
AH3315	0,66	70	75	81	4	12	M85X2
AH216	0,28	75	80	35,5	3,5	8	M90X2
AH316	0,38	75	80	48	4	8	M90X2
AHX2316	0,61	75	80	71	4	12	M90X2
AH3316	0,71	75	80	81	4	12	M90X2
AH217	0,33	80	85	38,5	3,5	9	M95X2
AHX317	0,44	80	85	52	4	9	M95X2
AH3217	0,52	80	85	60	4	10	M95X2
AHX2317	0,68	80	85	74	4	13	M95X2
AH3317	0,81	80	85	86	4	13	M95X2
AH218	0,36	85	90	40	4	9	M100X2
AHX318	0,48	85	90	53	4	9	M100X2
AHX3218	0,58	85	90	63	4	10	M100X2
AHX2318	0,78	85	90	79	4	14	M100X2
AH3318	0,88	85	90	87	4	14	M100X2
AH219	0,42	90	95	43	4	10	M105X2
AHX319	0,55	90	95	57	4	10	M105X2
AHX3219	0,67	90	95	67	4	11	M105X2
AHX2319	0,91	90	95	85	4	16	M105X2
AH3319	1,03	90	95	94	4	16	M105X2
AH220	0,46	95	100	45	4	10	M110X2
AHX320	0,6	95	100	59	4	10	M110X2
AH24020	0,5	95	100	62	9	12	M105X2
AHX3120	0,67	95	100	64	4	11	M110X2
AHX3220	0,78	95	100	73	4	11	M110X2
AH24120	0,63	95	100	78	9	13	M105X2
AHX2320	1,03	95	100	90	4	16	M110X2
AH3320	1,16	95	100	99	4	16	M110X2
AH222	0,57	105	110	50	4	11	M120X2
AHX322	0,73	105	110	63	4	12	M120X2
AHX3122	0,79	105	110	68	4	11	M120X2
AH24022	0,65	105	110	73	9	13	M115X2
AH24122	0,73	105	110	82	9	13	M115X2
AHX3222A	0,98	105	110	82	4	11	M120X2
AHX2322	1,38	105	110	98	4	16	M125X2
AHX2322G	1,26	105	110	98	4	16	M120X2



Extraction sleeves

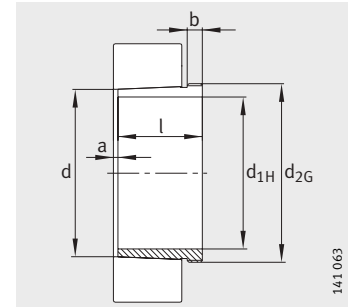

Taper 1:12

Dimension table (continued) · Dimensions in mm							
Designation	Mass m ≈kg	Dimensions					
		d _{1H}	d	l	a ≈	b	d _{2G}
AH3322	1,54	105	110	108	4	16	M125X2
AH224	0,67	115	120	53	4	12	M130X2
AHX3024	0,77	115	120	60	4	13	M130X2
AHX324	0,89	115	120	69	4	13	M130X2
AH24024	0,71	115	120	73	9	13	M125X2
AHX3124	0,97	115	120	75	4	12	M130X2
AHX3224A	1,22	115	120	90	4	13	M130X2
AH24124	1,02	115	120	93	9	13	M130X2
AHX2324	1,64	115	120	105	4	17	M135X2
AHX2324G	1,5	115	120	105	4	17	M130X2
AH3324	1,99	115	120	123	4	17	M135X2
AH226	0,72	125	130	53	4	12	M140X2
AHX3026	0,94	125	130	67	4	14	M140X2
AHX326	1,05	125	130	74	4	14	M140X2
AHX3126	1,1	125	130	78	4	12	M140X2
AH24026	0,89	125	130	83	10	14	M135X2
AH24126	1,13	125	130	94	10	14	M140X2
AHX3226	1,61	125	130	98	4	15	M145X2
AHX3226G	1,48	125	130	98	4	15	M140X2
AHX2326	2	125	130	115	4	19	M145X2
AHX2326G	1,84	125	130	115	4	19	M140X2
AH3326	2,36	125	130	131	4	19	M145X2
AH228	0,83	135	140	56	5	13	M150X2
AHX3028	1,03	135	140	68	5	14	M150X2
AHX328	1,18	135	140	77	5	14	M150X2
AH24028	0,96	135	140	83	10	14	M145X2
AHX3128	1,29	135	140	83	5	14	M150X2
AH24128	1,29	135	140	99	10	14	M150X2
AHX3228	1,86	135	140	104	5	15	M155X3
AHX3228G	1,72	135	140	104	5	15	M150X2
AHX2328	2,4	135	140	125	5	20	M155X3
AHX2328G	2,21	135	140	125	5	20	M150X2
AH3328	2,72	135	140	138	5	20	M155X3
AH230	0,97	145	150	60	5	14	M160X3
AHX3030	1,18	145	150	72	5	15	M160X3
AHX330	1,54	145	150	83	5	15	M165X3
AHX330G	1,39	145	150	83	5	15	M160X3
AH24030	1,12	145	150	90	11	15	M155X3

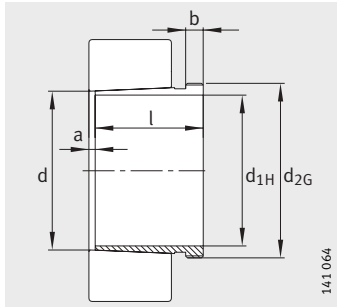

AH240, AH241
Taper 1:30

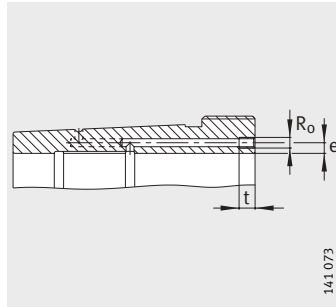

Hydraulic extraction sleeve
(suffix H)
Mounting dimensions

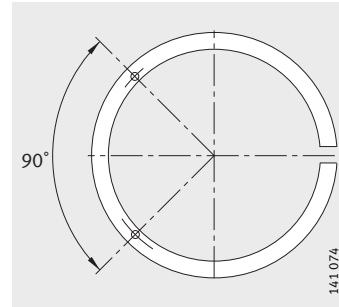

Pump connectors for
hydraulic extraction sleeve

Dimension table (continued) · Dimensions in mm										
Designation	Mass m ≈ kg	Dimensions						Mounting dimensions		
		d _{1H}	d	l	a ≈	b	d _{2G}	R ₀	e	t
AHX3130	1,81	145	150	96	5	15	M165X3	-	-	-
AHX3130G	1,66	145	150	96	5	15	M160X3	-	-	-
AHX3230	2,25	145	150	114	5	17	M165X3	-	-	-
AHX3230G	2,09	145	150	114	5	17	M160X3	-	-	-
AH24130	1,63	145	150	115	11	15	M160X3	-	-	-
AHX2330	2,88	145	150	135	5	24	M165X3	-	-	-
AHX2330G	2,64	145	150	135	5	24	M160X3	-	-	-
AH3330	3,36	145	150	152	5	24	M165X3	-	-	-
AH232	1,71	150	160	64	5	15	M170X3	-	-	-
AH3032	2,09	150	160	77	5	16	M170X3	-	-	-
AH3032-H	2,09	150	160	77	5	16	M170X3	M6	4,2	7
AH332	2,76	150	160	88	5	16	M180X3	-	-	-
AH332G	2,42	150	160	88	5	16	M170X3	-	-	-
AH24032	2,31	150	160	95	11	15	M170X3	-	-	-
AH3132A	2,9	150	160	103	5	16	M170X3	-	-	-
AH3132A-H	2,9	150	160	103	5	16	M170X3	M6	4,5	7
AH24132	3,04	150	160	124	11	15	M170X3	-	-	-
AH3232	4,08	150	160	124	6	20	M180X3	-	-	-
AH3232G	3,65	150	160	124	6	20	M170X3	-	-	-
AH3232G-H	3,65	150	160	124	6	20	M170X3	M6	4,5	7
AH3232-H	4,08	150	160	124	6	20	M180X3	M6	4,5	7
AH2332	4,77	150	160	140	6	24	M180X3	-	-	-
AH2332G	4,26	150	160	140	6	24	M170X3	-	-	-
AH2332G-H	4,26	150	160	140	6	24	M170X3	M6	4,5	7
AH2332-H	4,77	150	160	140	6	24	M180X3	M6	4,5	7
AH3332	5,58	150	160	160	6	24	M180X3	-	-	-
AH3332-H	5,58	150	160	160	6	24	M180X3	M6	4,5	7
AH3934A	1,65	160	170	59	5	13	M180X3	-	-	-
AH234	1,98	160	170	69	5	16	M180X3	-	-	-
AH3034	2,48	160	170	85	5	17	M180X3	-	-	-
AH3034-H	2,48	160	170	85	5	17	M180X3	M6	4,2	7
AH334	3,13	160	170	93	5	17	M190X3	-	-	-
AH334G	2,75	160	170	93	5	17	M180X3	-	-	-
AH3134A	3,12	160	170	104	5	16	M180X3	-	-	-
AH3134A-H	3,12	160	170	104	5	16	M180X3	M6	4,5	7
AH24034	2,76	160	170	106	11	16	M180X3	-	-	-
AH24134	3,27	160	170	125	11	16	M180X3	-	-	-
AH3234	4,83	160	170	134	6	24	M190X3	-	-	-



Extraction sleeves

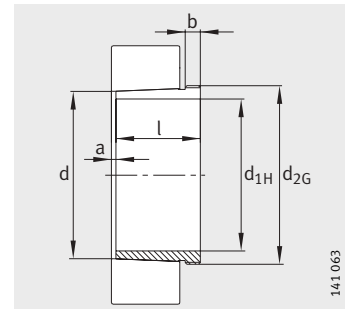

Taper 1:12

Dimension table (continued) · Dimensions in mm										
Designation	Mass m ≈kg	Dimensions						Mounting dimensions		
		d _{1H}	d	l	a ≈	b	d _{2G}	R ₀	e	t
AH3234G	4,29	160	170	134	6	24	M180X3	–	–	–
AH3234G-H	4,29	160	170	134	6	24	M180X3	M6	4,5	7
AH3234-H	4,83	160	170	134	6	24	M190X3	M6	4,5	7
AH2334	5,32	160	170	146	6	24	M190X3	–	–	–
AH2334G	4,78	160	170	146	6	24	M180X3	–	–	–
AH2334G-H	4,78	160	170	146	6	24	M180X3	M6	4,5	7
AH2334-H	5,32	160	170	146	6	24	M190X3	M6	4,5	7
AH3334	6,11	160	170	164	6	24	M190X3	–	–	–
AH3334-H	6,11	160	170	164	6	24	M190X3	M6	4,5	7
AH3936	1,96	170	180	66	5	13	M190X3	–	–	–
AH236	2,1	170	180	69	5	16	M190X3	–	–	–
AH3036	2,87	170	180	92	6	17	M190X3	–	–	–
AH3036-H	2,87	170	180	92	6	17	M190X3	M6	4,2	7
AH24036	3,21	170	180	116	11	16	M190X3	–	–	–
AH3136A	3,79	170	180	116	6	19	M190X3	–	–	–
AH3136A-H	3,79	170	180	116	6	19	M190X3	M6	4,5	7
AH24136	3,74	170	180	134	11	16	M190X3	–	–	–
AH3236	5,39	170	180	140	6	25	M200X3	–	–	–
AH3236G	4,8	170	180	140	6	25	M190X3	–	–	–
AH3236G-H	4,8	170	180	140	6	25	M190X3	M6	4,5	7
AH3236-H	5,39	170	180	140	6	25	M200X3	M6	4,5	7
AH2336	6,04	170	180	154	6	26	M200X3	–	–	–
AH2336G	5,42	170	180	154	6	26	M190X3	–	–	–
AH2336G-H	5,42	170	180	154	6	26	M190X3	M6	4,5	7
AH2336-H	6,04	170	180	154	6	26	M200X3	M6	4,5	7
AH3336	7,1	170	180	176	6	26	M200X3	–	–	–
AH3336-H	7,1	170	180	176	6	26	M200X3	M6	4,5	7
AH3938	2,07	180	190	66	5	13	M200X3	–	–	–
AH238	2,57	180	190	73	5	17	Tr205X4	–	–	–
AH238G	2,36	180	190	73	5	17	M200X3	–	–	–
AH3038	3,42	180	190	96	6	18	Tr205X4	–	–	–
AH3038G	3,19	180	190	96	6	18	M200X3	–	–	–
AH3038G-H	3,19	180	190	96	6	18	M200X3	M6	4,2	7
AH3038-H	3,42	180	190	96	6	18	Tr205X4	M6	4,2	7
AH24038	3,48	180	190	118	13	18	M200X3	–	–	–
AH3138	4,89	180	190	125	6	20	Tr210X4	–	–	–
AH3138G	4,39	180	190	125	6	20	M200X3	–	–	–
AH3138G-H	4,39	180	190	125	6	20	M200X3	M6	4,5	7

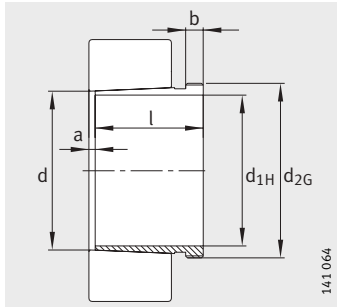

AH240, AH241
Taper 1:30

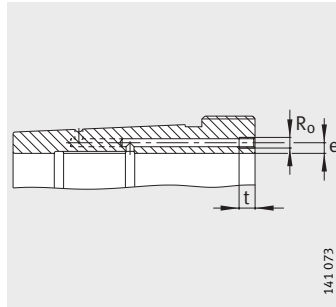

Hydraulic extraction sleeve
(suffix H)
Mounting dimensions

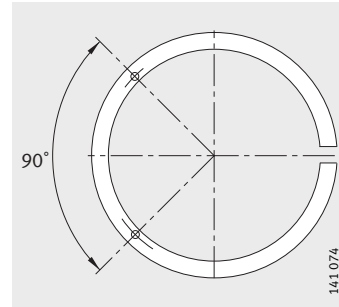

Pump connectors for
hydraulic extraction sleeve

Dimension table (continued) · Dimensions in mm										
Designation	Mass m ≈kg	Dimensions						Mounting dimensions		
		d _{1H}	d	l	a ≈	b	d _{2G}	R ₀	e	t
AH3138-H	4,89	180	190	125	6	20	Tr210X4	M6	4,5	7
AH3238	5,92	180	190	145	7	25	Tr210X4	-	-	-
AH3238G	5,3	180	190	145	7	25	M200X3	-	-	-
AH3238G-H	5,3	180	190	145	7	25	M200X3	M6	4,5	7
AH3238-H	5,92	180	190	145	7	25	Tr210X4	M6	4,5	7
AH24138	4,37	180	190	146	13	18	M200X3	-	-	-
AH2338	6,67	180	190	160	7	26	Tr210X4	-	-	-
AH2338G	6,02	180	190	160	7	26	M200X3	-	-	-
AH2338G-H	6,02	180	190	160	7	26	M200X3	M6	4,5	7
AH2338-H	6,67	180	190	160	7	26	Tr210X4	M6	4,5	7
AH3338	7,76	180	190	181	7	26	Tr210X4	-	-	-
AH3338-H	7,76	180	190	181	7	26	Tr210X4	M6	4,5	7
AH240	2,88	190	200	77	5	18	Tr215X4	-	-	-
AH240G	2,43	190	200	77	5	18	Tr210X4	-	-	-
AH3940	2,62	190	200	77	6	16	Tr210X4	-	-	-
AH3040	3,86	190	200	102	6	19	Tr215X4	-	-	-
AH3040G	3,62	190	200	102	6	19	Tr210X4	-	-	-
AH3040G-H	3,62	190	200	102	6	19	Tr210X4	M6	4,2	7
AH3040-H	3,86	190	200	102	6	19	Tr215X4	M6	4,2	7
AH24040	3,96	190	200	127	13	18	Tr210X4	-	-	-
AH3140	5,6	190	200	134	6	21	Tr220X4	-	-	-
AH3140-H	5,6	190	200	134	6	21	Tr220X4	M6	4,5	7
AH3240	6,61	190	200	153	7	24	Tr220X4	-	-	-
AH3240-H	6,61	190	200	153	7	24	Tr220X4	M6	4,5	7
AH24140	5,02	190	200	158	13	18	Tr210X4	-	-	-
AH2340	7,64	190	200	170	7	30	Tr220X4	-	-	-
AH2340-H	7,64	190	200	170	7	30	Tr220X4	M6	4,5	7
AH3340	9,04	190	200	195	7	30	Tr220X4	-	-	-
AH3340-H	9,04	190	200	195	7	30	Tr220X4	M6	4,5	7
AH3944	4,81	200	220	77	6	16	Tr230X4	-	-	-
AH3944-H	4,81	200	220	77	6	16	Tr230X4	M8	7,5	12
AH244	5,62	200	220	85	6	18	Tr235X4	-	-	-
AH244G	5,36	200	220	85	6	18	Tr230X4	-	-	-
AH3044	7,47	200	220	111	6	20	Tr235X4	-	-	-
AH3044G	7,18	200	220	111	6	20	Tr230X4	-	-	-
AH3044G-H	7,18	200	220	111	6	20	Tr230X4	G1/8	6,5	12
AH3044-H	7,47	200	220	111	6	20	Tr235X4	G1/8	8,5	12
AH24044	8,22	200	220	138	14	18	Tr230X4	-	-	-



Extraction sleeves

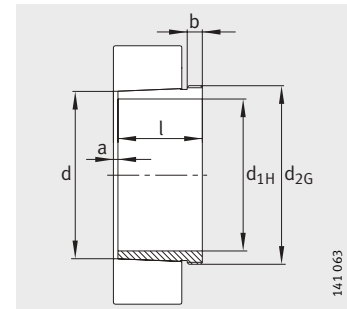

Taper 1:12

Dimension table (continued) · Dimensions in mm										
Designation	Mass m ≈kg	Dimensions						Mounting dimensions		
		d _{1H}	d	l	a ≈	b	d _{2G}	R ₀	e	t
AH24044-H	8,22	200	220	138	14	18	Tr230X4	M6	8	7
AH3144	10,4	200	220	145	6	23	Tr240X4	–	–	–
AH3144-H	10,4	200	220	145	6	23	Tr240X4	G1/8	8,5	12
AH24144	10,3	200	220	170	14	20	Tr230X4	–	–	–
AH24144-H	10,3	200	220	170	14	20	Tr230X4	M6	8	7
AH2344	13,6	200	220	181	8	30	Tr240X4	–	–	–
AH2344-H	13,6	200	220	181	8	30	Tr240X4	G1/8	8,5	12
AH3344	16,2	200	220	210	8	30	Tr240X4	–	–	–
AH3344-H	16,2	200	220	210	8	30	Tr240X4	G1/8	8,5	12
AH3948	5,26	220	240	77	6	16	Tr250X4	–	–	–
AH3948-H	5,26	220	240	77	6	16	Tr250X4	M8	7,5	12
AH248	7,41	220	240	96	6	22	Tr260X4	–	–	–
AH3048	8,92	220	240	116	7	21	Tr260X4	–	–	–
AH3048-H	8,92	220	240	116	7	21	Tr260X4	G1/8	8,5	12
AH24048	9,03	220	240	138	15	20	Tr250X4	–	–	–
AH24048-H	9,03	220	240	138	15	20	Tr250X4	M6	8	7
AH3148	12,3	220	240	154	7	25	Tr260X4	–	–	–
AH3148-H	12,3	220	240	154	7	25	Tr260X4	G1/8	8,5	12
AH24148	12,6	220	240	180	15	20	Tr260X4	–	–	–
AH24148-H	12,6	220	240	180	15	20	Tr260X4	G1/8	8,5	12
AH2348	15,6	220	240	189	8	30	Tr260X4	–	–	–
AH2348-H	15,6	220	240	189	8	30	Tr260X4	G1/8	8,5	12
AH3348	19,3	220	240	225	8	30	Tr260X4	–	–	–
AH3348-H	19,3	220	240	225	8	30	Tr260X4	G1/8	8,5	12
AH3952	7,39	240	260	94	6	18	Tr275X4	–	–	–
AH3952G	7,7	240	260	94	6	18	Tr280X4	–	–	–
AH3952G-H	7,7	240	260	94	6	18	Tr280X4	M8	7,5	12
AH3952-H	7,39	240	260	94	6	18	Tr275X4	M8	7,5	12
AH252	8,83	240	260	105	6	23	Tr280X4	–	–	–
AH3052	10,8	240	260	128	7	23	Tr280X4	–	–	–
AH3052-H	10,8	240	260	128	7	23	Tr280X4	G1/8	8,5	12
AH24052	11,6	240	260	162	16	20	Tr270X4	–	–	–
AH24052G	12,3	240	260	162	16	20	Tr280X4	–	–	–
AH24052G-H	12,3	240	260	162	16	20	Tr280X4	M6	8	7
AH24052-H	11,6	240	260	162	16	20	Tr270X4	M6	8	7
AH3152	16	240	260	172	7	26	Tr290X4	–	–	–
AH3152G	15,1	240	260	172	7	26	Tr280X4	–	–	–
AH3152G-H	15,1	240	260	172	7	26	Tr280X4	G1/8	7	12

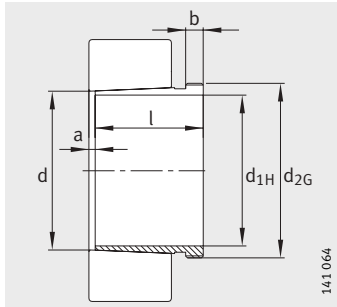

AH240, AH241
Taper 1:30

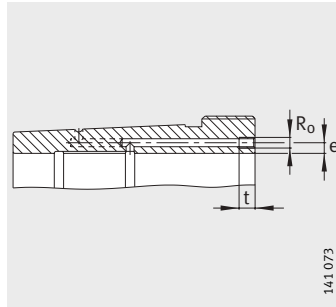

Hydraulic extraction sleeve
(suffix H)
Mounting dimensions

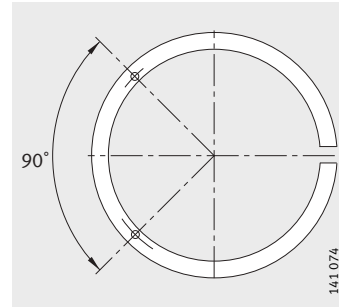

Pump connectors for
hydraulic extraction sleeve

Dimension table (continued) · Dimensions in mm										
Designation	Mass m ≈kg	Dimensions						Mounting dimensions		
		d _{1H}	d	l	a ≈	b	d _{2G}	R ₀	e	t
AH3152-H	16	240	260	172	7	26	Tr290X4	G1/8	7	12
AH24152	15,5	240	260	202	16	22	Tr280X4	–	–	–
AH24152-H	15,5	240	260	202	16	22	Tr280X4	G1/8	8,5	12
AH2352	19,7	240	260	205	8	30	Tr290X4	–	–	–
AH2352G	18,7	240	260	205	8	30	Tr280X4	–	–	–
AH2352G-H	18,7	240	260	205	8	30	Tr280X4	G1/8	8,5	12
AH2352-H	19,7	240	260	205	8	30	Tr290X4	G1/8	8,5	12
AH3352	23,2	240	260	236	8	30	Tr290X4	–	–	–
AH3352-H	23,2	240	260	236	8	30	Tr290X4	G1/8	8,5	12
AH3956	7,98	260	280	94	6	18	Tr295X4	–	–	–
AH3956G	8,3	260	280	94	6	18	Tr300X4	–	–	–
AH3956G-H	8,3	260	280	94	6	18	Tr300X4	M8	7,5	12
AH3956-H	7,98	260	280	94	6	18	Tr295X4	M8	7,5	12
AH256	9,52	260	280	105	8	23	Tr300X4	–	–	–
AH3056	12	260	280	131	8	24	Tr300X4	–	–	–
AH3056-H	12	260	280	131	8	24	Tr300X4	G1/8	8,5	12
AH24056	12,6	260	280	162	17	22	Tr290X4	–	–	–
AH24056G	13,4	260	280	162	17	22	Tr300X4	–	–	–
AH24056G-H	13,4	260	280	162	17	22	Tr300X4	M6	8	7
AH24056-H	12,6	260	280	162	17	22	Tr290X4	M6	8	7
AH3156	17,7	260	280	175	8	28	Tr310X4	–	–	–
AH3156G	16,7	260	280	175	8	28	Tr300X4	–	–	–
AH3156G-H	16,7	260	280	175	8	28	Tr300X4	G1/8	8,5	12
AH3156-H	17,7	260	280	175	8	28	Tr310X4	G1/8	8,5	12
AH24156	16,7	260	280	202	17	22	Tr300X4	–	–	–
AH24156-H	16,7	260	280	202	17	22	Tr300X4	G1/8	8,5	12
AH2356	22,1	260	280	212	8	30	Tr310X4	–	–	–
AH2356G	20,9	260	280	212	8	30	Tr300X4	–	–	–
AH2356G-H	20,9	260	280	212	8	30	Tr300X4	G1/8	8,5	12
AH2356-H	22,1	260	280	212	8	30	Tr310X4	G1/8	8,5	12
AH3356	27,4	260	280	254	8	30	Tr310X4	–	–	–
AH3356-H	27,4	260	280	254	8	30	Tr310X4	G1/8	8,5	12
AH3960	10,4	280	300	112	7	21	Tr315X5	–	–	–
AH3960G	10,8	280	300	112	7	21	Tr320X5	–	–	–
AH3960G-H	10,8	280	300	112	7	21	Tr320X5	M8	7,5	12
AH3960-H	10,4	280	300	112	7	21	Tr315X5	M8	7,5	12
AH3060	14,4	280	300	145	8	26	Tr320X5	–	–	–
AH3060-H	14,4	280	300	145	8	26	Tr320X5	G1/8	8,5	12



Extraction sleeves

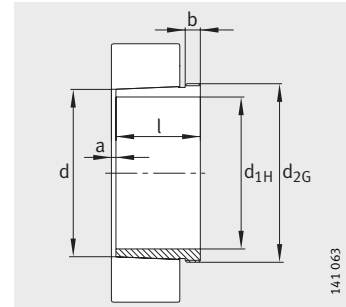

Taper 1:12

Dimension table (continued) · Dimensions in mm										
Designation	Mass m ≈kg	Dimensions						Mounting dimensions		
		d _{1H}	d	l	a ≈	b	d _{2G}	R ₀	e	t
AH24060	15,5	280	300	184	18	24	Tr310X4	–	–	–
AH24060G	16,4	280	300	184	18	24	Tr320X5	–	–	–
AH24060G-H	16,4	280	300	184	18	24	Tr320X5	M6	8	7
AH24060-H	15,5	280	300	184	18	24	Tr310X4	M6	8	7
AH3160	21,2	280	300	192	8	30	Tr330X5	–	–	–
AH3160G	20	280	300	192	8	30	Tr320X5	–	–	–
AH3160G-H	20	280	300	192	8	30	Tr320X5	G1/8	8,5	12
AH3160-H	21,2	280	300	192	8	30	Tr330X5	G1/8	8,5	12
AH24160	20,1	280	300	224	18	24	Tr320X5	–	–	–
AH24160-H	20,1	280	300	224	18	24	Tr320X5	G1/8	8,5	12
AH3260	26	280	300	228	8	34	Tr330X5	–	–	–
AH3260G	24,6	280	300	228	8	34	Tr320X5	–	–	–
AH3260G-H	24,6	280	300	228	8	34	Tr320X5	G1/8	8,5	12
AH3260-H	26	280	300	228	8	34	Tr330X5	G1/8	8,5	12
AH3360	31,8	280	300	270	8	34	Tr330X5	–	–	–
AH3360-H	31,8	280	300	270	8	34	Tr330X5	G1/8	8,5	12
AH3964G-H	11,5	300	320	112	7	21	Tr340X5	M8	7,5	12
AH3964-H	11,1	300	320	112	7	21	Tr335X5	M8	7,5	12
AH3064G-H	15,9	300	320	149	8	27	Tr340X5	G1/8	8,5	12
AH3064-H	16,5	300	320	149	8	27	Tr345X5	G1/8	8,5	12
AH24064G-H	17,5	300	320	184	18	24	Tr340X5	M6	8	7
AH24064-H	16,6	300	320	184	18	24	Tr330X5	M6	8	7
AH3164G-H	23,6	300	320	209	8	31	Tr340X5	G1/8	8,5	12
AH3164-H	24,9	300	320	209	8	31	Tr350X5	G1/8	8,5	12
AH24164-H	23,4	300	320	242	18	24	Tr340X5	G1/8	8,5	12
AH3264G-H	28,9	300	320	246	8	36	Tr340X5	G1/8	8,5	12
AH3264-H	30,4	300	320	246	8	36	Tr350X5	G1/8	8,5	12
AH3364-H	37,9	300	320	294	8	36	Tr350X5	G1/8	8,5	12
AH3968G-H	12,3	320	340	112	7	21	Tr360X5	M8	7,5	12
AH3968-H	11,8	320	340	112	7	21	Tr355X5	M8	7,5	12
AH3068G-H	18,6	320	340	162	9	28	Tr360X5	G1/8	8,5	12
AH3068-H	19,2	320	340	162	9	28	Tr365X5	G1/8	8,5	12
AH24068-H	21,1	320	340	206	19	26	Tr360X5	G1/8	8,5	12
AH3168G-H	27,5	320	340	225	9	33	Tr360X5	G1/8	8,5	12
AH3168-H	28,9	320	340	225	9	33	Tr370X5	G1/8	8,5	12
AH3268G-H	33,6	320	340	264	9	38	Tr360X5	G1/8	8,5	12
AH3268-H	35,3	320	340	264	9	38	Tr370X5	G1/8	8,5	12
AH24168-H	28	320	340	269	19	26	Tr360X5	G1/8	8,5	12

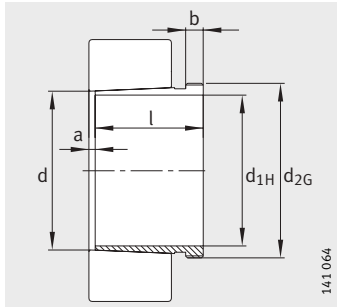

AH240, AH241
Taper 1:30

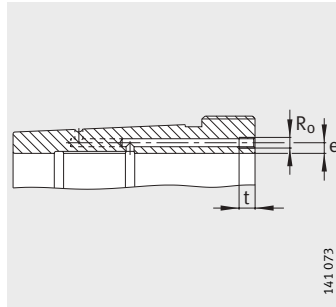

Hydraulic extraction sleeve
(suffix H)
Mounting dimensions

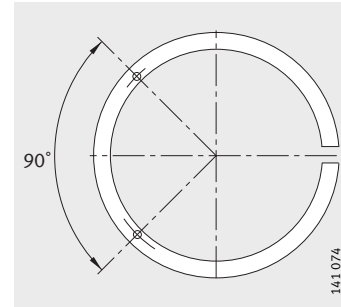

Pump connectors for
hydraulic extraction sleeve

Dimension table (continued) · Dimensions in mm										
Designation	Mass m ≈kg	Dimensions						Mounting dimensions		
		d _{1H}	d	l	a ≈	b	d _{2G}	R ₀	e	t
AH3368-H	43,1	320	340	310	9	38	Tr370X5	G1/8	8,5	12
AH3972G-H	13	340	360	112	7	21	Tr380X5	M8	7,5	12
AH3972-H	12,5	340	360	112	7	21	Tr375X5	M8	7,5	12
AH3072G-H	20,5	340	360	167	9	30	Tr380X5	G1/8	8,5	12
AH3072-H	21,2	340	360	167	9	30	Tr385X5	G1/8	8,5	12
AH24072-H	22,3	340	360	206	20	26	Tr380X5	G1/8	8,5	12
AH3172G-H	29,8	340	360	229	9	35	Tr380X5	G1/8	8,5	12
AH3172-H	33,1	340	360	229	9	35	Tr400X5	G1/8	8,5	12
AH24172-H	29,7	340	360	269	20	26	Tr380X5	G1/8	8,5	12
AH3272G-H	37,3	340	360	274	9	40	Tr380X5	G1/8	8,5	12
AH3272-H	41,1	340	360	274	9	40	Tr400X5	G1/8	8,5	12
AH3372-H	51,5	340	360	330	9	40	Tr400X5	G1/8	8,5	12
AH3976G-H	16,1	360	380	130	8	22	Tr400X5	M8	7,5	12
AH3976-H	15,6	360	380	130	8	22	Tr395X5	M8	7,5	12
AH3076G-H	22,1	360	380	170	10	31	Tr400X5	G1/8	8,5	12
AH3076-H	23,6	360	380	170	10	31	Tr410X5	G1/8	8,5	12
AH24076-H	24	360	380	208	20	28	Tr400X5	G1/8	8,5	12
AH3176G-H	32	360	380	232	10	36	Tr400X5	G1/8	8,5	12
AH3176-H	35,6	360	380	232	10	36	Tr420X5	G1/8	8,5	12
AH24176-H	31,8	360	380	271	20	28	Tr400X5	G1/8	8,5	12
AH3276G-H	41,3	360	380	284	10	42	Tr400X5	G1/8	8,5	12
AH3276-H	45,5	360	380	284	10	42	Tr420X5	G1/8	8,5	12
AH3376-H	57,1	360	380	342	10	42	Tr420X5	G1/8	8,5	12
AH3980G-H	17	380	400	130	8	22	Tr420X5	M8	7,5	12
AH3980-H	16,4	380	400	130	8	22	Tr415X5	M8	7,5	12
AH3080G-H	25,4	380	400	183	10	33	Tr420X5	G1/8	8,5	12
AH3080-H	27,1	380	400	183	10	33	Tr430X5	G1/8	8,5	12
AH24080-H	27,8	380	400	228	20	28	Tr420X5	G1/8	8,5	12
AH3180G-H	35,1	380	400	240	10	38	Tr420X5	G1/8	8,5	12
AH3180-H	39,1	380	400	240	10	38	Tr440X5	G1/8	8,5	12
AH24180-H	34,4	380	400	278	20	28	Tr420X5	G1/8	8,5	12
AH3280G-H	47,1	380	400	302	10	44	Tr420X5	G1/8	8,5	12
AH3280-H	51,7	380	400	302	10	44	Tr440X5	G1/8	8,5	12
AH3380-H	62,5	380	400	352	10	44	Tr440X5	G1/8	8,5	12
AH3984G-H	17,8	400	420	130	8	22	Tr440X5	M8	7,5	12
AH3984-H	17,3	400	420	130	8	22	Tr435X5	M8	7,5	12
AH3084G-H	27,2	400	420	186	10	34	Tr440X5	G1/8	8,5	12
AH3084-H	29,1	400	420	186	10	34	Tr450X5	G1/8	8,5	12



Extraction sleeves

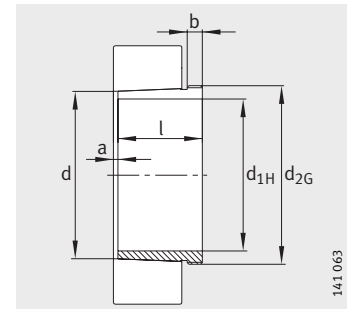

Taper 1:12

Dimension table (continued) · Dimensions in mm										
Designation	Mass m ≈kg	Dimensions						Mounting dimensions		
		d _{1H}	d	l	a ≈	b	d _{2G}	R ₀	e	t
AH24084-H	29,6	400	420	230	22	30	Tr440X5	G1/8	8,5	12
AH3184G-H	42	400	420	266	10	40	Tr440X5	G1/8	8,5	12
AH3184-H	46,4	400	420	266	10	40	Tr460X5	G1/8	8,5	12
AH24184-H	41	400	420	310	22	30	Tr440X5	G1/8	8,5	12
AH3284G-H	53,6	400	420	321	10	46	Tr440X5	G1/8	8,5	12
AH3284-H	58,6	400	420	321	10	46	Tr460X5	G1/8	8,5	12
AH3384-H	67,9	400	420	361	10	46	Tr460X5	G1/8	8,5	12
AH3988-H	21,2	420	440	145	8	25	Tr460X5	G1/8	8,5	12
AHX3088G-H	30	420	440	194	11	35	Tr460X5	G1/8	8,5	12
AHX3088-H	31,9	420	440	194	11	35	Tr470X5	G1/8	8,5	12
AH24088-H	32,8	420	440	242	22	30	Tr460X5	G1/8	8,5	12
AHX3188G-H	44,9	420	440	270	11	42	Tr460X5	G1/8	8,5	12
AHX3188-H	49,7	420	440	270	11	42	Tr480X5	G1/8	8,5	12
AH24188-H	42,9	420	440	310	22	30	Tr460X5	G1/8	8,5	12
AHX3288G-H	58,2	420	440	330	11	48	Tr460X5	G1/8	8,5	12
AHX3288-H	63,7	420	440	330	11	48	Tr480X5	G1/8	8,5	12
AH3388-H	79,6	420	440	393	11	48	Tr480X5	G1/8	8,5	12
AH3992-H	22,2	440	460	145	8	25	Tr480X5	G1/8	8,5	12
AHX3092G-H	32,9	440	460	202	11	37	Tr480X5	G1/8	8,5	12
AHX3092G-H	35,1	440	460	202	11	37	Tr490X5	G1/8	8,5	12
AH24092-H	35,6	440	460	250	23	32	Tr480X5	G1/8	8,5	12
AHX3192G-H	50,3	440	460	285	11	43	Tr480X5	G1/8	8,5	12
AHX3192-H	58	440	460	285	11	43	Tr510X6	G1/8	8,5	12
AH24192-H	48,7	440	460	332	23	32	Tr480X5	G1/8	8,5	12
AHX3292G-H	65,6	440	460	349	11	50	Tr480X5	G1/8	8,5	12
AHX3292-H	74,6	440	460	349	11	50	Tr510X6	G1/8	8,5	12
AH3392-H	92,6	440	460	415	11	50	Tr510X6	G1/8	8,5	12
AH3996-H	25,7	460	480	158	9	28	Tr500X5	G1/8	8,5	12
AHX3096G-H	35	460	480	205	12	38	Tr500X5	G1/8	8,5	12
AHX3096-H	39,7	460	480	205	12	38	Tr520X6	G1/8	8,5	12
AH24096-H	37,2	460	480	250	23	32	Tr500X5	G1/8	8,5	12
AHX3196G-H	54,8	460	480	295	12	45	Tr500X5	G1/8	8,5	12
AHX3196-H	63,3	460	480	295	12	45	Tr530X6	G1/8	8,5	12
AH24196G-H	52,2	460	480	340	23	32	Tr500X5	G1/8	8,5	12
AH24196-H	52,9	460	480	343	25	35	Tr500X5	G1/8	8,5	12
AHX3296G-H	72,4	460	480	364	12	52	Tr500X5	G1/8	8,5	12
AHX3296-H	82,2	460	480	364	12	52	Tr530X6	G1/8	8,5	12
AH3396-H	100	460	480	427	12	52	Tr530X6	G1/8	8,5	12

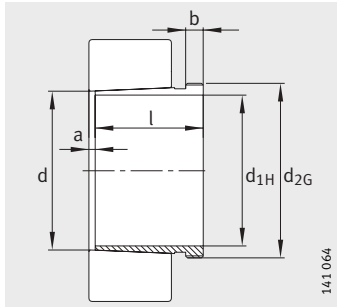

AH240, AH241
Taper 1:30

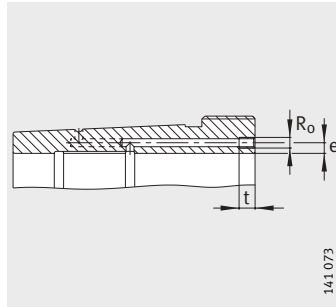

Hydraulic extraction sleeve
Mounting dimensions

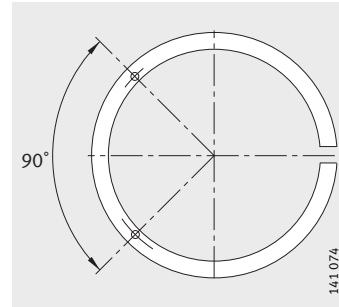

Pump connectors for
hydraulic extraction sleeve

Dimension table (continued) · Dimensions in mm										
Designation	Mass m ≈kg	Dimensions						Mounting dimensions		
		d _{1H}	d	l	a ≈	b	d _{2G}	R ₀	e	t
AH39/500G-H	29,8	480	500	162	10	32	Tr530X6	G1/8	8,5	12
AH39/500-H	27,7	480	500	162	10	32	Tr520X6	G1/8	8,5	12
AHX30/500G-H	39,9	480	500	209	12	40	Tr530X6	G1/8	8,5	12
AHX30/500-H	42,5	480	500	209	12	40	Tr540X6	G1/8	8,5	12
AH240/500G-H	41,7	480	500	253	23	35	Tr530X6	G1/8	8,5	12
AH240/500-H	39,5	480	500	253	23	35	Tr520X6	G1/8	8,5	12
AHX31/500G-H	64,7	480	500	313	12	47	Tr530X6	G1/8	8,5	12
AHX31/500-H	70,9	480	500	313	12	47	Tr550X6	G1/8	8,5	12
AH241/500G-H	60,5	480	500	360	23	35	Tr530X6	G1/8	8,5	12
AH241/500-H	58,8	480	500	362	25	37	Tr520X6	G1/8	8,5	12
AHX32/500G-H	87,3	480	500	393	12	54	Tr530X6	G1/8	8,5	12
AHX32/500-H	94,4	480	500	393	12	54	Tr550X6	G1/8	8,5	12
AH33/500-H	110	480	500	442	12	54	Tr550X6	G1/8	8,5	12
AH39/530G-H	45,6	500	530	175	10	37	Tr560X6	G1/4	10	15
AH39/530-H	43,1	500	530	175	10	37	Tr550X6	G1/4	10	15
AH30/530A-H	61,7	500	530	230	12	45	Tr560X6	G1/4	10	15
AH240/530G-H	67,5	500	530	285	24	35	Tr560X6	G1/4	8,5	15
AH240/530-H	66,8	500	530	290	25	40	Tr550X6	G1/4	8,5	15
AH31/530A-H	92,3	500	530	325	12	53	Tr560X6	G1/4	10	15
AH241/530G-H	89	500	530	370	24	35	Tr560X6	G1/4	10	15
AH241/530-H	88,2	500	530	375	25	40	Tr550X6	G1/4	10	15
AH32/530AG-H	124	500	530	412	12	57	Tr560X6	G1/4	10	15
AH32/530-A-H	132	500	530	412	12	57	Tr580X6	G1/4	10	15
AH33/530-H	155	500	530	469	12	57	Tr580X6	G1/4	10	15
AH39/560G-H	52,3	530	560	180	10	37	Tr600X6	G1/4	12	15
AH39/560-H	47	530	560	180	10	37	Tr580X6	G1/4	12	15
AH30/560AG-H	71,6	530	560	240	12	45	Tr600X6	G1/4	12	15
AH30/560A-H	68,4	530	560	240	12	45	Tr590X6	G1/4	12	15
AH240/560G-H	77,5	530	560	296	24	38	Tr600X6	G1/4	8,5	15
AH240/560-H	72,7	530	560	298	25	40	Tr580X6	G1/4	8,5	15
AH31/560AG-H	105	530	560	335	12	55	Tr600X6	G1/4	12	15
AH31/560A-H	101	530	560	335	12	55	Tr590X6	G1/4	12	15
AH241/560G-H	104	530	560	393	24	38	Tr600X6	G1/4	12	15
AH241/560-H	101	530	560	400	28	45	Tr580X6	G1/4	12	15
AH32/560AG-H	139	530	560	422	12	57	Tr600X6	G1/4	12	15
AH32/560A-H	144	530	560	422	12	57	Tr610X6	G1/4	12	15
AH33/560-H	166	530	560	475	12	57	Tr610X6	G1/4	12	15
AH39/600G-H	57	570	600	192	10	38	Tr630X6	G1/4	12	15



Extraction sleeves

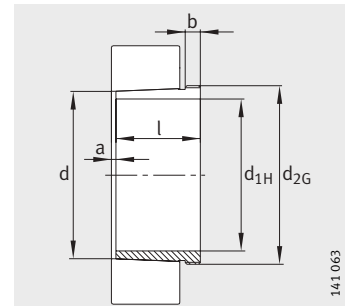

Taper 1:12

Dimension table (continued) · Dimensions in mm										
Designation	Mass m ≈kg	Dimensions						Mounting dimensions		
		d _{1H}	d	l	a ≈	b	d _{2G}	R ₀	e	t
AH39/600-H	55,6	570	600	192	10	38	Tr625X6	G1/4	12	15
AH30/600A-H	75	570	600	245	14	45	Tr630X6	G1/4	12	15
AH240/600G-H	84,1	570	600	310	26	38	Tr630X6	G1/4	8,5	15
AH240/600-H	85,4	570	600	317	30	45	Tr625X6	G1/4	8,5	15
AH31/600A-H	116	570	600	355	14	55	Tr630X6	G1/4	12	15
AH241/600G-H	114	570	600	413	26	38	Tr630X6	G1/4	12	15
AH241/600-H	118	570	600	425	30	50	Tr625X6	G1/4	12	15
AH32/600AG-H	155	570	600	445	14	57	Tr630X6	G1/4	12	15
AH32/600A-H	164	570	600	445	14	57	Tr650X6	G1/4	12	15
AH33/600-H	200	570	600	519	14	57	Tr650X6	G1/4	12	15
AH39/630G-H	69,4	600	630	210	12	40	Tr670X6	G1/4	12	15
AH39/630-H	64,5	600	630	210	12	40	Tr655X6	G1/4	12	15
AH30/630A-H	87,3	600	630	258	14	46	Tr670X6	G1/4	12	15
AH240/630G-H	97,9	600	630	330	26	40	Tr670X6	G1/4	8,5	15
AH240/630-H	95,1	600	630	335	30	45	Tr655X6	G1/4	8,5	15
AH31/630A-H	136	600	630	375	14	60	Tr670X6	G1/4	12	15
AH241/630G-H	133	600	630	440	26	40	Tr670X6	G1/4	12	15
AH241/630-H	132	600	630	450	30	50	Tr655X6	G1/4	12	15
AH32/630AG-H	183	600	630	475	14	63	Tr670X6	G1/4	12	15
AH32/630A-H	188	600	630	475	14	63	Tr680X6	G1/4	12	15
AH33/630-H	227	600	630	550	14	62	Tr680X6	G1/4	12	15
AH39/670G-H	92,9	630	670	216	12	41	Tr710X7	G1/4	12	15
AH39/670-H	87,7	630	670	216	12	41	Tr695X6	G1/4	12	15
AH30/670A-H	124	630	670	280	14	50	Tr710X7	G1/4	12	15
AH240/670G-H	137	630	670	348	26	40	Tr710X7	G1/4	8,5	15
AH240/670-H	137	630	670	358	30	50	Tr695X6	G1/4	8,5	15
AH31/670A-H	185	630	670	395	14	60	Tr710X7	G1/4	12	15
AH241/670G-H	180	630	670	452	26	40	Tr710X7	G1/4	12	15
AH241/670-H	183	630	670	467	30	55	Tr695X6	G1/4	12	15
AH32/670AG-H	247	630	670	500	14	63	Tr710X7	G1/4	12	15
AH32/670A-H	252	630	670	500	14	63	Tr720X7	G1/4	12	15
AH33/670-H	303	630	670	577	14	62	Tr720X7	G1/4	12	15
AH39/710G-H	105	670	710	228	12	43	Tr750X7	G1/4	15	15
AH39/710-H	101	670	710	228	12	43	Tr740X7	G1/4	15	15
AH30/710A-H	135	670	710	286	16	50	Tr750X7	G1/4	15	15
AH240/710G-H	152	670	710	360	26	45	Tr750X7	G1/4	8,5	15
AH240/710-H	151	670	710	365	33	50	Tr740X7	G1/4	8,5	15
AH31/710A-H	202	670	710	405	16	60	Tr750X7	G1/4	15	15

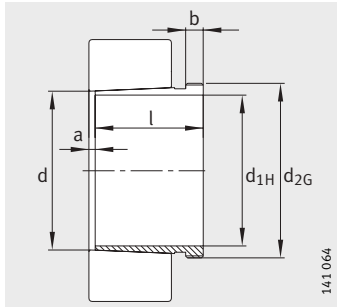

AH240, AH241
Taper 1:30

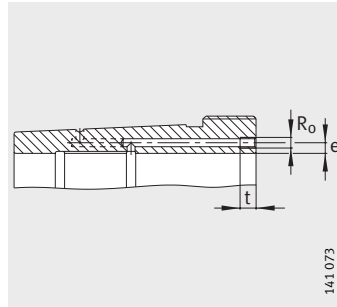

Hydraulic extraction sleeve
Mounting dimensions

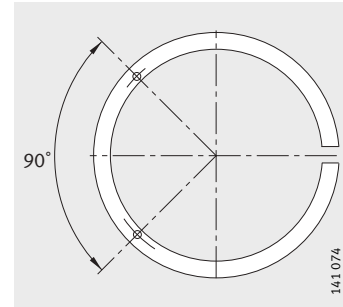

Pump connectors for
hydraulic extraction sleeve

Dimension table (continued) · Dimensions in mm										
Designation	Mass m ≈kg	Dimensions						Mounting dimensions		
		d _{1H}	d	l	a ≈	b	d _{2G}	R ₀	e	t
AH241/710G-H	207	670	710	483	26	45	Tr750X7	G1/4	15	15
AH241/710-H	209	670	710	493	33	55	Tr740X7	G1/4	15	15
AH32/710AG-H	272	670	710	515	16	65	Tr750X7	G1/4	15	15
AH32/710A-H	278	670	710	515	16	65	Tr760X7	G1/4	15	15
AH33/710-H	334	670	710	595	16	65	Tr760X7	G1/4	15	15
AH39/750G-H	118	710	750	234	12	44	Tr800X7	G1/4	15	15
AH39/750-H	110	710	750	234	12	44	Tr780X7	G1/4	15	15
AH30/750A-H	155	710	750	300	16	50	Tr800X7	G1/4	15	15
AH240/750G-H	174	710	750	380	28	45	Tr800X7	G1/4	8,5	15
AH240/750-H	169	710	750	385	35	50	Tr780X7	G1/4	8,5	15
AH31/750A-H	232	710	750	425	16	60	Tr800X7	G1/4	15	15
AH241/750G-H	241	710	750	520	28	45	Tr800X7	G1/4	15	15
AH241/750-H	239	710	750	530	35	55	Tr780X7	G1/4	15	15
AH32/750A-H	312	710	750	540	16	65	Tr800X7	G1/4	15	15
AH33/750-H	377	710	750	625	16	65	Tr800X7	G1/4	15	15
AH39/800G-H	155	750	800	245	12	45	Tr850X7	G1/4	15	15
AH39/800-H	146	750	800	245	12	45	Tr830X7	G1/4	15	15
AH30/800A-H	198	750	800	308	18	50	Tr850X7	G1/4	15	15
AH240/800G-H	232	750	800	395	28	50	Tr850X7	G1/4	15	15
AH240/800-H	221	750	800	395	40	50	Tr830X7	G1/4	15	15
AH31/800A-H	297	750	800	438	18	63	Tr850X7	G1/4	15	15
AH241/800G-H	311	750	800	525	28	50	Tr850X7	G1/4	15	15
AH241/800-H	304	750	800	530	40	55	Tr830X7	G1/4	15	15
AH32/800AG-H	391	750	800	550	18	62	Tr850X7	G1/4	15	15
AH32/800A-H	396	750	800	555	18	67	Tr850X7	G1/4	15	15
AH33/800-H	500	750	800	667	18	67	Tr850X7	G1/4	15	15
AH39/850G-H	176	800	850	258	12	50	Tr900X7	G1/4	15	15
AH39/850-H	165	800	850	258	12	50	Tr880X7	G1/4	15	15
AH30/850A-H	224	800	850	325	18	53	Tr900X7	G1/4	15	15
AH240/850G-H	259	800	850	415	30	50	Tr900X7	G1/4	15	15
AH240/850-H	250	800	850	418	40	53	Tr880X7	G1/4	15	15
AH31/850A-H	336	800	850	462	18	63	Tr900X7	G1/4	15	15
AH241/850G-H	358	800	850	560	40	60	Tr900X7	G1/4	15	15
AH241/850-H	345	800	850	560	40	60	Tr880X7	G1/4	15	15
AH32/850A-H	450	800	850	585	18	70	Tr900X7	G1/4	15	15
AH33/850-H	567	800	850	700	18	70	Tr900X7	G1/4	15	15



Extraction sleeves

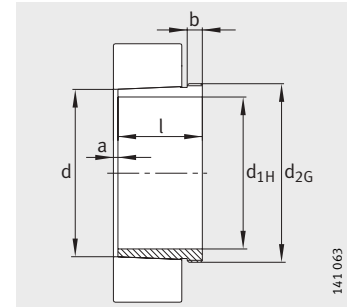

Taper 1:12

Dimension table (continued) · Dimensions in mm										
Designation	Mass m ≈kg	Dimensions						Mounting dimensions		
		d _{1H}	d	l	a ≈	b	d _{2G}	R ₀	e	t
AH39/900G-H	192	850	900	265	12	51	Tr950X8	G1/4	15	15
AH39/900-H	180	850	900	265	12	51	Tr930X8	G1/4	15	15
AH30/900A-H	246	850	900	335	20	55	Tr950X8	G1/4	15	15
AH240/900G-H	287	850	900	430	45	55	Tr950X8	G1/4	15	15
AH240/900-H	274	850	900	430	45	55	Tr930X8	G1/4	15	15
AH31/900A-H	368	850	900	475	20	63	Tr950X8	G1/4	15	15
AH241/900G-H	390	850	900	575	45	60	Tr950X8	G1/4	15	15
AH241/900-H	376	850	900	575	45	60	Tr930X8	G1/4	15	15
AH32/900A-H	476	850	900	585	20	70	Tr950X8	G1/4	15	15
AH33/900-H	623	850	900	720	20	70	Tr950X8	G1/4	15	15
AH39/950G-H	216	900	950	282	15	51	Tr1000X8	G1/4	15	15
AH39/950-H	203	900	950	282	15	51	Tr980X8	G1/4	15	15
AH30/950A-H	277	900	950	355	20	55	Tr1000X8	G1/4	15	15
AH240/950G-H	329	900	950	467	45	55	Tr1000X8	G1/4	15	15
AH240/950-H	316	900	950	467	45	55	Tr980X8	G1/4	15	15
AH31/950A-H	414	900	950	500	20	63	Tr1000X8	G1/4	15	15
AH32/950A-H	519	900	950	600	20	70	Tr1000X8	G1/4	15	15
AH241/950G-H	435	900	950	605	45	60	Tr1000X8	G1/4	15	15
AH241/950-H	421	900	950	605	45	60	Tr980X8	G1/4	15	15
AH33/950-H	683	900	950	740	20	70	Tr1000X8	G1/4	15	15
AH39/1000G-H	246	950	1000	296	15	52	Tr1060X8	G1/4	15	15
AH39/1000-H	229	950	1000	296	15	52	Tr1035X8	G1/4	15	15
AH30/1,000A-H	309	950	1000	365	22	57	Tr1060X8	G1/4	15	15
AH240/1000G-H	357	950	1000	469	50	57	Tr1060X8	G1/4	15	15
AH240/1000-H	339	950	1000	469	50	57	Tr1035X8	G1/4	15	15
AH31/1,000A-H	471	950	1000	525	22	63	Tr1060X8	G1/4	15	15
AH32/1,000A-H	591	950	1000	630	22	70	Tr1060X8	G1/4	15	15
AH241/1000-H	502	950	1000	645	50	65	Tr1060X8	G1/4	15	15
AH33/1000-H	781	950	1000	780	22	70	Tr1060X8	G1/4	15	15
AH39/1060G-H	312	1000	1060	310	15	52	Tr1120X8	G1/4	15	15
AH39/1060-H	294	1000	1060	310	15	52	Tr1095X8	G1/4	15	15
AH30/1,060A-H	396	1000	1060	385	22	60	Tr1120X8	G1/4	15	15
AH240/1060G-H	465	1000	1060	498	50	60	Tr1120X8	G1/4	15	15
AH240/1060-H	445	1000	1060	498	50	60	Tr1095X8	G1/4	15	15
AH31/1,060A-H	583	1000	1060	540	22	65	Tr1120X8	G1/4	15	15
AH241/1060-H	632	1000	1060	665	50	65	Tr1120X8	G1/4	15	15
AH30/1,120A-H	451	1060	1120	410	22	65	Tr1180X8	G1/4	15	15
AH240/1120G-H	524	1060	1120	527	50	65	Tr1180X8	G1/4	15	15

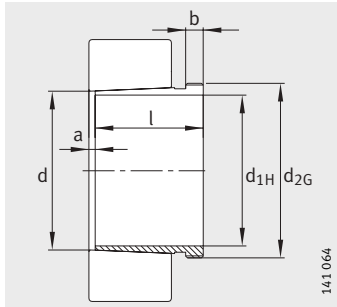

AH240, AH241
Taper 1:30

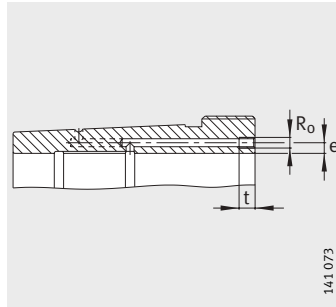

Hydraulic extraction sleeve
Mounting dimensions

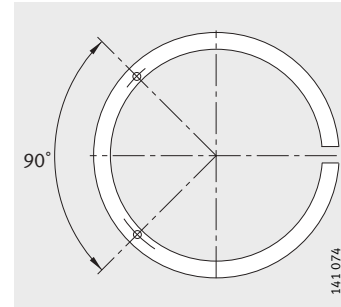

Pump connectors for
hydraulic extraction sleeve

Dimension table (continued) · Dimensions in mm										
Designation	Mass m ≈kg	Dimensions						Mounting dimensions		
		d _{1H}	d	l	a ≈	b	d _{2G}	R ₀	e	t
AH240/1120-H	501	1 060	1 120	527	50	65	Tr1155X8	G1/4	15	15
AH241/1120-H	717	1 060	1 120	705	50	75	Tr1180X8	G1/4	15	15
AH39/1120G-H	289	1 070	1 120	310	15	52	Tr1180X8	G1/4	15	15
AH39/1120-H	271	1 070	1 120	310	15	52	Tr1155X8	G1/4	15	15
AH30/1,180A-H	498	1 120	1 180	420	22	65	Tr1250X8	G1/4	15	15
AH240/1180G-H	577	1 120	1 180	540	50	65	Tr1250X8	G1/4	15	15
AH240/1180-H	543	1 120	1 180	540	50	65	Tr1215X8	G1/4	15	15
AH241/1180-H	824	1 120	1 180	750	50	80	Tr1250X8	G1/4	15	15
AH39/1180G-H	336	1 130	1 180	330	15	55	Tr1250X8	G1/4	15	15
AH39/1180-H	307	1 130	1 180	330	15	55	Tr1215X8	G1/4	15	15
AH30/1,250A-H	629	1 180	1 250	445	22	70	Tr1320X8	G1/4	15	15
AH240/1250G-H	733	1 180	1 250	570	50	70	Tr1320X8	G1/4	15	15
AH240/1250-H	694	1 180	1 250	570	50	70	Tr1285X8	G1/4	15	15
AH241/1250-H	1 048	1 180	1 250	795	50	85	Tr1320X8	G1/4	15	15
AH39/1250G-H	367	1 200	1 250	340	18	55	Tr1320X8	G1/4	15	15
AH39/1250-H	336	1 200	1 250	340	18	55	Tr1285X8	G1/4	15	15
AH30/1,320A-H	718	1 250	1 320	470	22	70	Tr1400X8	G1/4	15	15
AH240/1320G-H	828	1 250	1 320	600	50	70	Tr1400X8	G1/4	15	15
AH240/1320-H	775	1 250	1 320	600	50	70	Tr1355X8	G1/4	15	15
AH241/1320-H	1 194	1 250	1 320	840	50	90	Tr1400X8	G1/4	15	15
AH39/1320G-H	421	1 270	1 320	360	18	55	Tr1400X8	G1/4	15	15
AH39/1320-H	379	1 270	1 320	360	18	55	Tr1355X8	G1/4	15	15
AH30/1,400A-H	902	1 320	1 400	487	22	75	Tr1500X8	G1/4	15	15
AH240/1400G-H	1 026	1 320	1 400	615	50	70	Tr1500X8	G1/4	15	15
AH240/1400-H	944	1 320	1 400	615	50	70	Tr1435X8	G1/4	15	15
AH241/1400-H	1 496	1 320	1 400	870	50	95	Tr1500X8	G1/4	15	15
AH39/1400G-H	499	1 350	1 400	380	20	60	Tr1500X8	G1/4	15	15
AH39/1400-H	429	1 350	1 400	380	20	60	Tr1435X8	G1/4	15	15
AH30/1,500A-H	1 257	1 400	1 500	537	22	75	Tr1600X8	G1/4	15	15
AH241/1500-H	1 961	1 400	1 500	895	50	95	Tr1600X8	G1/4	15	15
AH39/1500G-H	563	1 450	1 500	400	20	60	Tr1600X8	G1/4	15	15
AH39/1500-H	494	1 450	1 500	400	20	60	Tr1540X8	G1/4	15	15



Locknuts

Dimension table · Dimensions in mm								
Designation		Mass m ≈kg	Dimensions			Mounting dimensions		
Nut	Suitable retainer		d _{2G}	D _m	b ₁	D _a	m	n
KM0	MB0	0,005	M10X0,75	18	4	13,5	3	2
KM1	MB1	0,007	M12X1	22	4	17	3	2
KM2	MB2	0,01	M15X1	25	5	21	4	2
KM3	MB3	0,02	M17X1	28	5	24	4	2
KM4	MB4	0,019	M20X1	32	6	26	4	2
KM5	MB5	0,025	M25X1,5	38	7	32	5	2
KM6	MB6	0,043	M30X1,5	45	7	38	5	2
KM7	MB7	0,07	M35X1,5	52	8	44	5	2
KM8	MB8	0,085	M40X1,5	58	9	50	6	2,5
KM9	MB9	0,119	M45X1,5	65	10	56	6	2,5
KM10	MB10	0,148	M50X1,5	70	11	61	6	2,5
KM11	MB11	0,158	M55X2	75	11	67	7	3
KM12	MB12	0,18	M60X2	80	11	73	7	3
KM13	MB13	0,22	M65X2	85	12	79	7	3
KM14	MB14	0,26	M70X2	92	12	85	8	3,5
KM15	MB15	0,3	M75X2	98	13	90	8	3,5
KM16	MB16	0,4	M80X2	105	15	95	8	3,5
KM17	MB17	0,46	M85X2	110	16	102	8	3,5
KM18	MB18	0,6	M90X2	120	16	108	10	4
KM19	MB19	0,658	M95X2	125	17	113	10	4
KM20	MB20	0,73	M100X2	130	18	120	10	4
KM21	MB21	0,87	M105X2	140	18	126	12	5
KM22	MB22	0,965	M110X2	145	19	133	12	5
KM23	MB23	1,01	M115X2	150	19	137	12	5
KML24	MBL24	0,79	M120X2	145	20	135	12	5
KM24	MB24	1,08	M120X2	155	20	138	12	5
KM25	MB25	1,22	M125X2	160	21	148	12	5
KML26	MBL26	0,9	M130X2	155	21	145	12	5
KM26	MB26	1,24	M130X2	165	21	149	12	5
KM27	MB27	1,55	M135X2	175	22	160	14	6
KML28	MBL28	1,01	M140X2	165	22	155	12	5
KM28	MB28	1,56	M140X2	180	22	160	14	6
KM29	MB29	2,05	M145X2	190	24	171	14	6

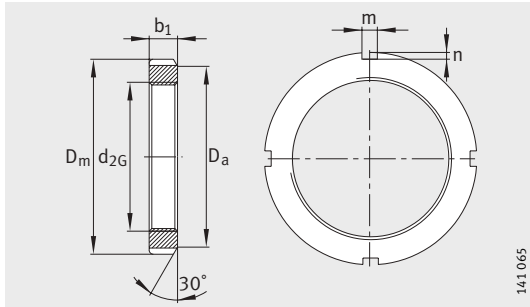

KM, KML, HM..T

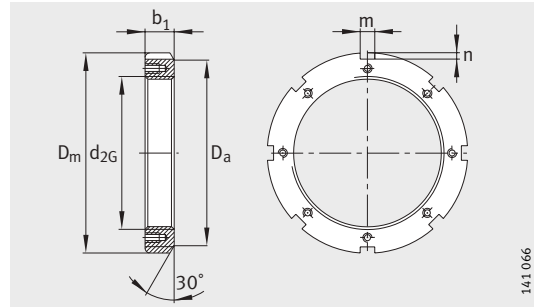

HM30, HM31

Dimension table (continued) · Dimensions in mm								
Designation		Mass m ≈ kg	Dimensions			Mounting dimensions		
Nut	Suitable retainer		d _{2G}	D _m	b ₁	D _a	m	n
KML30	MBL30	1,44	M150X2	180	24	170	14	5
KM30	MB30	2,06	M150X2	195	24	171	14	6
KM31	MB31	2,27	M155X3	200	25	182	16	7
KML32	MBL32	1,62	M160X3	190	25	180	14	5
KM32	MB32	2,52	M160X3	210	25	182	16	7
KM33	MB33	2,7	M165X3	210	26	193	16	7
KML34	MBL34	1,72	M170X3	200	26	190	16	5
KM34	MB34	2,8	M170X3	220	26	193	16	7
KML36	MBL36	1,96	M180X3	210	27	200	16	5
KM36	MB36	3,04	M180X3	230	27	203	18	8
KML38	MBL38	2,13	M190X3	220	28	210	16	5
KM38	MB38	3,34	M190X3	240	28	214	18	8
KML40	MBL40	2,9	M200X3	240	29	220	18	8
KM40	MB40	3,69	M200X3	250	29	226	18	8
HM3044	MS3044	3,21	Tr220X4	260	30	242	20	9
HM44T	MB44	5,3	Tr220X4	280	32	250	20	10
HM3144	MS3144	4,93	Tr220X4	280	32	250	20	10
HM3048	MS3048	5,12	Tr240X4	290	34	270	20	10
HM48T	MB48	6,15	Tr240X4	300	34	270	20	10
HM3148	MS3144	5,75	Tr240X4	300	34	270	20	10
HM3052	MS3048	5,54	Tr260X4	310	34	290	20	10
HM52T	MB52	8,05	Tr260X4	330	35	300	24	12
HM3152	MS3152	7,43	Tr260X4	330	36	300	24	12
HM3056	MS3056	6,61	Tr280X4	330	38	310	24	10
HM56T	MB56	8,9	Tr280X4	350	36	320	24	12
HM3156	MS3152	8,26	Tr280X4	350	38	320	24	12
HM3060	MS3060	9,48	Tr300X4	360	42	336	24	12
HM3160	MS3160	11,4	Tr300X4	380	40	340	24	12
HM3064	MS3064	10,1	Tr320X5	380	42	356	24	12
HM3164	MS3164	12,8	Tr320X5	400	42	360	24	12
HM3068	MS3064	11,5	Tr340X5	400	45	376	24	12
HM3168	MS3168	23	Tr340X5	440	55	400	28	15
HM3072	MS3072	11,9	Tr360X5	420	45	394	28	13
HM3172	MS3168	25,7	Tr360X5	460	58	420	28	15
HM3076	MS3076	15,9	Tr380X5	450	48	422	28	14
HM3176	MS3176	30	Tr380X5	490	60	440	32	18



Locknuts

Dimension table (continued) - Dimensions in mm								
Designation		Mass m ≈kg	Dimensions			Mounting dimensions		
Nut	Suitable retainer		d _{2G}	D _m	b ₁	D _a	m	n
HM3080	MS3076	18,2	Tr400X5	470	52	442	28	14
HM3180	MS3180	35,7	Tr400X5	520	62	460	32	18
HM3084	MS3084	18,9	Tr420X5	490	52	462	32	14
HM3184	MS3180	43,4	Tr420X5	540	70	490	32	18
HM3088	MS3088	26,5	Tr440X5	520	60	490	32	15
HM3188	MS3188	44,3	Tr440X5	560	70	510	36	20
HM3092	MS3088	27,7	Tr460X5	540	60	510	32	15
HM3192	MS3188	53,8	Tr460X5	580	75	540	36	20
HM3096	MS3096	28,7	Tr480X5	560	60	530	36	15
HM3196	MS3196	62,2	Tr480X5	620	75	560	36	20
HM30/500	MS3096	34	Tr500X5	580	68	550	36	15
HM31/500	MS31/500	62,1	Tr500X5	630	80	580	40	23
HM30/530	MS30/530	44,7	Tr530X6	630	68	590	40	20
HM31/530	MS31/530	71,2	Tr530X6	670	80	610	40	23
HM30/560	MS30/560	46,2	Tr560X6	650	75	610	40	20
HM31/560	MS31/560	85,6	Tr560X6	710	85	650	45	25
HM30/600	MS30/530	55,9	Tr600X6	700	75	660	40	20
HM31/600	MS31/560	91,7	Tr600X6	750	85	690	45	25
HM30/630	MS30/630	58,3	Tr630X6	730	75	690	45	20
HM31/630	MS31/630	122	Tr630X6	800	95	730	50	28
HM30/670	MS30/670	73,8	Tr670X6	780	80	740	45	20
HM31/670	MS31/670	156	Tr670X6	850	106	775	50	28
HM30/710	MS30/710	94,8	Tr710X7	830	90	780	50	25
HM31/710	MS31/710	173	Tr710X7	900	106	825	55	30
HM30/750	MS30/750	99,5	Tr750X7	870	90	820	55	25
HM31/750	MS31/750	202	Tr750X7	950	112	875	60	34
HM30/800	MS30/750	106	Tr800X7	920	90	870	55	25
HM31/800	MS31/750	215	Tr800X7	1000	112	925	60	34
HM30/850	MS30/850	113	Tr850X7	980	90	925	60	25
HM31/850	MS31/850	246	Tr850X7	1060	118	975	70	38
HM30/900	MS30/850	135	Tr900X7	1030	100	975	60	25
HM31/900	MS31/900	293	Tr900X7	1120	125	1030	70	38
HM30/950	MS30/950	143	Tr950X8	1080	100	1025	60	25
HM31/950	MS31/950	310	Tr950X8	1170	125	1080	70	38

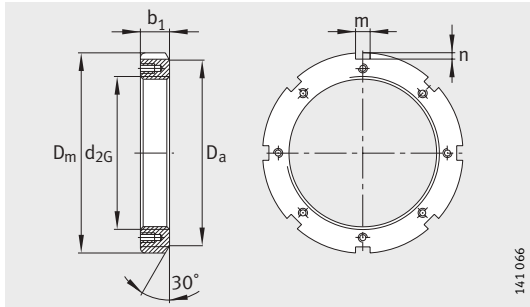

HM30, HM31

Dimension table (continued) · Dimensions in mm								
Designation		Mass m ≈ kg	Dimensions			Mounting dimensions		
Nut	Suitable retainer		d _{2G}	D _m	b ₁	D _a	m	n
HM30/1000	MS30/1000	165	Tr1000X8	1 140	100	1 085	60	25
HM31/1000	MS31/1000	361	Tr1000X8	1 240	125	1 140	70	38
HM30/1060	MS30/1000	175	Tr1060X8	1 200	100	1 145	60	25
HM31/1060	MS31/1000	386	Tr1060X8	1 300	125	1 210	70	38
HM30/1120	MS30/1000	185	Tr1120X8	1 260	100	1 205	60	25
HM31/1120	MS31/1000	427	Tr1120X8	1 360	125	1 270	70	38
HM30/1180	MS30/1000	196	Tr1180X8	1 320	100	1 265	60	25
HM31/1180	MS31/1000	459	Tr1180X8	1 420	125	1 330	70	38
HM30/1250	MS30/1000	233	Tr1250X8	1 390	110	1 335	60	25
HM31/1250	MS31/1000	485	Tr1250X8	1 490	125	1 400	70	38
HM30/1320	MS30/1000	245	Tr1320X8	1 460	110	1 405	60	25
HM31/1320	MS31/1000	511	Tr1320X8	1 560	125	1 470	70	38
HM30/1400	MS30/1000	259	Tr1400X8	1 540	110	1 485	60	25
HM31/1400	MS31/1000	562	Tr1400X8	1 640	130	1 550	70	38
HM30/1500	MS30/1500	297	Tr1500X8	1 650	110	1 595	60	25
HM31/1500	MS31/1000	601	Tr1500X8	1 740	130	1 650	70	38



Retaining plates

Dimension table · Dimensions in mm								
Designation	Mass m 100 pieces ≈kg	Dimensions			Mounting dimensions			
		d	D _s ≈	s	D _a	E ¹⁾	F	K
MB0	0,13	10	21	1	13,5	3	8,5	3
MB1	0,192	12	25	1	17	3	10,5	3
MB2	0,253	15	28	1	21	4	13,5	4
MB3	0,313	17	32	1	24	4	15,5	4
MB4	0,35	20	36	1	26	4	18,5	4
MB5	0,64	25	42	1,25	32	5	23	5
MB6	0,78	30	49	1,25	38	5	27,5	5
MB7	1,04	35	57	1,04	44	6	32,5	5
MB8	1,23	40	62	1,25	50	6	37,5	6
MB9	1,52	45	69	1,25	56	6	42,5	6
MB10	1,6	50	74	1,25	61	6	47,5	6
MB11	1,96	55	81	1	67	8	52,5	7
MB12	2,53	60	86	1	73	8	57,5	7
MB13	2,9	65	92	1	79	8	62,5	7
MB14	3,34	70	98	1	85	8	66,5	8
MB15	3,6	75	104	1	90	8	71,5	8
MB16	4,64	80	112	1,8	95	10	76,5	8
MB17	5,24	85	119	1,8	102	10	81,5	8
MB18	6,23	90	126	1,8	108	10	86,5	10
MB19	6,7	95	133	1,8	113	10	91,5	10
MB20	7,65	100	142	1,8	120	12	96,5	10
MB21	8,26	105	145	1,75	126	12	100,5	12
MB22	9,4	110	154	1,75	133	12	105,5	12
MB23	10,8	115	159	2	137	12	110,5	12
MBL24	7,7	120	151	2	135	14	115	12
MB24	10,5	120	164	2	138	14	115	12
MB25	11,8	125	170	2	148	14	120	12
MBL26	8,7	130	161	2	145	14	125	12
MB26	11,3	130	175	2	149	14	125	12
MB27	14,4	135	185	2	160	14	130	14

1) The dimension E can be used as a minimum dimension for the slot width in shafts.

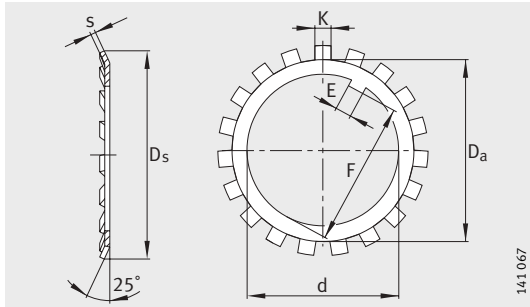

MB, MBL

Dimension table (continued) · Dimensions in mm								
Designation	Mass m 100 pieces ≈ kg	Dimensions			Mounting dimensions			
		d	D _s ≈	s	D _a	E ¹⁾	F	K
MBL28	10,9	140	171	2	155	16	135	12
MB28	14,2	140	192	2	160	16	135	14
MB29	16,8	145	202	2	171	16	140	14
MBL30	11,3	150	188	2	170	16	145	14
MB30	15,5	150	205	2	171	16	145	14
MB31	20,9	155	212	2,5	182	16	147,5	16
MBL32	16,2	160	199	2,5	180	18	154	14
MB32	22,2	160	217	2,5	182	18	154	16
MB33	24,1	165	222	2,5	193	18	157,5	16
MBL34	17	170	211	2,5	190	18	164	16
MB34	24,7	170	232	2,5	193	18	164	16
MBL36	18	180	221	2,5	200	20	174	16
MB36	26,8	180	242	2,5	203	20	174	18
MBL38	20,5	190	231	2,5	210	20	184	16
MB38	27,8	190	252	2,5	214	20	184	18
MBL40	21,4	200	248	2,5	222	20	194	18
MB40	29,3	200	262	2,5	226	20	194	18
MB44	40	220	292	3	250	24	213	20
MB48	40	240	312	3	270	24	233	20
MB52	60	260	342	3	300	28	253	24
MB56	62	280	362	3	320	28	273	24

¹⁾ The dimension E can be used as a minimum dimension for the slot width in shafts.



Retaining brackets

With hexagon head cap screw

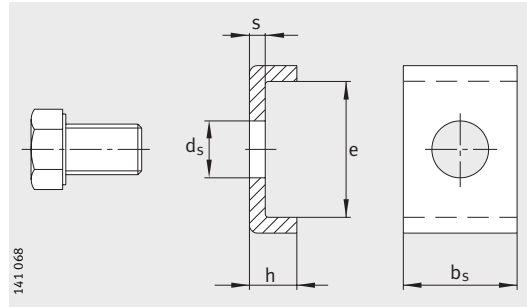

Dimension table · Dimensions in mm										
Designation		Tightening torque Nm	Mass m ≈kg	Dimensions					Mounting dimensions Shaft slot	
Retaining bracket Complete	Hexagon head cap screw ¹⁾			s	b _s	h	d _s	e	b _w	t
MS3044	M6X10	10	0,026	4	20	12	7	13,5	22	9
MS3144	M8X16	25	0,038	4	20	12	9	22,5	22	9
MS3048	M8X16	25	0,035	4	20	12	9	17,5	22	9
MS3152	M10X20	51	0,056	4	24	12	11	25,5	26	9
MS3056	M8X16	25	0,04	4	24	12	9	17,5	26	9
MS3060	M8X16	25	0,043	4	24	12	9	20,5	26	9
MS3160	M10X20	51	0,059	4	24	12	12	30,5	26	9
MS3064	M8X16	25	0,057	5	24	15	9	21	26	10
MS3164	M10X20	51	0,074	5	24	15	12	31	26	10
MS3168	M12X22	87	0,115	5	28	15	14	38	30	10
MS3072	M8X16	25	0,064	5	28	15	9	20	30	10
MS3076	M10X20	51	0,076	5	28	15	12	24	30	10
MS3176	M12X22	87	0,115	5	32	15	14	40	34	10
MS3180	M16X25	215	0,154	5	32	15	18	45	34	10
MS3084	M10X20	51	0,085	5	32	15	12	24	34	10
MS3088	M12X22	87	0,1	5	32	15	14	28	34	10
MS3188	M16X25	215	0,163	5	36	15	18	43	38	10
MS3096	M12X22	87	0,109	5	36	15	14	28	38	12
MS3196	M16X25	215	0,177	5	36	15	18	53	38	12
MS31/500	M16X25	215	0,178	5	40	15	18	45	42	12

¹⁾ Up to M16 thread: self-retaining screw.

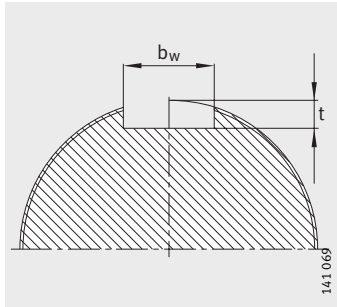

Shaft

Dimension table (continued) · Dimensions in mm										
Designation		Tightening torque	Mass m ≈ kg	Dimensions					Mounting dimensions Shaft slot	
Retaining bracket Complete	Hexagon head cap screw ¹⁾			s	b _s	h	d _s	e	b _w	t
MS30/530	M16X25	215	0,223	7	40	21	18	34	42	14
MS31/530	M20X40	430	0,347	7	40	21	22	51	42	14
MS30/560	M16X25	215	0,212	7	40	21	18	29	42	14
MS31/560	M20X40	430	0,38	7	45	21	22	54	47	14
MS30/630	M16X25	215	0,244	7	45	21	18	34	47	14
MS31/630	M20X40	430	0,426	7	50	21	22	61	52	14
MS30/670	M16X25	215	0,257	7	45	21	18	39	47	14
MS31/670	M20X40	430	0,439	7	50	21	22	66	52	15
MS30/710	M16X25	215	0,279	7	50	21	18	39	52	15
MS31/710	M24X45	740	0,58	7	55	21	26	69	57	15
MS30/750	M16X25	215	0,301	7	55	21	18	39	57	15
MS31/750	M24X45	740	0,614	7	60	21	26	70	62	15
MS30/850	M20X40	430	0,426	7	60	21	22	44	62	15
MS31/850	M24X45	740	0,679	7	70	21	26	71	72	16
MS31/900	M24X45	740	0,698	7	70	21	26	76	72	16
MS30/950	M20X40	430	0,433	7	60	21	22	46	62	16
MS31/950	M24X45	740	0,706	7	70	21	26	78	72	16
MS30/1000	M20X40	430	0,449	7	60	21	22	51	62	16
MS31/1000	M24X45	740	0,744	7	70	21	26	88	72	16
MS30/1500	M20X40	430	0,466	7	60	21	22	56	62	16

¹⁾ Up to M16 thread: self-retaining screw.
From M20 thread: standardised hexagon head cap screw with retainer.



FAG



Arcanol rolling bearing greases

Arcanol rolling bearing greases

	Page
Product overview Arcanol rolling bearing greases	1358
Features Containers.....	1359
Arcanol greases.....	1360



Product overview Arcanol rolling bearing greases

Arcanol
rolling bearing greases



155 253

Arcanol rolling bearing greases

Features FAG developed the range of Arcanol rolling bearing greases from a large number of lubricants. These greases offer very good preconditions for favourable running behaviour of bearings and a long life and high operational reliability of the bearing arrangement.

The areas of application of Arcanol greases were determined under widely differing operating conditions and with rolling bearings of all types by means of modern testing methods and testing systems.

Finely graduated range The range is graduated such that almost all areas of application can be covered to an optimum extent using fourteen rolling bearing greases.

The table on page 1360 shows the physical data for these greases and information on the areas of application.

Variants for automatic or manual grease lubrication For grease lubrication, we supply automatic lubricators of the variants COMPACT, CHAMPION und CONCEPT6, filled with Arcanol greases from FAG.

For manual lubrication, we supply a grease gun, comprising a manual grease gun ARCA.GREASE-GUN and the matching armoured tube ARCA.GREASE-GUN.HOSE.

Containers Arcanol rolling bearing greases are available in tubes, cartridges, cans, buckets, hobbocks and drums. The following table shows which grease grades are supplied in which containers.

Grease container sizes

Arcanol grease	Tube			Cart-ridge 400 g	Can 1 kg	Bucket		Hob- bock 25 kg	Drum 180 kg
	20 g	70 g	250 g			5 kg	10 kg		
MULTITOP	–	–	●	●	●	●	●	●	●
MULTI2	●	–	●	●	●	●	●	●	●
MULTI3	–	–	●	●	●	●	●	●	●
LOAD220	–	–	–	–	●	–	●	●	●
LOAD400	–	–	–	●	●	●	●	●	●
LOAD1 000	–	–	–	–	–	●	–	●	●
TEMP90	●	–	–	●	●	●	–	●	●
TEMP110	–	–	–	●	●	–	–	–	–
TEMP120	–	–	–	–	●	●	–	●	–
TEMP200	–	●	–	–	●	–	–	–	–
SPEED2,6	–	–	●	–	●	–	–	●	–
VIB3	–	–	–	–	●	●	–	●	–
BIO2	–	–	–	●	●	–	●	●	●
FOOD2	–	–	–	●	●	–	●	●	●

Other container sizes by agreement.



Arcanol rolling bearing greases

Arcanol greases

The chemical/physical characteristics of the greases, their principal characteristic and application examples are shown in the table. Ordering examples for the greases are listed below.

Arcanol rolling bearing greases

Designation	Thickener	Base oil viscosity at +40 °C mm ² /s	Consistency NLGI class
MULTITOP	Lithium soap with EP additives	85	2
MULTI2	Lithium soap	ISO VG 100	2
MULTI3	Lithium soap	80	3
LOAD220	Lithium/calcium soap with EP additives	ISO VG 220	2
LOAD400	Lithium/calcium soap with EP additives	400	2
LOAD1 000	Lithium/calcium soap with EP additives	ISO VG 1000	2
TEMP90	Calcium polycarbamide with EP additives	130	2
TEMP110	Lithium complex soap	ISO VG 150	2
TEMP120	Polycarbamide with EP additives	ISO VG 460	2
TEMP200	PTFE	400	2
SPEED2,6	Polycarbamide	ISO VG 22	2 to 3
VIB3	Lithium complex soap with EP additives	170	3
BIO2	Lithium/calcium soap	58	2
FOOD2	Aluminium complex soap	192	2

Ordering examples

- ARCANOL-MULTITOP-5KG
- ARCANOL-MULTI2-20G
- ARCANOL-MULTI3-25KG
- ARCANOL-LOAD220-1KG
- ARCANOL-LOAD400-400G
- ARCANOL-LOAD1000-5KG
- ARCANOL-TEMP90-180KG
- ARCANOL-TEMP110-400G

Operating temperature °C	Continuous limit temperature °C	Principal characteristic	Application examples
-40 +150	+80	Universal grease for ball and roller bearings at increased speeds, high load, low and high temperatures	Rolling mills, construction machinery, automotive, spinning and grinding spindles
-30 +140	+75	Universal grease for ball bearings D ≤ 62 mm	Small electric motors, agricultural and construction machinery, household appliances
-30 +140	+75	Universal grease for ball bearings D > 62 mm	Large electric motors, agricultural and construction machinery, fans
-20 +140	+80	Special grease for ball and roller bearings at high loads, wide speed range, high humidity	Rolling mill equipment, rail vehicles
-25 +140	+80	Special grease for ball and roller bearings at very high loads, moderate temperature, low speed	Mining machinery, construction machinery
-20 +140	+80	Special grease for ball and roller bearings at very high loads, moderate temperature, low speed	Mining machinery, construction machinery preferably under shock load and in large bearings
-40 +160	+90	Special grease for ball and roller bearings at high temperature, high loads	Couplings, electric motors, automotive
-40 +160	+110	Special grease for ball and roller bearings at high temperature, high speeds	Electric motors, automotive
-35 +180	+120	Special grease for ball and roller bearings at high temperature, high loads	Continuous casting machines
-40 +260	+200	Special grease for ball and roller bearings at very high temperature, for chemically aggressive environments	Track rollers in baking machinery, piston pins in compressors, kiln trucks, chemical plant
-50 +120	+80	Special grease for ball bearings at very high speed, low temperature	Machine tools, instruments
-30 +150	+90	Special grease for ball and roller bearings at high temperature, high loads, oscillating motion	Blade adjusters in rotors in wind turbines, packaging machinery
-30 +120	+80	Special grease for ball and roller bearings	In environmentally hazardous applications
-30 +120	+70	Special grease for ball and roller bearings	In applications with food contact; H1 to USDA

Ordering examples – continued

- ARCANOL-TEMP120-25KG
- ARCANOL-TEMP200-70G
- ARCANOL-SPEED2,6-250G
- ARCANOL-VIB3-25KG
- ARCANOL-BIO2-1KG
- ARCANOL-FOOD2-10KG



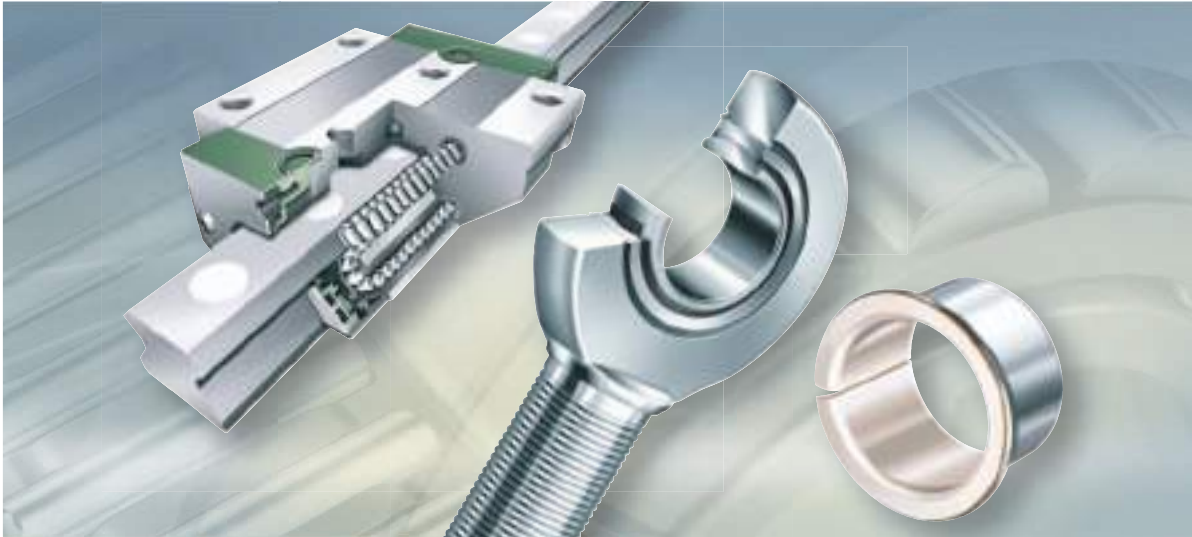

Other products

Slewing rings
Thin section bearings
Permaglide[®] plain bearings
ELGES spherical plain bearings, plain bushes, rod ends
Linear guidance systems
Equipment and services for
the mounting and maintenance of rolling bearings

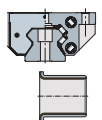



Slewing rings

Four point contact bearings
Crossed roller bearings

Slewing rings

	Page
Product overview Slewing rings.....	1366
Features Four point contact bearings	1367
Crossed roller bearings.....	1367

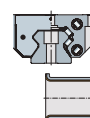

Product overview Slewing rings

Four point contact bearings Light series 20

VLA20



VLU20

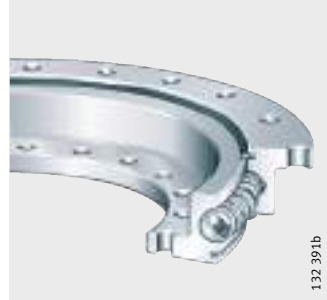

Standard series 20, 25

VSI20
VSI25

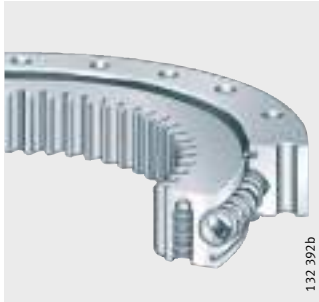

VSU20
VSU25

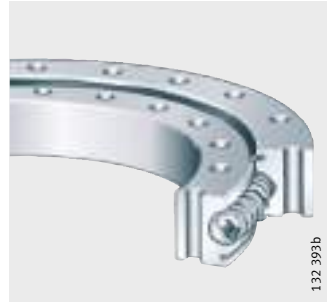

Crossed roller bearings Standard series 14

XSA14

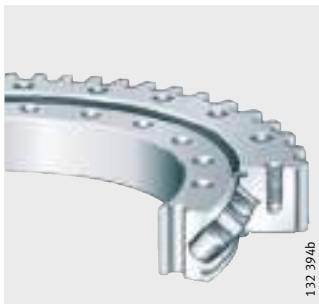

XSI14

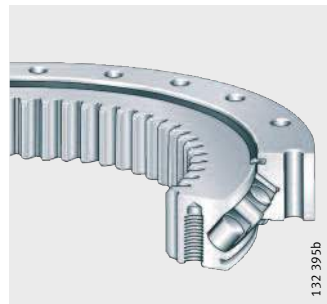

XSU14



Slewing rings

Features INA slewing rings are known worldwide as premium products in the field of rolling bearing technology. These machine elements have proved themselves many times over; they have high load carrying capacity, a versatile range of applications and are highly cost-effective. Due to their design, a single bearing can reliably support radial, axial and tilting moment loads. It is therefore possible in many cases to replace bearing arrangements comprising a combination of radial and axial bearings by a single bearing. This reduces, in some cases considerably, the costs and work required in the design of the adjacent construction and the fitting of bearings.

Slewing rings are sealed on both sides, lubricated with a high quality grease, can be relubricated via lubrication nipples and are particularly easy to fit. The bearing rings are supplied without gear teeth or, in order to achieve simple drive solutions, are available with external or internal gear teeth.

INA slewing rings are designed as four point contact bearings and crossed roller bearings.

Four point contact bearings

Four point contact bearings are available with external teeth, internal teeth or without teeth as well as in the light series 20 and the standard series 20 and 25.

These slewing rings without preload are robust and proven under very demanding operation; they place only slight demands on the flatness and perpendicularity of the adjacent construction.

They are suitable for applications with low requirements for accuracy and rigidity of the bearing arrangement, for example in simple metalworking machines, wind power equipment and construction machinery.

Crossed roller bearings

Crossed roller bearings are available with external teeth, internal teeth and without teeth in the standard series 14 as well as in the series XA, XI, XU.

These preloaded slewing rings can support higher loads than four point contact bearings. They have proved themselves particularly where bearings are subjected to high radial forces and moderate axial and tilting moment loads.

They are suitable for applications with uniform running free from stick-slip, low rotational resistance and high requirements for axial and radial runout accuracy and rigidity, for example in robots, handling systems and machine tools.

Catalogue: Slewing rings

The standard range is described comprehensively in Catalogue 404 and the CD and online versions of *medias*[®] *professional*.

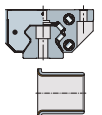



Thin section bearings

Thin section bearings

	Page
Product overview Thin section bearings	1370
Features Deep groove ball bearings, four point contact bearings, angular contact ball bearings	1371

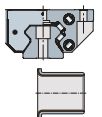

Product overview Thin section bearings

Deep groove ball bearings
Type C



Four point contact bearings
Type X



Angular contact ball bearings
Type E



Thin section bearings

Features Thin section bearings are high precision products with very little running noise and high load carrying capacity. These bearings are available in three different designs with extremely small, predominantly square cross-sections. Within each series, the cross-section remains constant even at higher shaft and housing bore diameters. The bearings are therefore also described as Constant Section (CS) bearings. This feature distinguishes thin section bearings from the conventional bearings that are described in standardised ISO series.

In this way, a larger cross-section can be selected in a graduated way and thus a bearing with high load carrying capacity can be used without the need to increase the shaft diameter. Thin section bearings can thus be used to achieve extremely light and compact designs.

Deep groove ball bearings, four point contact bearings, angular contact ball bearings

Thin section bearings are available as deep groove ball bearings (C), four point contact bearings (X) and as angular contact ball bearings (E). Each of these designs is available in various series. The series correspond to the cross-section sizes. The balls are matched to the series.

Deep groove ball bearings can support axial loads in both directions as well as radial loads; under axial load, a contact angle $\alpha > 0^\circ$ is adopted.

Four point contact bearings can support axial loads in both directions as well as radial loads; they thus act as double row angular contact ball bearings.

Angular contact ball bearings can be filled with an optimised number of balls and have a contact angle of 30° . They can support considerably higher radial loads than deep groove ball bearings or four point contact bearings and can support axial loads in one direction. For particular requirements, angular contact ball bearings are also available as matched pairs of bearings. These combinations then have significantly higher rigidity and load carrying capacity than individual bearing solutions.

Thin section bearings are available in open and sealed designs. The seals are made from synthetic rubber (NBR) with a steel insert. Sealed bearings are greased. For extreme operating conditions, special lubricants are available. Cages are made from brass or plastic.

In addition to the standard tolerance class PL1, classes PL3 and PL6 are also available (with increasingly tighter tolerances).

Catalogue: Thin section bearings The standard range is described comprehensively in Catalogue 575.

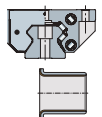

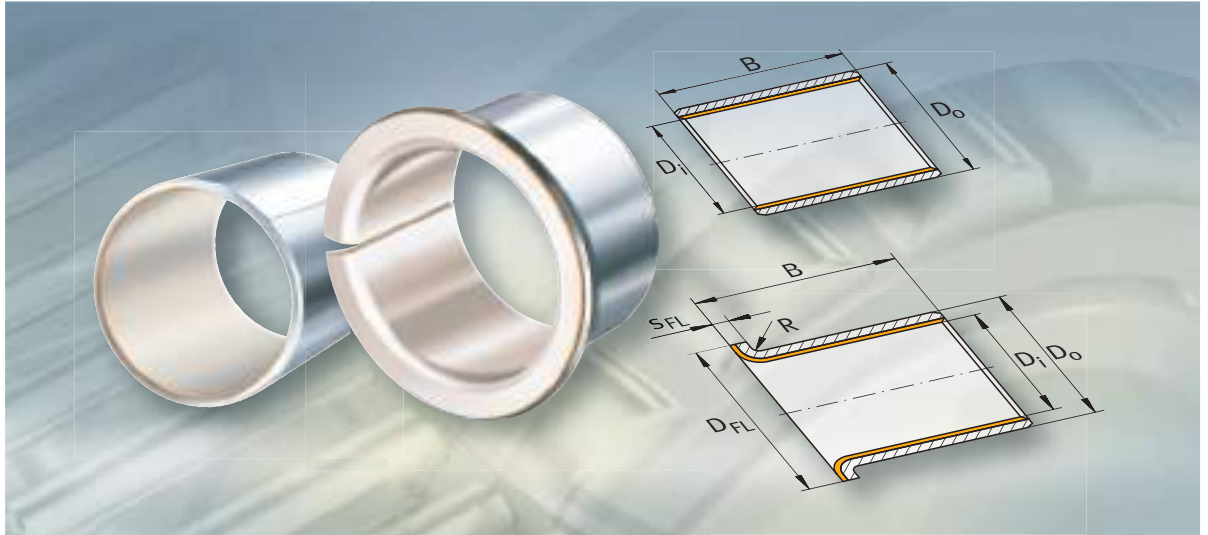

Permaglide[®] plain bearings

Maintenance-free plain bearing material P1

Low-maintenance plain bearing material P2

Bushes

Flanged bushes

Thrust washers

Strips

Permaglide® plain bearings

	Page
Product overview Permaglide® plain bearings	1374
Features Maintenance-free Permaglide® plain bearing material P1.....	1375
Low-maintenance Permaglide® plain bearing material P2	1378
Special designs, linear plain bearings	1381

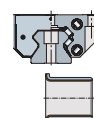

Permaglide® is a registered trademark
and product of KS Gleitlager GmbH, St. Leon-Rot

Product overview Permaglide® plain bearings

Bushes
P1 maintenance-free
P2 low-maintenance

PAP..-P10, PAP..-P11
PAP..-P14, PAPZ...-P10



PAP..-P20



Flanged bushes
P1 maintenance-free

PAF..-P10, PAF..-P11
PAF..-P14



Thrust washers
P1 maintenance-free
P2 low-maintenance

PAW..-P10
PAW..-P14



PAW..-P20

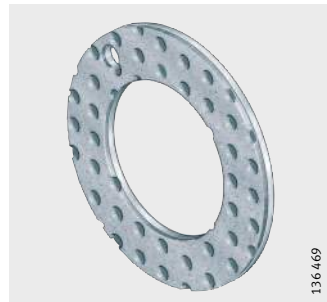

Strips
P1 maintenance-free
P2 low-maintenance

PAS..-P10, PAS..-P11
PAS..-P14

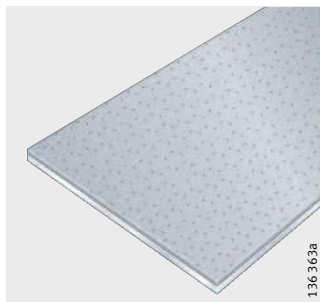

PAS..-P20

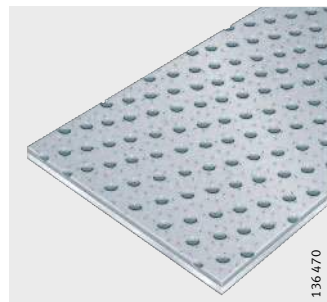

Permaglide® plain bearings

Features

Permaglide® plain bearings are bearings for very small radial or axial design envelopes. These products are available as bushes, flanged bushes, thrust washers and strips and in two material groups. The bushes are available in metric sizes and in inch sizes. Bushes, washers and strips are made from the maintenance-free Permaglide® P1 or the low-maintenance P2.

Flanged bushes are made from maintenance-free Permaglide® P1.

Caution!

Some P1 and P2 materials contain lead (Pb).
Materials containing lead should not be allowed to come into contact with foodstuffs or pharmaceutical products.

Catalogue: Permaglide® plain bearings

The complete Permaglide® standard range is described comprehensively in Catalogue 706 and the CD and online version of *medias® professional*.

Maintenance-free Permaglide® plain bearing material P1

Permaglide® P1 is maintenance-free and suitable for dry running. It can be used for rotary and oscillating motion as well as for short stroke linear motion.

The low-wear material has good sliding characteristics, a low coefficient of friction and high resistance to chemicals. It does not absorb water (highly resistant to swelling), does not tend to weld to metal and is also suitable for hydrodynamic operation.

The maintenance-free Permaglide® materials are available in the variants P10, P11 and P14.

P141 is available by agreement, page 1376.

Permaglide® P10

The variant P10 has a steel backing, *Figure 1*.

- ① Running-in layer: polytetrafluorethylene (PTFE) and lead (Pb), 0,01 mm to 0,03 mm thick
- ② Sliding layer: porous bronze layer, filled with PTFE/Pb, 0,2 mm to 0,35 mm thick
- ③ Steel backing
- ④ Surface protection for steel backing, end faces and butt joint faces: tin, approx. 0,002 mm thick

Figure 1
Permaglide® P10

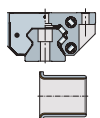
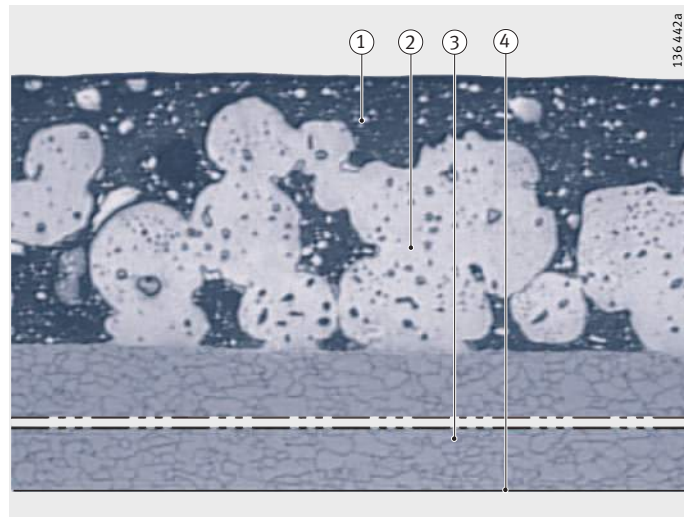

Permaglide® plain bearings

Permaglide® P11

In P11, the backing is made from bronze, *Figure 2*. Plain bearings made from this material have high corrosion resistance and thermal conductivity and are antimagnetic.

- ① Running-in layer: polytetrafluorethylene (PTFE) and lead (Pb), 0,01 mm to 0,03 mm thick
- ② Sliding layer: porous bronze layer, filled with PTFE/Pb, 0,2 mm to 0,35 mm thick
- ③ Bronze backing

Figure 2
Permaglide® P11

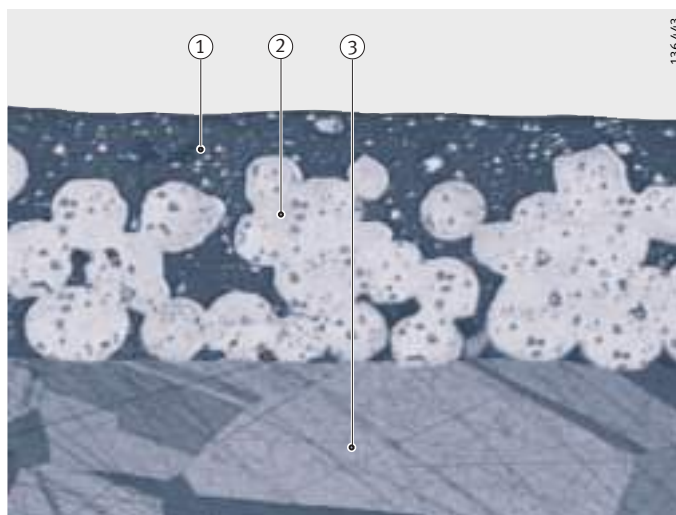

Permaglide® P14

P14 has a steel backing but is free from lead, *Figure 3*.

- ① Running-in layer: polytetrafluorethylene (PTFE) and zinc sulphide (ZnS), 0,01 mm to 0,03 mm thick
- ② Sliding layer: porous bronze layer, filled with PTFE/ZnS, 0,2 mm to 0,35 mm thick
- ③ Steel backing
- ④ Surface protection for steel backing, end faces and butt joint faces: tin, approx. 0,002 mm thick

Figure 3
Permaglide® P14

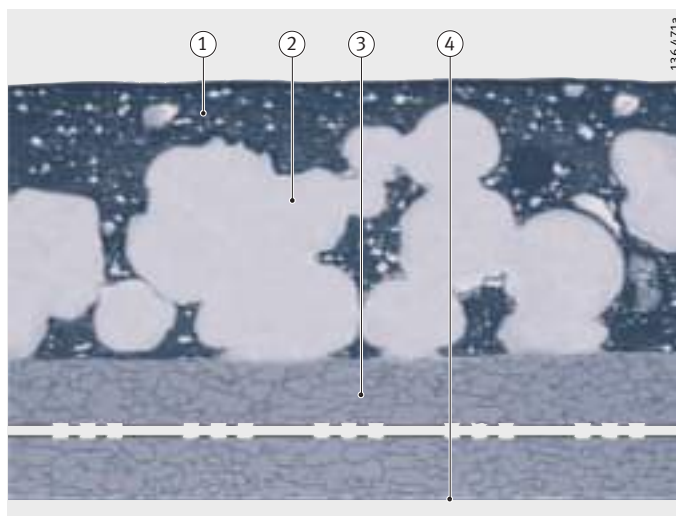

Special design

Available by agreement and as a special design is the lead-free Permaglide® P141. This material is similar in structure to P14 but has wear-inhibiting additives.

The running-in layer and sliding layer are resistant to swelling and the temperature range extends from -60 °C to $+260\text{ °C}$.

All maintenance-free P1 materials (except for P11) can also be supplied with increased anti-corrosion protection.

Technical data The important mechanical and physical characteristics of the maintenance-free P1 plain bearing materials are shown in the table.

Data

Characteristics				
Maximum pv value for dry running	Continuous operation	pv	1,8	N/mm ² · m/s
	For short periods		3,6	N/mm ² · m/s
Permissible specific bearing load	Static	p _{max}	250	N/mm ²
	Very low sliding speed		140	N/mm ²
	Rotating, oscillating		56	N/mm ²
Permissible sliding speed	Dry running	v _{max}	2	m/s
	Hydrodynamic operation		>2	m/s
Permissible operating temperature	–	ϑ	–200 to +280	°C
Coefficient of thermal expansion	Steel backing	α _{St}	11 · 10 ^{–6}	K ^{–1}
	Bronze backing	α _{Bz}	17 · 10 ^{–6}	K ^{–1}
Coefficient of thermal conductivity	Steel backing	λ _{St}	>42	W (m · K) ^{–1}
	Bronze backing	λ _{Bz}	>70	W (m · K) ^{–1}
Relative electrical resistance after running-in		R _{rel min}	> 1	Ω · cm ²

Product overview/dimensions The available standard dimension ranges for bushes, washers and strips made from P1 material are given in the table.

Product and size range

Plain bearings made from P1 material	Designation	For shafts to/from and dimensions
Bushes	PAP...P10	2 mm to 300 mm
	PAPZ...P10	³ / ₁₆ " to 2"
	PAP...P11	4 mm to 100 mm
	PAP...P14	2 mm to 300 mm
Flanged bushes	PAF...P10	6 mm to 40 mm
	PAF...P11	6 mm to 40 mm
	PAF...P14	6 mm to 40 mm
Thrust washers	PAW...P10	10 mm to 62 mm
	PAW...P11	Available by agreement
	PAW...P14	10 mm to 62 mm
Strips	PAS...P10	Length 500 mm, widths from 180 mm to 250 mm, thicknesses from 0,5 mm to 3,06 mm
	PAS...P11	Length 500 mm, widths from 160 mm to 180 mm, thicknesses from 1 mm to 2,5 mm
	PAS...P14	Length 500 mm, widths from 180 mm to 250 mm, thicknesses from 0,5 mm to 3,06 mm

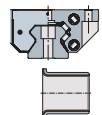

Permaglide® plain bearings

Low-maintenance Permaglide® plain bearing material P2

Permaglide® P2 is a low-maintenance, low-wear material with good damping characteristics and long relubrication intervals. It can be used for rotary and oscillating motion, has good resistance to edge loading and is highly resistant to shock loads.

Low-maintenance Permaglide® materials are available in the variants P20, P21, P22, P23 and P25.

P21, P22, P23 and P25 are available by agreement.

Permaglide® P20

The variant P20 is ready-to-fit and has lubrication pockets, *Figure 4*.

Permaglide® P21

This material has lubrication pockets and a machining allowance, *Figure 4*. The sliding layer is approximately 0,15 mm thicker than in P20 and can therefore be machined subsequently by swarf-forming methods. Misalignment inaccuracies can therefore be compensated or internal clearances with tighter tolerances can be achieved.

- ① Sliding layer: polyvinylidene fluoride (PVDF), polytetrafluorethylene (PTFE) and lead (Pb), 0,05 mm to 0,1 mm thick
- ② Bronze intermediate layer: 0,2 mm to 0,35 mm thick
- ③ Steel backing
- ④ Surface protection: tin, approx. 0,002 mm thick
- ⑤ P20 and P21 with lubrication pockets
P21 with machining allowance s_4 of approx. 0,15 mm

Figure 4
Permaglide® P20, P21

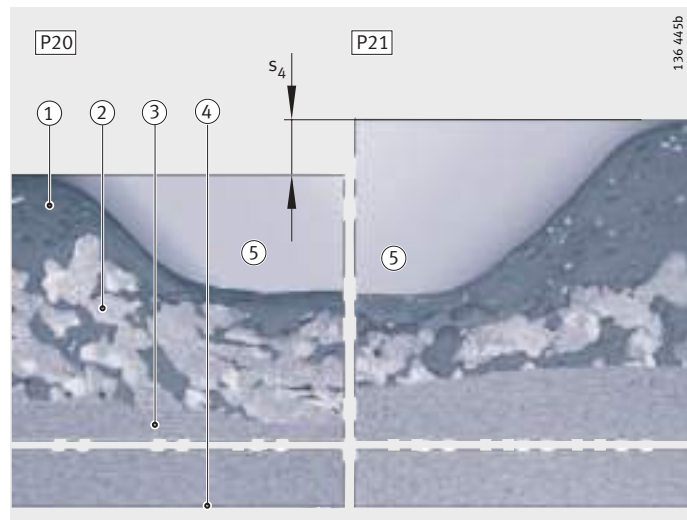

Permaglide® P22

P22 does not have lubrication pockets but does have a machining allowance, *Figure 5*. The sliding layer is approximately 0,15 mm thicker than in P20 and can therefore be machined subsequently by swarf-forming methods. Misalignment inaccuracies can therefore be compensated or internal clearances with tighter tolerances can be achieved.

Permaglide® P23

The variant P23 is ready-to-fit and does not have lubrication pockets, *Figure 5*.

- ① Sliding layer: polyvinylidene fluoride (PVDF), polytetrafluorethylene (PTFE) and lead (Pb), 0,05 mm to 0,1 mm thick
 - ② Bronze intermediate layer: 0,2 mm to 0,35 mm thick
 - ③ Steel backing
 - ④ Surface protection: tin, approx. 0,002 mm thick
- P22 and P23 without lubrication pockets
P22 with machining allowance s_4 of approx. 0,15 mm

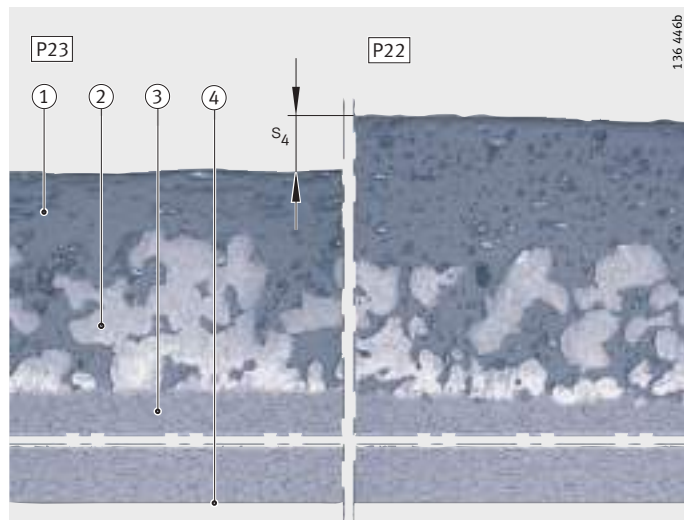
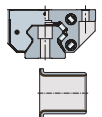

Figure 5
Permaglide® P23, P22

Special design

Available by agreement and as a special design is Permaglide® P25. This material is ready-to-fit, has lubrication pockets and is highly resistant to corrosion due to the bronze backing.

All low-maintenance P2 materials (except for P25) can also be supplied with increased anti-corrosion protection.



Permaglide® plain bearings

Technical data The important mechanical and physical characteristics of the low-maintenance P2 plain bearing materials are shown in the table.

Data

Characteristics				
Maximum pv value		pv	3	N/mm ² · m/s
Permissible specific bearing load	Static	p _{max}	250	N/mm ²
	Very low sliding speed		140	N/mm ²
	Rotating, oscillating		70	N/mm ²
Permissible sliding speed	–	v _{max}	3	m/s
	Hydrodynamic operation		>3	m/s
Permissible operating temperature	Continuous operation	ϑ	–40 to +110 °C	
	For short periods	ϑ _{max}	+140	°C
Coefficient of thermal expansion	Steel backing	α _{St}	11 · 10 ^{–6}	K ^{–1}
Coefficient of thermal conductivity	Steel backing	λ _{St}	<4	W (m · K) ^{–1}
Coefficient of friction		μ	0,02 to 0,2	

Product overview/dimensions The available standard dimension ranges for bushes, washers and strips made from P2 material are given in the table.

Product and size range

Plain bearings made from P2 material	Designation	For shafts to/from and dimensions
Bushes	PAP..-P20	8 mm to 100 mm
Thrust washers	PAW..-P20	12 mm to 52 mm
Strips	PAS..-P20	Length to 500 mm, widths from 180 mm to 250 mm, thicknesses from 0,99 mm to 2,46 mm

Special designs, linear plain bearings

In addition to the catalogue range, there are numerous special designs, *Figure 7*, page 1382:

- made from any Permaglide® plain bearing material
- with different dimensions from the catalogue products
- as combined components ①, ②
 - pressed into rings
 - with plastic moulded parts
- in different shapes ⑦, ⑭
 - bushes with windows and holes ③, ⑤
 - bushes with stamped oil grooves ④, ⑤
 - stamped components ⑬, ⑮, ⑯
 - ball cups ⑩, ⑪, ⑫
 - bearing shells ⑰, ⑱
- with the sliding layer on the outside ⑧, ⑨
- with different butt joint geometries ⑨.

The picture shows a small selection of special components already produced.

Special designs can be made in the following sizes:

- outside diameters of the bush between 3 mm and 305 mm (in special cases up to 800 mm)
- strip widths up to 205 mm
- thicknesses from 0,5 mm to 3,06 mm.

Caution! The feasibility of special designs should be checked as early as possible. This applies to the geometry and also to the costs.

Permaglide® linear plain bearings

Permaglide® linear plain bearings PAB comprise an outer ring with pressed-in Permaglide® bushes PAP..-P20, *Figure 6*, ①. The variant PABO has a segment cut out for supported shafts.

Permaglide® linear plain bearing units PAGH and PAGBA comprise a housing and a pressed-in Permaglide® linear plain bearing PAB or PABO, *Figure 6*, ②.

Catalogue: Track roller and shaft guidance systems

Comprehensive information on Permaglide® linear plain bearings is given in Catalogue 801 and in *medias® professional*.



Figure 6
① Permaglide®
linear plain bearing PAB..-PP-AS
② Permaglide®
linear plain bearing unit
PAGBAO..-PP-AS

Permaglide® plain bearings – special designs

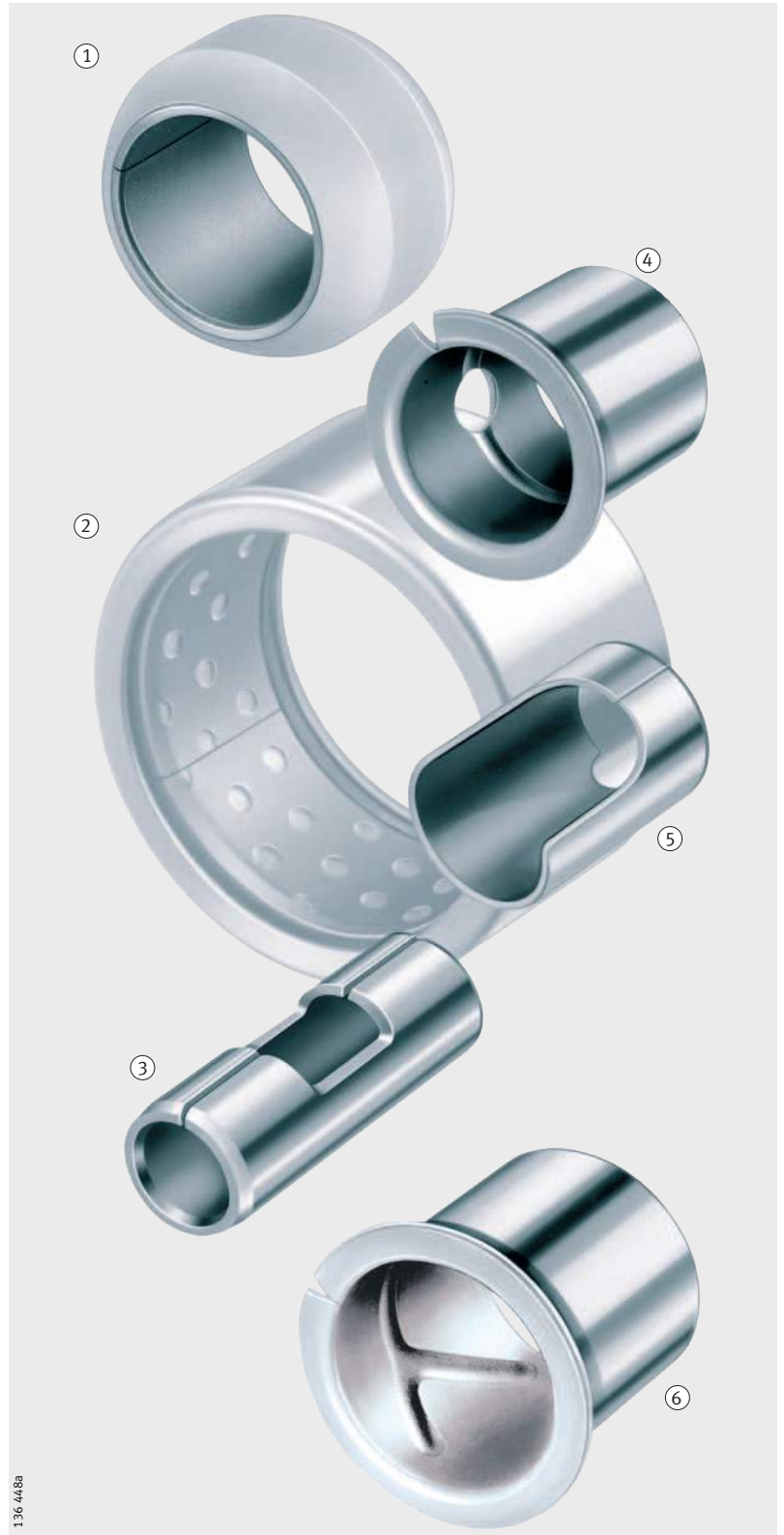

Figure 7
Special designs
Permaglide® plain bearings



136.447a

ELGES Spherical plain bearings, plain bushes, rod ends

	Page
Product overview	Maintenance-free spherical plain bearings, cylindrical plain bushes 1386
Features	Sliding layers 1387
	Radial spherical plain bearings
	⊗ Radial large spherical plain bearings 1389
	Angular contact spherical plain bearings 1389
	Axial spherical plain bearings
	⊗ Axial large spherical plain bearings 1389
	Cylindrical plain bushes 1389
Product overview	Spherical plain bearings requiring maintenance 1390
Features	Radial spherical plain bearings 1391
	Angular contact spherical plain bearings 1391
	Axial spherical plain bearings 1391
Product overview	Maintenance-free rod ends 1392
Features	Rod ends with internal thread 1393
	Rod ends with external thread 1393
Product overview	Rod ends requiring maintenance 1394
Features	Rod ends with internal thread 1395
	Rod ends with external thread 1395
Product overview	Hydraulic rod ends 1396
Features	Hydraulic rod ends with thread clamping 1397
	Hydraulic rod ends with welding face 1397

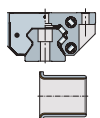

Product overview Maintenance-free spherical plain bearings, cylindrical plain bushes

Radial spherical plain bearings
Unsealed or lip seals on both sides

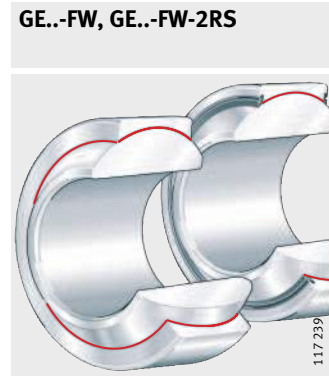
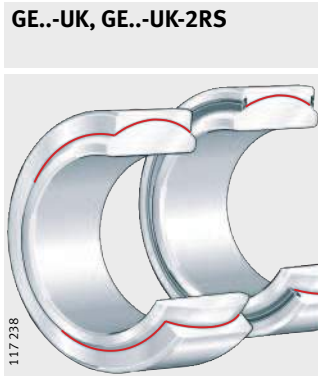

X-life
Radial and axial large spherical plain bearings
Unsealed or lip seals on both sides

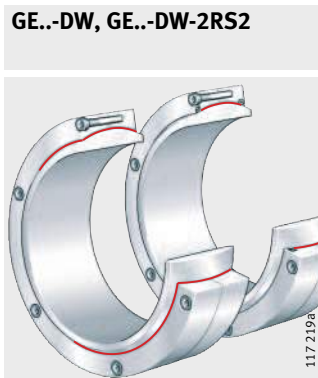

Angular contact spherical plain bearings, cylindrical plain bushes
Unsealed



Radial spherical plain bearings
Dimension series K, unsealed



Maintenance-free spherical plain bearings, cylindrical plain bushes

Features

Maintenance-free spherical plain bearings are used where:

- there are particular requirements on bearing life under maintenance-free operation
- for reasons of lubrication, bearings with a metallic sliding contact surface are not suitable, for example under unilateral load.

Spherical plain bearings allow spatial adjustment movements and, depending on the bearing type, are preferably used to support radial, combined or axial loads.

Spherical plain bearings, plain bushes, rod ends: catalogue

The standard range is described comprehensively in Catalogue 238 and the CD and online version of *medias*[®] professional.

Sliding layers

Maintenance-free spherical plain bearings have special sliding layers based on PTFE (polytetrafluoroethylene).

In descending order of performance, these are:

- ELGOGLIDE[®] – the highest performance sliding layer, *Figure 1*
- PTFE composite material, *Figure 2*, page 1388
- PTFE-bronze film, *Figure 3*, page 1388.

These materials form the slideway of the outer ring or the shaft locating washer. They transmit the forces occurring and provide lubrication – the bearings must not be lubricated in any other way.

ELGOGLIDE[®]

The sliding layer comprises 0,5 mm thick ELGOGLIDE[®], is embedded in synthetic resin and attached by a high strength bond to the support body, *Figure 1*.

The flow behaviour of the sliding layer is – in combination with the support body – almost negligible even under very high load.

The adhesive bond is resistant to moisture and does not undergo swelling.

- ① PTFE fabric, comprising Teflon[®] and supporting fibres
- ② Resin matrix
- ③ Supporting fibres
- ④ Steel substrate
- ⑤ Adhesive bond

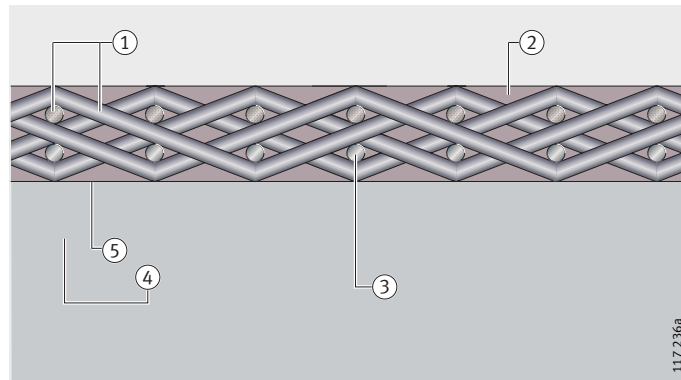
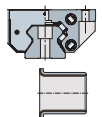

Figure 1
ELGOGLIDE[®] – cross-section



Maintenance-free spherical plain bearings, cylindrical plain bushes

PTFE composite material

PTFE composite material comprises sheet steel with bronze attached by sintering and embedded PTFE compound, *Figure 2*.

- ① PTFE compound
- ② Sintered bronze
- ③ Sheet steel

Figure 2
PTFE composite material – cross-section

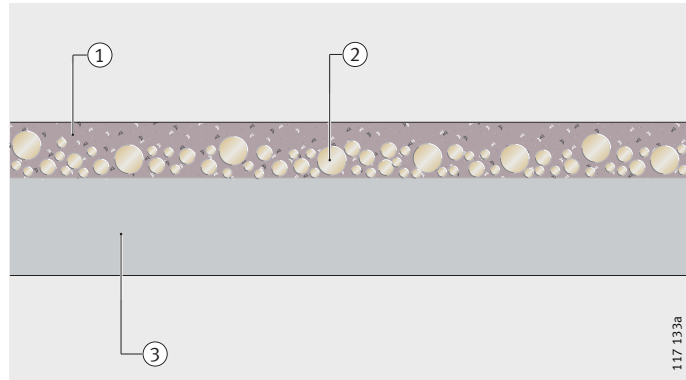



PTFE-bronze film

PTFE-bronze film (metal lattice material) is made from high strength bronze and acts as a stabiliser for the sintered PTFE compound, *Figure 3*.

- ① PTFE compound
- ② Substrate
- ③ Bronze

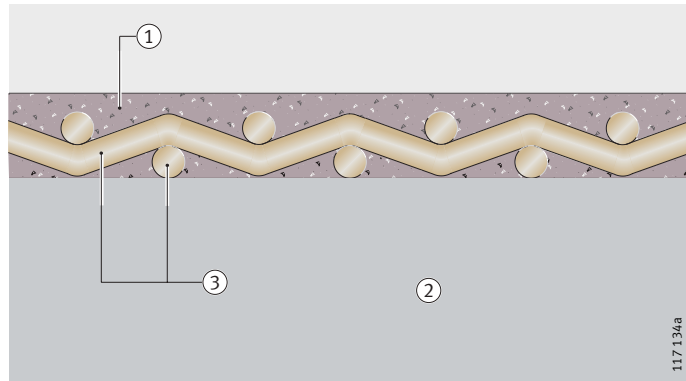
Figure 3
PTFE-bronze film – cross-section



Radial spherical plain bearings
 **Radial large spherical plain bearings**

Radial spherical plain bearings comprise inner and outer rings with maintenance-free sliding layers made from ELGOGLIDE[®], PTFE composite material or PTFE-bronze film.
 Sealed spherical plain bearings are protected by lip seals against contamination and water spray.
 These bearings have the suffix 2RS or 2RS2.
 Radial large spherical plain bearings from d = 320 mm are X-life bearings.

Series, sliding layer, standard

Series	Sliding layer	Standard to DIN ISO	Shaft diameter	
			from mm	to mm
GE..-UK	Composite	12 240-1, dimension series E	6	30
GE..-FW	Composite	12 240-1, dimension series E	6	25
GE..-UK-2RS	ELGOGLIDE [®]	12 240-1, dimension series E	17	300
GE..-FW-2RS	ELGOGLIDE [®]	12 240-1, dimension series G	30	280
GE..-DW	ELGOGLIDE [®]	12 240-1, dimension series C	320	1000
GE..-DW-2RS2	ELGOGLIDE [®]	12 240-1, dimension series C	320	1000
GE..-PW	PTFE-bronze film	12 240-1, dimension series K	5	30

Angular contact spherical plain bearings

Angular contact spherical plain bearings comprise inner and outer rings with ELGOGLIDE[®]. In addition to radial forces, they can also support axial forces and are suitable for alternating dynamic loads.

Series, sliding layer, standard

Series	Sliding layer	Standard to DIN ISO	Shaft diameter	
			from mm	to mm
GE..-SW	ELGOGLIDE [®]	12 240-2	25	200

Axial spherical plain bearings
 **Axial large spherical plain bearings**

Axial spherical plain bearings comprise shaft locating and housing locating washers with ELGOGLIDE[®]. They are preferably used to support axial forces and are suitable as support or base bearings.
 Axial large spherical plain bearings from d = 220 mm are X-life bearings.

Series, sliding layer, standard

Series	Sliding layer	Standard to DIN ISO	Shaft diameter	
			from mm	to mm
GE..-AW	ELGOGLIDE [®]	12 240-3	10	360

Cylindrical plain bushes

Cylindrical plain bushes comprise a steel support body with ELGOGLIDE[®]. They allow not only swivel movements but also axial movements and can support higher forces than conventional plain bearings.

Series, sliding layer, standard

Series	Sliding layer	Standard to DIN ISO	Shaft diameter	
			from mm	to mm
ZGB	ELGOGLIDE [®]	4 379 ¹⁾	30	200

¹⁾ Main dimensions only.

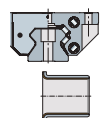

Product overview Spherical plain bearings requiring maintenance

Radial spherical plain bearings
Unsealed or lip seals on both sides

GE..-DO, GE..-DO-2RS



GE..-FO, GE..-FO-2RS

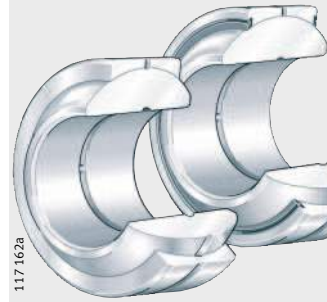

GE..-LO



GE..-HO-2RS



Unsealed, inch dimensions or dimension series K

GE..-ZO



GE..-PB



Angular contact spherical plain bearings, axial spherical plain bearings
Unsealed

GE..-SX



GE..-AX



Spherical plain bearings requiring maintenance

Features Radial spherical plain bearings

Radial spherical plain bearings comprise inner and outer rings with steel/steel or steel/bronze sliding contact surfaces and are lubricated via the inner and outer ring. They can support radial forces, transmit motion and loads with low moment levels and thus keep bending stresses away from the adjacent structure.

The bearings are particularly suitable for alternating loads with impact and shock type stresses and support axial loads in both directions.

Sealed spherical plain bearings are protected against contamination and water spray by lip seals and have the suffix 2RS.

Series, sliding contact surface, standard

Series	Sliding contact surface	Standard to DIN ISO	Shaft diameter	
			from mm	to mm
GE..-DO	Steel/steel	12 240-1, dimension series E	6	200
GE..-DO-2RS	Steel/steel	12 240-1, dimension series E	17	300
GE..-DO	Steel/steel	12 240-1, dimension series C	320	1000
GE..-FO	Steel/steel	12 240-1, dimension series G	6	12
GE..-FO-2RS	Steel/steel	12 240-1, dimension series G	15	280
GE..-LO	Steel/steel	12 240-1, dimension series W	12	320
GE..-HO-2RS	Steel/steel	–	20	80
GE..-ZO	Steel/steel	–	19,05	76,2
GE..-PB	Steel/brass	12 240-1, dimension series K	5	30

Angular contact spherical plain bearings

Angular contact spherical plain bearings comprise inner and outer rings with steel/steel sliding contact surfaces. In addition to radial forces, they can also support axial forces, are suitable for alternating dynamic loads and used, for example, as a plain bearing alternative to tapered roller bearings of series 320X to DIN 720 where loads in conjunction with small swivel angles would damage rolling bearings.

Angular contact spherical plain bearings transmit motion and loads with low moment levels and thus keep bending stresses away from the adjacent structure. They are intended for grease lubrication and are lubricated via the outer ring.

Series, sliding contact surface, standard

Series	Sliding contact surface	Standard to DIN ISO	Shaft diameter	
			from mm	to mm
GE..-SX	Steel/steel	12 240-2	25	200

Axial spherical plain bearings

Axial spherical plain bearings comprise shaft locating and housing locating washers with steel/steel sliding contact surfaces, can support axial forces and transmit support forces with low moment levels into the adjacent construction. In order to support radial forces, they can be combined with radial spherical plain bearings of dimension series E to DIN ISO 12 240-1.

The bearings are lubricated via the housing locating washer.

Series, sliding contact surface, standard

Series	Sliding contact surface	Standard to DIN ISO	Shaft diameter	
			from mm	to mm
GE..-AX	Steel/steel	12 240-3	10	200

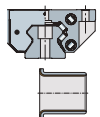

Product overview Maintenance-free rod ends

With internal thread

Unsealed or lip seals on both sides

GIR..-UK, GIR..-UK-2RS



GIL..-UK, GIL..-UK-2RS



GIKR..-PW, GIKPR..-PW

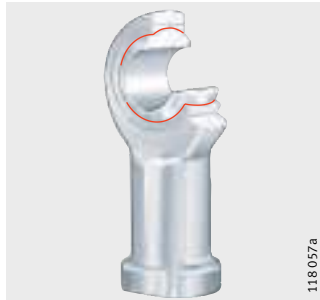

GIKL..-PW



With external thread

Unsealed or lip seals on both sides

GAR..-UK, GAR..-UK-2RS

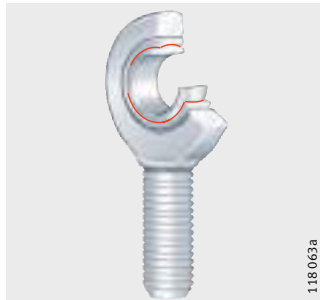

GAL..-UK, GAL..-UK-2RS

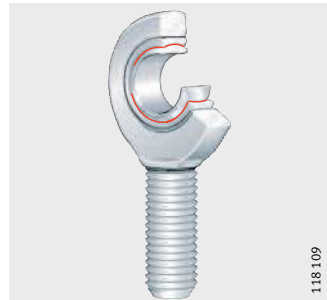

GAKR..-PW

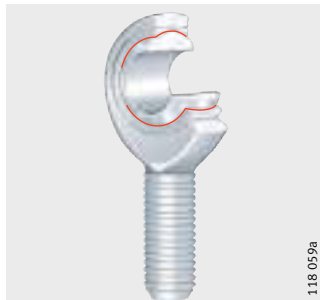

GAKL..-PW

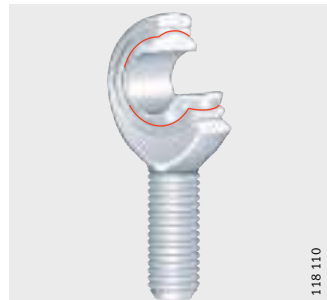

Maintenance-free rod ends

Features Maintenance-free rod ends comprise a housing with integral shank and a maintenance-free spherical plain bearing. The integral shank has an internal or external thread. The spherical plain bearing is firmly seated and located in the housing. The housings and shanks are protected against corrosion by zinc plating.

The rod ends can support radial loads in a tensile or compressive direction. They are suitable for slow movements with small to moderate swivel angles, for unilateral load and under certain conditions for alternating loads (suitable for alternating loads with GE..-UK-2RS).

Sealed rod ends have lip seals on both sides and are thus protected against contamination and water spray. This variant has the suffix 2RS.

Rod ends to DIN ISO 12 240-4, dimension series E have radial spherical plain bearings GE..-UK or GE..-UK-2RS with sliding contact surfaces comprising hard chromium/PTFE composite material or hard chromium/ELGOGLIDE® and a right or left hand internal or external thread. The thin-walled design of the eye housing allows compact adjacent constructions.

Rod ends to DIN ISO 12 240-4, dimension series K have radial spherical plain bearings GE..-PW with sliding contact surfaces comprising steel/PTFE-bronze film and a right or left hand internal or external thread.

Rod ends with internal thread

The table shows rod ends with an internal thread.

Series, thread type, standard

Series	Thread type	Standard to DIN ISO, type F	Shaft diameter	
			from mm	to mm
GIR..-UK	Right hand thread	12 240-4, dimension series E	6	30
GIL..-UK	Left hand thread	12 240-4, dimension series E	6	30
GIR..-UK-2RS	Right hand thread	12 240-4, dimension series E	35	80
GIL..-UK-2RS	Left hand thread	12 240-4, dimension series E	35	80
GIKR..-PW	Right hand thread	12 240-4, dimension series K	5	30
GIKL..-PW	Left hand thread	12 240-4, dimension series K	5	30
GIKPR..-PW	Right hand thread	12 240-4, dimension series K	5	30

Rod ends with external thread

The table shows rod ends with an external thread.

Series, thread type, standard

Series	Thread type	Standard to DIN ISO, type M	Shaft diameter	
			from mm	to mm
GAR..-UK	Right hand thread	12 240-4, dimension series E	6	30
GAL..-UK	Left hand thread	12 240-4, dimension series E	6	30
GAR..-UK-2RS	Right hand thread	12 240-4, dimension series E	35	80
GAL..-UK-2RS	Left hand thread	12 240-4, dimension series E	35	80
GAKR..-PW	Right hand thread	12 240-4, dimension series K	5	30
GAKL..-PW	Left hand thread	12 240-4, dimension series K	5	30

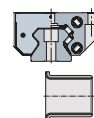

Product overview Rod ends requiring maintenance

With internal thread

Unsealed or
lip seals on both sides

GIR..-DO, GIR..-DO-2RS



GIL..-DO, GIL..-DO-2RS



GIKR..-PB



GIKL..-PB



With external thread

Unsealed or
lip seals on both sides

GAR..-DO, GAR..-DO-2RS



GAL..-DO, GAL..-DO-2RS



GAKR..-PB



GAKL..-PB



Rod ends requiring maintenance

Features These rod ends comprise a housing with integral shank and a spherical plain bearing requiring maintenance. The shank has an internal or external thread, the spherical plain bearing is firmly seated and located in the housing.

The rod ends can support radial forces in a tensile or compressive direction, transmit movements and forces at low moment levels and are suitable for alternating loads and, under certain conditions, unilateral loads.

Protection against corrosion is provided by zinc plating, the thin-walled design of the eye housing allows compact adjacent constructions.

Sealed rod ends are protected against contamination and water spray by lip seals. These bearings have the suffix 2RS.

Rod ends to DIN ISO 12 240-4, dimension series E have radial spherical plain bearings GE..-DO or GE..-DO-2RS with steel/steel sliding contact surfaces, a right or left hand internal or external thread and tapered lubrication nipples to DIN 71 412. They can be relubricated via the lubrication nipple or the housing bore.

Rod ends to DIN ISO 12 240-4, dimension series K have a right or left hand internal or external thread and funnel type lubrication nipple to DIN 3 405 on the rod end eye housing.

Rod ends with internal thread

Dimension series E, type F has a steel/steel sliding contact surface, while dimension series K, type F has a steel/bronze sliding contact surface.

Series, thread type, standard

Series	Thread type	Standard to DIN ISO, type F	Shaft diameter	
			from mm	to mm
GIR..-DO	Right hand thread	12 240-4, dimension series E	6	30
GIL..-DO	Left hand thread	12 240-4, dimension series E	6	30
GIR..-DO-2RS	Right hand thread	12 240-4, dimension series E	35	80
GIL..-DO-2RS	Left hand thread	12 240-4, dimension series E	35	80
GIKR..-PB	Right hand thread	12 240-4, dimension series K	5	30
GIKL..-PB	Left hand thread	12 240-4, dimension series K	5	30

Rod ends with external thread

Dimension series E, type M has a steel/steel sliding contact surface, while dimension series K, type M has a steel/bronze sliding contact surface.

Series, thread type, standard

Series	Thread type	Standard to DIN ISO, type M	Shaft diameter	
			from mm	to mm
GAR..-DO	Right hand thread	12 240-4, dimension series E	6	30
GAL..-DO	Left hand thread	12 240-4, dimension series E	6	30
GAR..-DO-2RS	Right hand thread	12 240-4, dimension series E	35	80
GAL..-DO-2RS	Left hand thread	12 240-4, dimension series E	35	80
GAKR..-PB	Right hand thread	12 240-4, dimension series K	5	30
GAKL..-PB	Left hand thread	12 240-4, dimension series K	5	30

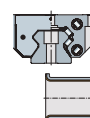

Product overview Hydraulic rod ends

Hydraulic rod ends

GIHNRK..-LO

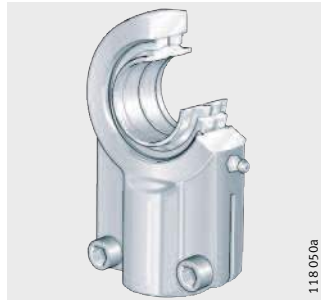

GIHRK..-DO



GK..-DO



GF..-DO

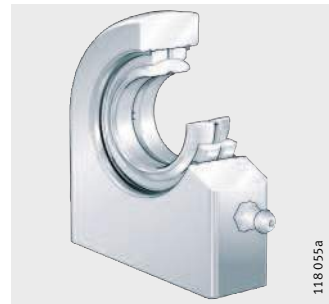

Hydraulic rod ends

Features Hydraulic rod ends are fitted with radial spherical plain bearings GE...LO or GE...DO. They have steel/steel sliding contact surfaces, can support radial forces in a tensile or compressive direction, transmit movements and forces at low moment levels and are suitable for alternating loads.

The shanks can be screw mounted using a thread in the shank or welded in place by means of circular or rectangular welding faces.

Rod ends with a circular welding face have a 45° weld chamfer and a centring facility by means of a concentric locating pin. They are particularly suitable for piston rods. Hydraulic rod ends with a rectangular cross-section are particularly suitable for cylinder bases.

The rod ends are slotted on both sides up to $d \leq 50$ mm, and on one side from $d > 50$ mm; they can be relubricated via tapered lubrication nipples.

Hydraulic rod ends with thread clamping

GIHNRK...LO is designed in accordance with DIN 24 338, ISO 6 982 for standard hydraulic cylinders to Cetop recommendation RP 58 H, DIN 24 333, DIN 24 336, ISO/DIS 6 020 I and ISO/DIS 6 022.

The spherical plain bearings are located in the housing by retaining rings. The thread clamping facility comprises two hexagonal socket head screws to DIN EN ISO 4 762.

GIHRK...DO is particularly suitable for hydraulic cylinders. It has very small linkage distances with maximum stroke utilisation. These rod ends are also available with maintenance-free spherical plain bearings GE...UK-2RS, GE...FW-2RS.

Series, thread type, standard

Series	Thread type	Standard to DIN ISO	Shaft diameter	
			from mm	to mm
GIHNRK...LO	Right hand thread	6 982	12	200
GIHRK...DO	Right hand thread	–	20	120
GIHLK...DO	Left hand thread	–	20	120

Hydraulic rod ends with welding face

GK...DO is designed in accordance with DIN ISO 12 240-4, dimension series E, type S with a circular welding face, a centring pin on the shank base and 45° welding chamfer. They are suitable for fixing to piston rod ends and cylinder bases.

The spherical plain bearings are located in the housing by staking on both sides.

GF...DO is available in a heavy-duty design with a rectangular welding face. The spherical plain bearings are located in the housing by retaining rings and can be dismantled. These rod ends are suitable for fixing to hydraulic cylinder bases.

Series, welding face, standard

Series	Welding face	Standard to DIN ISO	Shaft diameter	
			from mm	to mm
GK...DO	Circular	12 240-4, dimension series E, type S	10	80
GF...DO	Rectangular	–	20	120

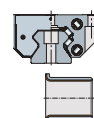

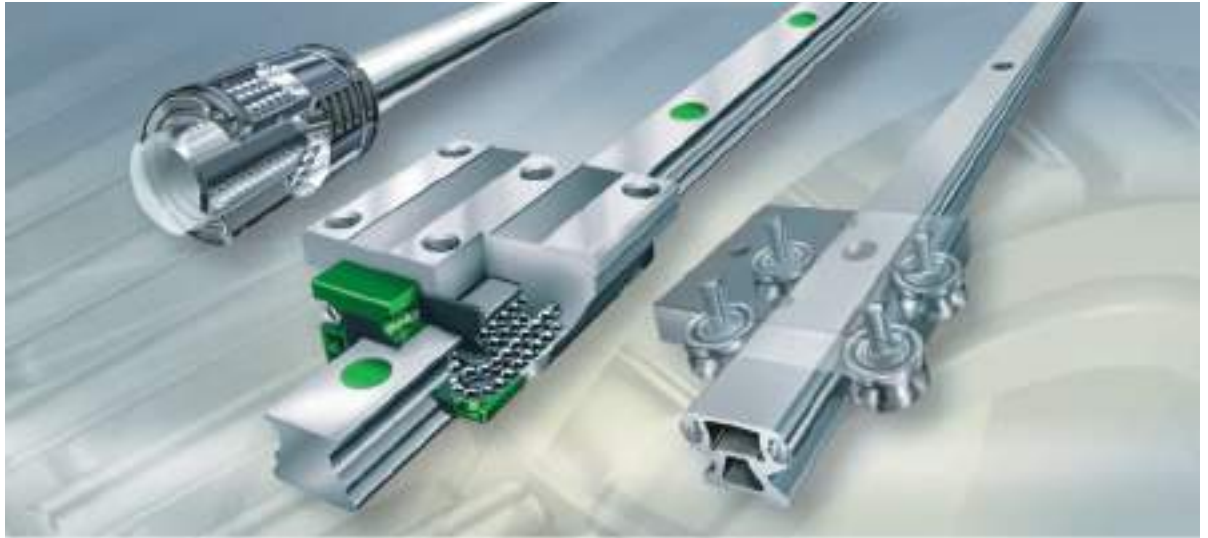

Linear guidance systems

Monorail guidance systems

Shaft and track roller guidance systems

Flat cage and recirculating roller guidance systems

Miniature guidance systems

Driven linear units

Linear guidance systems

		Page
Product overview	Monorail guidance systems	1400
Features	Linear recirculating roller bearing and guideway assemblies	1401
	Six-row linear recirculating ball bearing and guideway assemblies	1402
	Four-row linear recirculating ball bearing and guideway assemblies	1402
	Two-row linear recirculating ball bearing and guideway assemblies	1402
Product overview	Shaft and track roller guidance systems	1404
Features	Shaft guidance systems	1405
	Track roller guidance systems	1405
Product overview	Flat cage and recirculating roller guidance systems	1406
Features	Flat cage guidance systems	1407
	Linear recirculating roller guidance systems	1407
Product overview	Miniature guidance systems.....	1408
Features	Two-row miniature linear recirculating ball bearing and guideway assemblies	1409
	Four-row miniature linear recirculating ball bearing and guideway assemblies	1409
	Miniature carriage units.....	1409
	Miniature linear guidance sets	1409
Product overview	Driven linear units	1410
Features	Linear actuators	1411
	Linear tables	1411

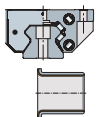

Product overview **Monorail guidance systems**

Linear recirculating roller bearing and guideway assemblies

RUE

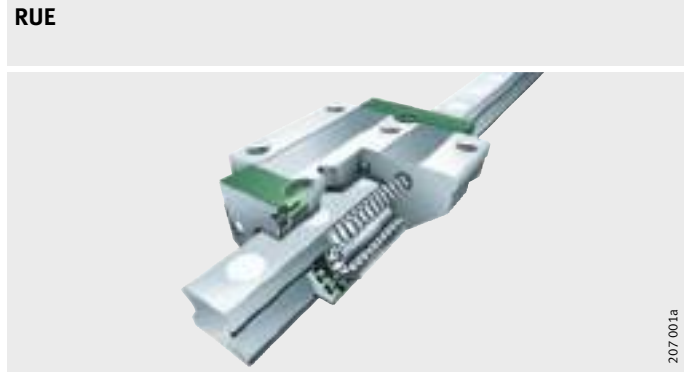

Six-row linear recirculating ball bearing and guideway assemblies

KUSE

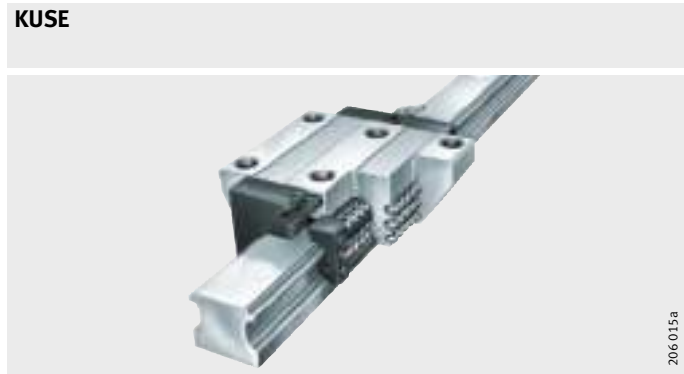

Four-row linear recirculating ball bearing and guideway assemblies

KUVE

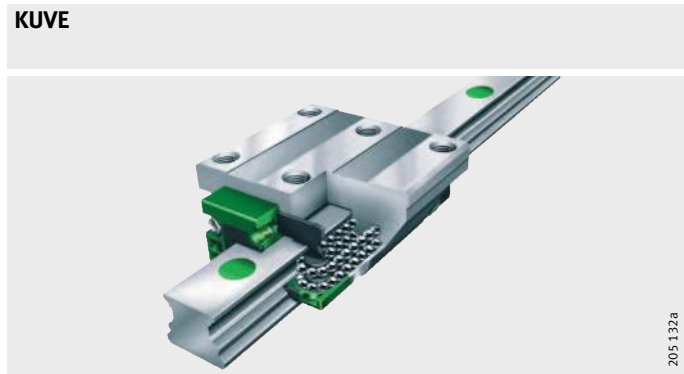

Two-row linear recirculating ball bearing and guideway assemblies

KUE

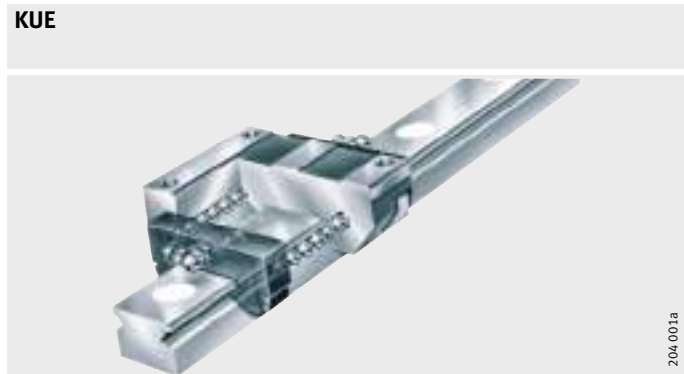

Monorail guidance systems

Features INA monorail guidance systems are compact linear guidance systems based on roller or balls with high rigidity and load carrying capacity. These guidance systems can support loads from all directions – apart from the direction of motion – and moments about all axes.

They are available in various accuracy and preload classes and are therefore suitable for applications with high guidance and positioning requirements.

Monorail guidance systems are based on a modular concept, i. e. guideways can be combined with all carriage types within each size. This gives more economical stockholding, simpler fitting and more rapid spare parts purchasing.

In order to reduce maintenance intervals and maintenance costs, monorail guidance systems have a lubricant reservoir. The carriages are sealed on all sides, protecting the rolling element systems against contamination even under critical operating conditions.

Catalogue: The complete standard range of monorail guidance systems is described comprehensively in Catalogue 605 and the CD and online versions of *medias*[®] *professional*.

Linear recirculating roller bearing and guideway assemblies Linear recirculating roller bearing and guideway assemblies RUE are, due to the cylindrical rollers, the INA monorail guidance systems with the highest load carrying capacity and rigidity. They comprise at least one carriage with a full complement roller system, a guideway, integral elastic wipers on the end faces of the carriage, sealing strips on the upper side and underside of the carriage and closing plugs to close off the fixing holes in the guideway.

The carriage and guideway of a linear recirculating roller bearing and guideway assembly are matched to each other due to their closely toleranced preload. It may be possible, after consultation, to use carriages and guideways in different combinations.

Linear recirculating roller bearing and guideway assemblies are suitable for accelerations up to 100 m/s^2 , speeds up to 180 m/min and operating temperatures from -10 °C to $+100 \text{ °C}$. They are used in applications with long unrestricted strokes, high and very high loads and high to very high rigidity.

The units are also available in a variant with optimised noise characteristics and in X-life quality.

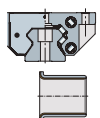

Monorail guidance systems

Six-row linear recirculating ball bearing and guideway assemblies

Six-row linear recirculating ball bearing and guideway assemblies KUSE are the guidance systems based on balls with the highest load carrying capacity and rigidity. They comprise at least one carriage with a full complement ball system, a guideway, integral elastic wipers on the end faces of the carriage, sealing strips on the underside of the carriage and plastic closing plugs.

Linear recirculating ball bearing and guideway assemblies KUSE are suitable for accelerations up to 150 m/s^2 , speeds up to 300 m/min and operating temperatures from $-10 \text{ }^\circ\text{C}$ to $+100 \text{ }^\circ\text{C}$. They are used in applications with long unrestricted strokes, high and very high loads and high to very high rigidity.

Four-row linear recirculating ball bearing and guideway assemblies

Four-row linear recirculating ball bearing and guideway assemblies KUVF are the most versatile and most extensively developed range of monorail guidance systems from INA. These units comprise at least one carriage with a full complement ball system, a guideway, integral elastic wipers on the end faces of the carriage, sealing strips on the upper side and underside of the carriage and plastic closing plugs.

Linear recirculating ball bearing and guideway assemblies KUVF are suitable for accelerations up to 150 m/s^2 , speeds up to 300 m/min and operating temperatures from $-10 \text{ }^\circ\text{C}$ to $+100 \text{ }^\circ\text{C}$. They are used in applications with long unrestricted strokes, high loads, high rigidity and low friction.

The units are also available in a variant with optimised noise characteristics and in X-life quality.

Two-row linear recirculating ball bearing and guideway assemblies

Two-row linear recirculating ball bearing and guideway assemblies KUE are the economical alternative where guidance systems with moderate load capacity are required. The units comprise at least one carriage with a full complement ball system, a guideway, integral elastic wipers on the end faces of the carriage, sealing strips on the underside of the carriage and plastic closing plugs.

Linear recirculating ball bearing and guideway assemblies KUE are suitable for accelerations up to 150 m/s^2 , speeds up to 180 m/min and operating temperatures from $-10 \text{ }^\circ\text{C}$ to $+100 \text{ }^\circ\text{C}$. They are used for long unrestricted strokes, moderate loads, moderate rigidity and low friction.

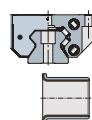

Product overview Shaft and track roller guidance systems

Shaft guidance systems

WF



Track roller guidance systems

LF

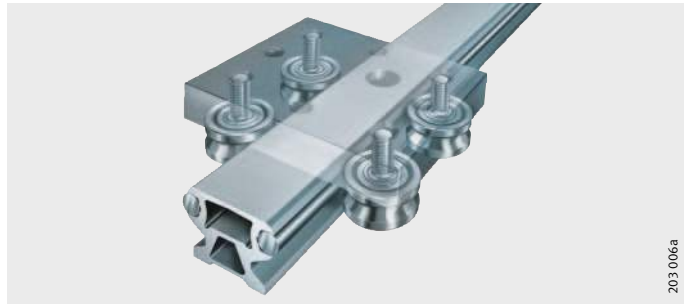

Shaft and track roller guidance systems

Features

Shaft guidance systems

INA shaft guidance systems are linear guidance systems based on ball bearings or plain bearings for various areas of use and applications. Linear ball bearings are available as a light range, compact range and heavy range. The mating tracks may be in the form of solid shafts, hollow shafts or supported shaft and support rail units.

The range is rounded out by a large selection of linear ball bearing and housing units and linear plain bearing units. In this case, the linear ball bearings or linear plain bearings are already mounted in ready-to-fit housings.

A large number of shafts (with and without machined features), shaft and support rail units and a versatile range of accessories allow a wide spectrum of applications.

Track roller guidance systems

INA track roller guidance systems are linear guidance systems that can be configured on a modular basis for an extremely wide variety of applications. Due to their lightweight construction, they are highly suitable for use in handling systems. They are characterised in particular by quiet running, high traverse speeds, long travel distances and the modular concept.

Track roller guidance systems comprise one or more carriages made from aluminium, profiled track rollers and a straight or curved guideway. The carriages are available as hollow section carriages, open carriages, compact carriages and bogie carriages for curved, oval and circular guidance systems.

The guideways are made from aluminium with rolled-in raceway shafts made from rolling bearing steel. The guideways are available in numerous different designs, e.g. solid profile guideway, hollow section guideway, flat guideway, guideway with slot etc. Their selection is based on the intended purpose of the track roller guidance system.

Catalogue: Shaft and track roller guidance systems

The standard range is described comprehensively in Catalogue 801 and the CD and online versions of *medias*[®] *professional*.

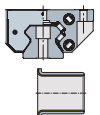

Product overview Flat cage and recirculating roller guidance systems

Flat cage guidance systems

M/V, ML/V, MVZ, J/S



209 001a

Linear recirculating roller guidance systems

RUS, RUS..-KS, PR, RUSW

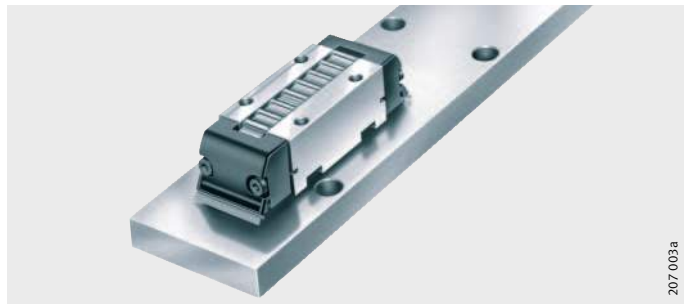

207 003a

Flat cage guidance systems and linear recirculating roller guidance systems

Features

Flat cage guidance systems

Where linear locating or non-locating bearings with extremely high load carrying capacity, very smooth running and low, uniform friction are required for limited stroke lengths, flat cage guidance systems are used. These guidance systems comprise a guideway arrangement separated by needle or cylindrical roller flat cages. The guidance systems have particularly high rigidity, high accuracy and low friction and require significantly less space than other linear guidance systems.

Linear recirculating roller guidance systems

Linear recirculating roller guidance systems comprise a bearing arrangement system for linear motion with unlimited stroke. Since the guidance elements have a versatile range of possible arrangements, linear recirculating roller guidance systems are suitable for numerous applications in general machine building, especially for linear guidance systems in machine tools where high guidance and positioning accuracies are required over long traverse distances.

The range of recirculating guidance systems is complemented by:

- INA adjusting gibs for precise setting of preload
- INA setting devices for measuring the deformation of the adjacent construction where preload forces must be supported
- INA adapters for easy fitting of linear recirculating roller bearings in 45° arrangements.

Catalogue: Flat cage and recirculating roller guidance systems

The standard range is described comprehensively in Publication FRF and the CD and online versions of *medias*[®] *professional*.

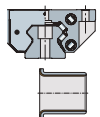

Product overview **Miniature guidance systems**

Two-row miniature linear recirculating ball bearing and guideway assemblies

KWEM, TKDM

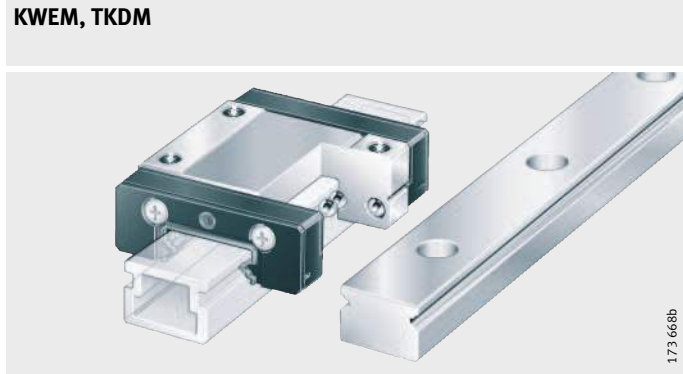

Four-row miniature linear recirculating ball bearing and guideway assemblies

KUME..-C

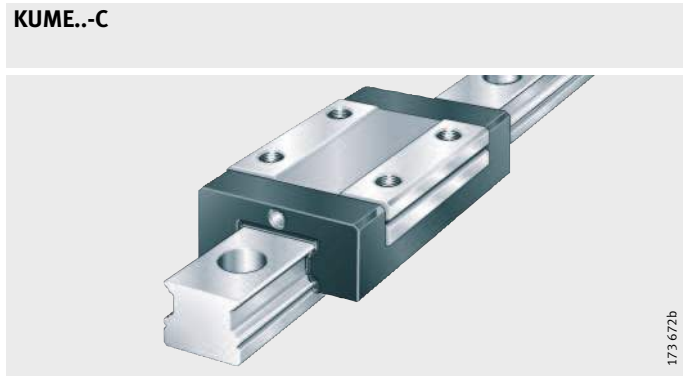

Miniature carriage units

RMWE..-VA

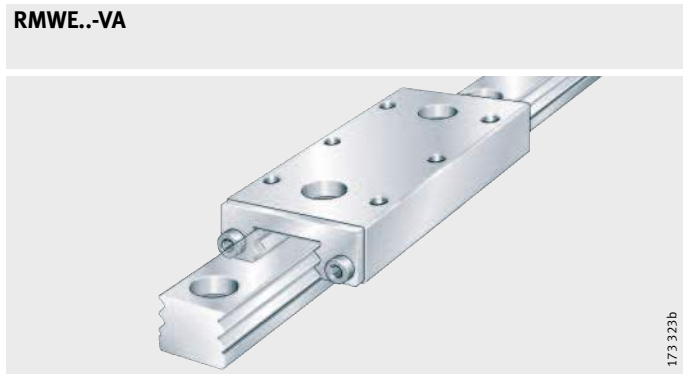

Miniature linear guidance sets

RWS



Miniature guidance systems

Features

INA miniature guidance systems are not standard linear guidance systems that have simply been reduced in size but were specially developed for very small design envelopes. Due to their compact design, they can often be used to replace bearing arrangements that require significantly more space. The guidance systems are preloaded linear locating bearings for limited and unlimited stroke lengths.

Two-row miniature linear recirculating ball bearing and guideway assemblies

These units have moderate load carrying capacity and moderate to high moment load carrying capacity. Due to their modular concept, guideways and carriages can be interchanged within each interchangeability and accuracy class. This simplifies the fitting of guidance systems, gives easier spare parts purchasing and allows very economical stockholding. The saddle plates and guideways are corrosion-resistant. Seals on the end faces of the carriages protect the rolling element system against contamination. The carriages are greased and can be relubricated. The guideways and carriages are also available in a wide version. Information on the units is given in Market Information MAI 81.

Four-row miniature linear recirculating ball bearing and guideway assemblies

Four-row miniature linear recirculating ball bearing and guideway assemblies are ready-to-fit guidance systems for unlimited stroke lengths. They have high to very high load carrying capacity and rigidity. Due to the lubricant reservoir, the relubrication intervals can be extended. The saddle plates and guideways are corrosion-resistant. Seals on the end faces of the carriages protect the rolling element system against contamination. The carriages are greased and can be relubricated. Information on the units is given in Market Information MAI 81.

Miniature carriage units

Miniature carriage units with cylindrical roller flat cages are corrosion-resistant, ready-to-fit cage guidance systems for limited stroke lengths. They have a high load carrying capacity, high rigidity and high accuracy whilst requiring very little space. Information on the units is given in Market Information MAI 77.

Miniature linear guidance sets

Miniature linear guidance sets with cylindrical roller flat cages are corrosion-resistant, ready-to-fit locating bearings for limited stroke lengths and are preloaded during fitting. These linear guidance systems have high load carrying capacity, high rigidity and high accuracy whilst requiring very little space. Since the layout of the guidance system can be varied, the elements can be easily matched to predetermined adjacent constructions. The sets are particularly suitable for short stroke lengths, low-friction and oscillating motion and high loads with very high rigidity. Information on the units is given in Market Information MAI 79.

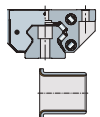

Product overview **Driven linear units**

Linear actuators with linear recirculating ball bearing and guideway assemblies and toothed belt drive

MKU..-ZR



Linear actuators with linear recirculating ball bearing and guideway assemblies and ball screw drive

MKU..-KGT

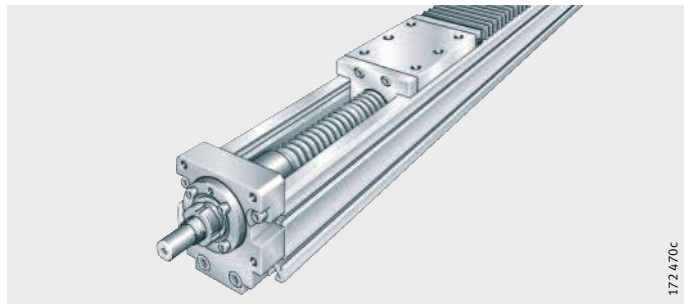

Linear actuators with linear recirculating ball bearing and guideway assemblies and direct drive

MKUVS42LM

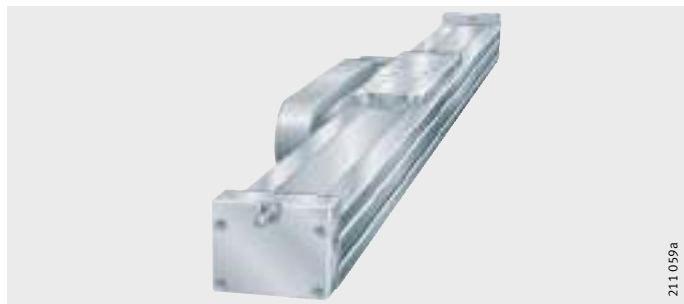

Linear tables with and without drive

LT

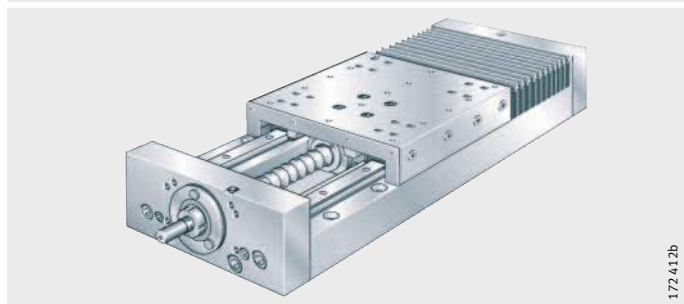

Driven linear units

Features	Rapid progress in the automation of production and assembly processes has pushed forward the development of complete, driven assemblies. These comprise a high precision guidance system, a rigid support rail, a wear-free drive unit and a user-friendly controller.
Linear actuators	INA linear actuators are integrated modular systems containing all the components required for operation. The linear actuators are guided by linear ball bearing and guideway assemblies of series KUE, KUVE or KUSE, by track roller guidance systems LF or plain guidance systems. The drive function is carried out by a ball screw drive, toothed belt or direct drive.
Linear tables	<p>INA linear tables are used where larger masses are moved in one or more axes. Due to the large distances between support points, linear tables are also capable of supporting high torques. The guidance systems used are linear ball bearings or linear ball bearing and guideway assemblies.</p> <p>Linear tables are available without a drive mechanism, with a ball screw drive, with a trapezoidal lead screw drive or a direct drive.</p> <p>The INA range of driven linear units is complemented by suitable controllers, motors and gearboxes that are matched to each other for optimum performance.</p>
Publication: Driven linear units	Comprehensive information on these units is given in Publication ALE, information on units with direct drive is given in Market Information MAI 105.

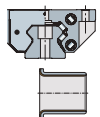

FAG



Equipment and services for the mounting and maintenance of rolling bearings

Equipment and services for the mounting and maintenance of rolling bearings

	Page
Equipment and services	
Industrial Services – Expertise in maintenance.....	1414
The FIS range.....	1414
Products for mounting and repair	1414
Products for lubrication	1416
Products for alignment	1416
Products for condition monitoring	1417
Products for maintenance management	1417
Mounting service.....	1418
Repair service for large rolling bearings	1418
Railway wheelset bearing maintenance	1418
Lubrication as a service	1419
Alignment service.....	1419
Condition Monitoring	1419
Maintenance management.....	1420
Training.....	1420

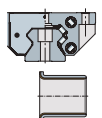

Equipment and services for the mounting and maintenance of rolling bearings

Equipment and services Industrial Services – Expertise in maintenance

Since the integration of FAG into the Schaeffler Group, F'IS has undertaken service tasks for the whole Group. F'IS is the specialist contact for the maintenance of rotating components. The aim is to help customers save on maintenance costs, optimise plant availability and avoid unforeseen machine downtime. The services are provided irrespective of the brand of the machine components used.

In order to provide a rapid, competent supply of F'IS products, services and training to customers worldwide, F'IS has specialist centres around the world. These work together with local partners that are certified and regularly audited by F'IS. Since each customer has a different set of requirements, F'IS offers concepts individually tailored to the customer.

The F'IS range

F'IS has implemented continuous expansion of its range over the years and offers products, services and training in the following five areas:

- Mounting/repair
- Lubrication
- Alignment
- Condition Monitoring
- Maintenance management.

For a detailed overview, see publication WL 80250.

Products for mounting and repair

Products for mechanical mounting and dismounting

For the mechanical mounting and dismounting of small and medium sized rolling bearings, F'IS offers mounting tool sets, various wrenches and mechanical extractors. Hydraulic extractors are used where higher extraction forces are required.

- Mounting tool sets
- Socket wrenches
- Hook and pin wrenches
- Mechanical extractors
- Hydraulic extractors, *Figure 1*
- Three-section extraction plates.

Products for hydraulic mounting and dismounting

In order to give easier mounting and dismounting of bearings with a tapered bore, hydraulic nuts are often used. Pressure generation devices available include oil injectors, hand pump sets and high pressure pumps. Selection is aided by the computer program MOUNTING MANAGER.

There is a comprehensive range of accessories, such as manometers, adapters and reduction nipples, high pressure hoses and sleeve connectors.

- Hydraulic nuts
- Oil injectors
- Hand pump sets
- High pressure pump
- Hydraulic systems and units
- Connectors, accessories.

Products for thermal mounting and dismounting

Rapid and energy-efficient heating of rolling bearings can be achieved with induction heating devices. FIS has table top equipment – including equipment for mobile use – and particularly effective standalone equipment.

- Electric heating plate
- Induction heating devices
- Heating rings, heat conducting paste
- Electric induction heating devices.



Figure 1
Dismounting of a bearing using a hydraulic extractor

Products for measurement and inspection

- Feeler gauges
- Taper gauges
- Snap gauge
- Enveloping circle gauges.

Accessories for mounting and dismounting

- Transport and mounting tools
- Gloves
- Mounting paste
- Anti-corrosion oil.

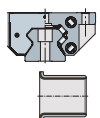

Equipment and services for the mounting and maintenance of rolling bearings

Products for lubrication

Lubricants

- Arcanol rolling bearing greases, *Figure 2*.

Lubrication systems

- Motion Guard SELECT Manager (software for selection of greases and lubrication systems)
- Motion Guard COMPACT
- Motion Guard CHAMPION
- Motion Guard CONCEPT6
- Dosing devices
- Grease gun.



Figure 2

Lubricants and lubrication systems

Products for alignment

Belt and chain drives

- Belt pulley alignment device Top-Laser SMARTY
- Belt tension measuring device Top-Laser TRUMMY.

Shaft couplings and alignment accessories

- Shaft alignment device Top-Laser INLINE, *Figure 3*
- Shims Top-Laser SHIMS.



Figure 3

Shaft alignment device
Top-Laser INLINE

**Products for
condition monitoring**
Operating condition monitoring

- Temperature measuring devices
- Digital hand tachometer
- Sonar device.

Vibration diagnosis

- Detector
- Bearing Analyser, *Figure 4*
- EasyCheck
- EasyCheck Online
- DTECT X1
- WiPro
- Screen Saver
- VibroCheck.



Figure 4
Condition monitoring

**Products for
maintenance management**

- CMMS* Interface.

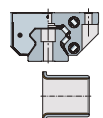

Equipment and services for the mounting and maintenance of rolling bearings

Mounting service

The F'IS Mounting Team offers mounting services for rolling bearings across market sectors, *Figure 5*. We have extensive experience, for example in railways, mining, steel and aluminium, wind power, paper etc.



Figure 5
Mounting of a large rolling bearing

Repair service for large rolling bearings

During the maintenance of machinery and plant, many rolling bearings are taken out of service and replaced by new ones as a precaution. This exaggerated safety-consciousness blocks any appreciation of the potential cost savings.

The fact is: reconditioned bearings generally give the same performance as new ones. The F'IS experts repair all types of rolling bearings such as cylindrical roller bearings, spherical roller bearings, tapered roller bearings etc.

Railway wheelset bearing maintenance

Wheelset bearings for railway vehicles are among the most heavily loaded vehicle parts. Their life can be increased significantly by appropriate and regular maintenance. F'IS therefore offers operators of all railway vehicles the opportunity to have their wheelset bearings professionally dismantled, cleaned and reconditioned.

Lubrication as a service

In more than half of all cases, inadequate lubrication is the cause of unplanned machine downtime. The use of suitable greases makes it possible to significantly extend the life of rotating machine parts. FIS services include the selection and installation of lubricants and lubrication systems, the lubrication of bearing positions, the preparation of lubrication and maintenance plans, lubrication point management, lubrication consultancy and lubricant investigations and tests.

Alignment service

Incorrect alignment of belts and shafts are among the most common causes of unplanned machine downtime.

In addition to detailed analysis of causes, the FIS service includes alignment of belts and shafts on pumps, ventilators, compressors, electrical machinery etc. as well as the detection and correction of positional deviations in belts and shafts using FIS vibration and laser measurement devices.

Condition Monitoring

The malfunction-free and optimised operation of complex machinery and plant can only be achieved by means of condition-based maintenance. The key method used by FIS in condition-based maintenance is vibration diagnosis, *Figure 6*. This method makes it possible to detect incipient damage in machinery at a very early stage.

Above all, vibration diagnosis helps to avoid unplanned downtime and expensive secondary damage, increase productivity and improve plant availability.



Figure 6
Condition monitoring as a service

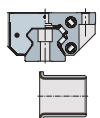

Equipment and services for the mounting and maintenance of rolling bearings

Maintenance management

Maintenance consultancy

Maintenance consultancy by F'IS helps to achieve better cost transparency and more effective design of maintenance arrangements, *Figure 7*. The F'IS team moves beyond classical consultancy and places the emphasis on technical perspectives.

IPS systems

In the field of maintenance planning and control systems (IPS systems), F'IS experts apply their sound technical knowledge to offer analysis of customer-specific requirements independent of the manufacturer. On this basis, the F'IS team achieves an IPS system optimised and tailor-made for the customer. The F'IS service covers both complete solutions in the form of IPS implementation as well as individual modules.



Figure 7

Maintenance consultancy

Training

F'IS offers, in relation to the product and service range, both standard training and customer-specific training, *Figure 8*. The individual training units are based on a modular concept with the result that customers can compile their own customised training course on the basis of these training components.

The training courses are offered both at Schaeffler Group locations and also on site at our customers. The current training offer including dates for the standard training courses can be found at www.fis-services.de in the section Training.



Figure 8

Training

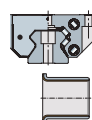



FAG



Market sectors

Production Machinery
Power Transmission and Railway
Heavy Industry
Consumer Products

Market sectors

	Page
Production Machinery	
Bearings for machine tools	1424
Bearings for printing machinery	1425
Bearings for textile machinery	1426
Bearings for the food industry	1427
Bearings for woodworking machinery	1427
Power Transmission and Railway	
Bearings for rail vehicles	1428
Bearings for power transmission	1429
Bearing arrangements in construction machinery	1430
Bearing arrangements in industrial conveying trucks	1430
Bearing arrangements in wind turbines	1431
Heavy Industry	
Bearing arrangements for the steel industry	1432
Bearing arrangements for the paper industry	1435
Bearing arrangements in deep and surface mining	1438
Bearings for materials processing	1440
Bearing arrangements in the air handling sector	1442
Consumer Products	1443



Market sectors

Schaeffler Group Industrial develops, manufactures and supplies ball bearings, roller bearings, bearing units, housings and accessories worldwide for almost all machinery, plant, vehicles and equipment. We also provide a comprehensive range of services for advice, maintenance and fitting.

Our customers are found in the Business Units Production Machinery, Power Transmission and Railway, Heavy Industry and Consumer Products.

Production Machinery

High performance production machinery is a precondition and a driving force of technical progress.

High precision bearings set standards both in their main application sector in machine tools and also in equipment for the textile industry, in printing machinery, woodworking machinery and machines for the food industry. They fulfil very high requirements for reliability, high running accuracy and/or high speeds.

Comprehensive information is given in Publication AC 41130, Super Precision Bearings.

Bearings for machine tools

Hybrid spindle bearings with steel rings and ceramic balls are finding increasing usage due to their particular speed capacity, robust characteristics and reliability as well as their significantly longer operating life. For very high requirements in terms of load carrying capacity and speed capacity, special X-life ultra bearings with rings made from high performance steel and ceramic balls have been developed.

Single and double row cylindrical roller bearings of high precision design are ideal for use as non-locating bearings, since they allow length compensation without constraining forces between the rollers and raceways. They give bearing arrangements with high radial rigidity, high load carrying capacity and high accuracy.

Double direction axial angular contact ball bearings of series 2344 are used as particularly rigid axial bearings when cylindrical roller bearings of series NN30 support the radial forces.

Bearings for printing machinery

Printing machinery bearings are used in the bearing arrangements of the main cylinders in sheetfed and webfed printing machines, *Figure 1*. Due to their load carrying capacity, rigidity, accuracy and precise adjustability, they provide excellent support for the central requirement in printing machinery, namely the highest possible print quality.

The bearings are specially designed in close partnership between printing machinery manufacturers and our Application Engineering functions. As a result, the bearings are precisely matched to the requirements of the customer. This matching of design to the specific machine concept is particularly important, since exceeding requirements is a drain on resources and failing to meet requirements impairs performance. Finding the optimum solution, however, is not always easy. Due to its considerable experience in the development, design and manufacture of bearings, Schaeffler Group Industrial has the know-how necessary to always offer the best solution for an application in this complex bearing sector. Furthermore, it is able to do so in both technical and economic terms.

Due to the wide range of requirements, standardisation of printing machinery bearings is only possible to a limited extent. The range therefore comprises a large number of types and sizes.

In addition to the classic multi-row, high precision cylindrical roller bearings NN, NNU, N4N, N4U, use is also made of non-locating bearing units without and with eccentric geometries, locating bearing units, polygon bearings, combined linear and rotary bearing units and tapered roller bearing units. Bearings are available with and without seals. The bearing seat for the cylinder journal can be of a cylindrical or tapered design.

INA printing machinery bearings are cost-effective bearing arrangement systems that can be used to achieve the demands of the print industry for high productivity, low maintenance costs and excellent print quality.



Figure 1
Printing machine bearing unit with eccentric outer ring – non-locating bearing

Special publications

Publication LFD High precision bearings for printing machinery.



Market sectors

Bearings for textile machinery

Whether it is spinning or weaving, finishing or processing, modern textile machines are highly automated and must run with high material throughput and without malfunctions – around the clock. There is no question that the right bearing components play a crucial role here. “Right” in this context means low friction, high accuracy, clearance-free, easy to fit, low maintenance, long service life, low noise and reliable.

In order to fulfil these requirements, Schaeffler Group Industrial has a comprehensive range of precision products for the reliable and cost-effective support of rotary and linear motion in textile machinery. We also have a range of system components that are precisely matched as complete systems to the specific application. Behind every one of these solutions lies years of experience in product development and the design of bearing arrangements.

Tape tension pulleys for gripper drives in weaving machines are renowned for their long life, *Figure 2*. These pulleys can be easily lubricated and have a very low moment of inertia. As a result, they run up to operating speed very quickly. In addition, the pulleys carry out up to 600 alternating rotary movements per minute in continuous operation with very low energy consumption. This gives a considerable increase in the productivity and cost-efficiency of the machine while achieving a uniformly high fabric quality.



Figure 2
Energy-saving tape tension pulley
for the gripper drive

We also have ready-to-fit tension pulleys with reduced running noise, *Figure 3*. Due to design measures, for example, the imbalance of these components has been reduced by 50%. As a result, it is no longer necessary to balance the pulleys separately.



Figure 3
Tape tension pulley with optimised noise characteristics for twisting machines

Such ready-to-fit units are used in single and multi-head embroidery machines and are simply screw mounted on the adjacent construction. This eliminates the matching of individual components to each other and reduces mounting errors. This solution also gives a simplified adjacent construction since it completely replaces the gearbox previously required.

The system comprises a lever, eccentric, connecting rod and the corresponding bearing units. The assembly converts the rotary motion of the drive shaft into the stroke motion for the embroidery operation. Due to the smooth-running, high accuracy running of the bearings, the unit can achieve more than 1000 strokes per minute. Highly effective seals ensure long life and low maintenance requirements.

Special publications

Publication TMB Rolling bearings for textile machinery.

Bearings for the food industry

In plansifters that are used to separate different materials in the mill plant, large centrifugal forces must be supported in the eccentric shaft of the sifter frame. Spherical roller bearings of the special design T41A for oscillating load are particularly suitable for this task.

Bearings for woodworking machinery

In many cases, deep groove ball bearings are adequate for the high speeds and relatively low loads in bearing arrangements for wood shapers. Very high speeds, however, normally require the use of spindle bearings.



Market sectors

Power Transmission and Railway

People and goods are being moved with increasing speed and over increasing distances from one place to another. Motors and transmissions must operate with increasing efficiency. In power transmission, construction machinery and railway engineering, therefore, high demands are being placed on the quality and life of rolling bearings.

Bearings for rail vehicles

In mainline and local trains, the dominant requirements are for higher speeds and smoother running. Bearings and housings for wheelsets, transmissions and motors are selected by the Application Engineering specialists so that they are ideally matched to the customer requirements, *Figure 4*.

Wheelset bearings are subjected to extreme loads and must fulfil very high safety requirements.

For wheelsets, cylindrical roller bearings with smooth running, low friction and high speed suitability are frequently used in specially developed wheelset bearing housings.

Wheelset bearings with spherical roller bearings are available for rigid housings connected to the vehicle or bogie.

Tapered roller bearing units TAROL are suitable for high running speeds and high axial loads. The ready-to-fit units can be mounted in a single operation, are sealed, lubricated and have a specially adjusted axial internal clearance. They are supplied in metric sizes (UIC range) or to the AAR specification in inch sizes.

Increasingly, wheelset bearing units with integrated sensors (for speed, temperature, direction of rotation etc.) are being used.



Figure 4
Tapered roller bearing unit
for passenger train carriages

In hydrodynamic and mechanical railway transmissions with oil lubrication, radial bearings of practically all types are used to guide the pinion shafts, intermediate shafts and ring gear shafts.

In the axle suspension drive, cylindrical roller bearings, tapered roller bearings or spherical roller bearings are used.

For large gear bearing arrangements (gear hub), tapered roller bearings in an O arrangement matched by means of intermediate rings are predominantly used.

In the bearing positions of the traction motors, cylindrical roller bearings and deep groove ball bearings have proved successful.

For rail vehicles, there are also support and guide rollers, bearings in ancillary equipment, wheelset bearings with adapters, electrically insulated deep groove ball bearings and cylindrical roller bearings to ISO dimensions, special Arcanol rolling bearing greases and mounting tools.

Special publications

WL 07170 Rolling bearings for rail vehicles, a complete range.

Bearings for power transmission

Modern gearboxes transmit high power levels within a small space. This requires careful selection of rolling bearings with high performance capacity. In addition to load carrying capacity, appropriate design of the adjacent parts, lubrication and sealing is a precondition for reliable and cost-effective bearing arrangements. In order to take account of these influences, it is particularly advantageous to use the expanded life calculation method.

Depending on the gearbox design and tooth set type, almost all types of rolling bearings are used in power transmission.

The input shafts of cylindrical gear units are often supported by spherical roller bearings or tapered roller bearings, *Figure 5*. For particularly high speeds, combinations of cylindrical roller bearings supporting radial loads and four point contact bearings under axial load are suitable. For intermediate and output shafts, spherical roller bearings in a floating arrangement are often selected.



Figure 5
Rolling bearings
in a cylindrical gear unit



Market sectors

In bevel gear pairs, a narrow axial guidance is often required in order to ensure tooth mesh. A solution here is to use axially adjusted or matched tapered roller bearings or angular contact ball bearings.

The high axial forces in the worm shaft of worm gear units can be transmitted using matched or adjusted tapered roller bearings. For worm gear shafts, adjustability and narrow axial guidance of the tooth set are required. Deep groove ball bearings or adjusted tapered roller bearings are often used.

In order to support planet gears in planetary gearboxes, single or multiple row cylindrical roller bearings are used, with spherical roller bearings being fitted in special cases. Thicker planet gear studs can be achieved with direct bearing arrangements. The rolling elements then run directly on the planet gear stud. The hardness curve and surface quality of the raceway must be produced to particular specifications in order to ensure the load carrying capacity and operating life of the planet gear bearing arrangement.

Bearing arrangements in construction machinery

Among the wide range of rolling bearing arrangements in construction machinery, the excitation shaft bearing arrangement in vibratory equipment deserves particular mention.

Road rollers, plate compactors, vibratory motors, vibratory piledrivers or vibrator frames work with mechanical vibrations. The exciter shafts and their eccentrically mounted weights run at high speeds. Deep groove ball bearings (for small vibratory equipment), spherical roller bearings and cylindrical roller bearings (N, NU design) have proved successful here.

In order to compensate for misalignments and shaft deflections, the rollers and inner ring raceways of the cylindrical roller bearings have a logarithmic transverse profile. This allows tilting of up to 4 angular minutes without impairing the life. For greater tilting, the transverse profile can be adapted.

Bearing arrangements in industrial conveying trucks

Examples of special bearing designs can be found in fork lift trucks. Sensor bearings combine proven rolling bearing technology and modern sensor technology for drive, control and monitoring. This ready-to-fit system solution offers numerous cost and performance advantages.

Bearing arrangements in wind turbines

Wind turbines can now generate power levels of more than 3 MW. The bearings must be able to support moderate to high loads, oscillation and vibration. Low friction standard rolling bearings are normally suitable here. The bearings are mounted in standard or special housings. For particular cases, special rolling bearings can also be used.

Rolling bearings for wind turbines are often subject to high quality requirements with corresponding documentary evidence (German Lloyd certification guidelines).

The rotor bearing arrangement can be in the form of a shaft or hub bearing arrangement, *Figure 6*. Locating/non-locating bearing arrangements with spherical, cylindrical or tapered roller bearings have proved successful.

In the hub bearing arrangement, two tapered roller bearings are adjusted against each other. An alternative solution comprises a matched pair of tapered roller bearings as a locating bearing and a cylindrical roller bearing as a non-locating bearing.

For single bearing designs, support of forces and moments is combined in a multiple-row rolling bearing.



Figure 6
Self-aligning
FAG spherical roller bearing
for rotor bearing arrangement

Small swivel movements in the adjustment of the rotor blade as well as high loads and tilting moments are normally supported by four point contact bearings.

As tower bearings, four point contact bearings support the high weights and wind forces.

In wind turbine gearboxes, all types of rolling bearings normally found in gearbox construction are used.

Special publications

WL 01206 Expertise in bearing technology and service for wind energy installations.



Market sectors

Heavy Industry

The difficult operating and environmental conditions in all areas of heavy industry require rolling bearings that are proven even in critical applications. This applies to mining, crude oil and natural gas gathering, materials processing, the steel industry, the paper industry and conveying equipment.

Bearing arrangements for the steel industry

The bearing arrangements in steelworks and rolling mills are generally subjected to very high loads and in many cases also to high temperatures and heavy contamination. In addition to standard rolling bearings, bearings specially for these conditions are required.

The rolling bearings for converters must support not only heavy weights but also severe shocks. Large spherical roller bearings of split or unsplit design fulfil these requirements.

The swivel arms of the turret in continuous casting plants are supported in large rolling bearings. Axial spherical roller bearings are often used to support the weights involved, with cylindrical roller bearings to support the tilting moment.

At the inner support point of driven guide rollers, split roller bearings are used. In order to protect the bearings from the high slab temperatures as well as scale and coolant water, the housings are cooled using water. The seals comprise lamellar sealing rings and labyrinth seals.

For the support of non-driven guide rollers and the outer support of driven guide rollers, unsplit bearings are used.

Sealed spherical roller bearings reduce the consumption of lubricant and thus the environmental impact, *Figure 7*.



Figure 7

Sealed spherical roller bearing for strand guide rollers

213 057

In order to support the high radial forces in rolling mills, cylindrical roller bearings with two or four rows are often selected, together with axial bearings in the form of deep groove ball bearings, angular contact ball bearings, double row tapered roller bearings, axial tapered roller bearings or axial spherical roller bearings. If tapered roller bearings with two or four rows are used as radial bearings, an additional axial bearing is not normally necessary.

Spherical roller bearings are common as roll bearings where high axial guidance accuracy is not required and speeds are low.

Sealed multi-row tapered roller bearings for work rolls reduce the consumption of lubricant and thus the environmental impact, *Figure 8*.

Axial tapered roller bearings for pressure spindles ensure low adjustment forces due to their low friction.



Figure 8
Sealed four row tapered
roller bearing for work rolls



Market sectors

Single row cylindrical roller bearings as well as single and double row angular contact ball bearings are found predominantly in high speed rolling mills for wire and fine iron production lines.

The drive shafts in heavy duty rolling mills have a considerable mass. They were previously normally supported in plain bearings. Now, wear and lubricant requirements are considerably reduced due to the use of special cylindrical roller bearings of split design.

Spherical roller bearings are frequently used in gearboxes for rolling mills. In newer designs, the shafts are supported in double row cylindrical roller bearings as non-locating bearings and in double row tapered roller bearings as locating bearings. This bearing arrangement gives particularly accurate radial and axial guidance of the shafts.

Split cylindrical roller bearings are frequently used in the crankshafts of cold pilger machines.

For the bearing arrangement of work rolls in cold pilger machines, spherical roller bearings with a tapered bore and a special internal construction are used that are matched to the particular load conditions in these machines.

The roll bearing arrangement of cluster type cold rolling mills must ensure high surface quality and uniform thickness of the rolled strips. Multi-row cylindrical roller bearings or tapered roller bearings fulfil these requirements as back-up rollers.

Special publications	WL 17104	Rolling bearing arrangements for converters
	WL 17114	Sealed FAG spherical roller bearings
	WL 17115	Bearings and Service – Productivity and Reliability for Metal Production
	WL 17200	FAG rolling bearings in rolling mills
	WL 41140	FAG rolling bearings for rolling mills.

Bearing arrangements for the paper industry

Modern large paper machines contain a large number of rolling bearings of various types and sizes. Very high operational reliability is demanded of all bearings in order to prevent expensive downtime. In many cases, monitoring is carried out using the FAG Diagnostic Service, *Figure 9*.

Attention must also be paid to ensuring ease of mounting. There are also special requirements depending on the type of paper machinery and the subassembly therein. In the wet end section, the emphasis is on preventing corrosion, while the bearings in the dry section must also be designed for high temperatures.

For suction box rolls in the wet end section, spherical roller bearings with a conical or cylindrical bore and increased running accuracy are normally used.

Spherical roller bearings with lubrication holes in the inner ring are used if the outer ring rotates.

For very high speeds, spherical roller bearings with increased running accuracy and increased internal clearance are installed.

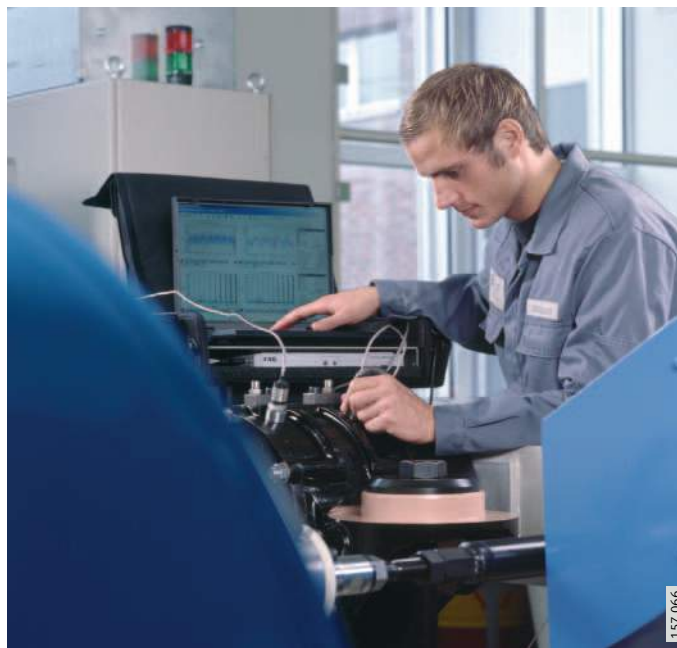

Figure 9
Condition-based
rolling bearing monitoring
using Bearing Analyser



Market sectors

An angular adjustment facility and high load carrying capacity are required in central press rolls, so spherical roller bearings are used, *Figure 10*. Sophisticated labyrinth seals are required in the wet section in order to avoid ingress of water spray.

In anti-deflection rolls, the roll sleeve rotates about the stationary roll axis. The roll sleeve is guided by spherical roller bearings, which may have special features including increased running accuracy, increased internal clearance and lubrication holes in the inner ring.

For driven rolls, three-ring bearings are sometimes used. The axis is supported in the bearing inner ring. The rotating intermediate ring connects the drive to the roll sleeve.



Figure 10
Spherical roller bearings E1
of X-life quality.
With superior
load carrying capacity,
reduced operating temperature
and very long operating life

The operating conditions in the dry section are characterised by high temperature and thermal expansion of the dryer roll. Spherical roller bearings are normally used as locating bearings. Up to a working width of approx. 5 m, spherical roller bearings are also used as non-locating bearings; these can be displaced axially in the housing in response to changes in the length of the dryer roll. For larger working widths, preference is given to double row cylindrical roller bearings with angular adjustment facility in normal plummer block housings, *Figure 11*. The spherical roller bearings have an increased internal clearance to C4, the cylindrical roller bearings have a radial internal clearance to C5.

For guide rollers in the dry section too, significant changes in length due to high ambient temperatures must be taken into consideration. The normal spherical roller bearings have an increased radial internal clearance. The bearings are connected to the oil loop of the dryer rolls. In large, high speed machines, the bearing inner rings with a conical bore are mounted directly on the tapered roll journals.

Calender thermo rolls in the end section are normally fitted with spherical roller bearings. Due to the high temperature, they have increased internal clearance and in some cases a conical bore. Heat is dissipated by means of high oil flow quantities.

In spreader rolls running at high speeds, the use of hybrid deep groove ball bearings with steel rings and ceramic balls has proved effective. Since this bearing has only half the usual number of balls, the risk of slippage is reduced.



Figure 11
Self-aligning
double row cylindrical roller bearing

Special publications

- WL 13103 Rolling bearing arrangements for the paper industry
- WL 13111 FAG cylindrical roller bearings with angular adjustment facility for dryer/smoothing rolls and guide rolls in paper machinery
- WL 13115 Optimum paper production/ bearing technology with complete service.



Market sectors

Bearing arrangements in deep and surface mining

The machines used in deep and surface mining perform extremely arduous work.

The high load carrying capacity of the drill head bearing arrangement in tunnel-driving machines is ensured by cylindrical roller bearings and spherical roller bearings. The mass and tilting forces resulting from the offset drilling pressure are supported by single or double row radial cylindrical roller bearings or spherical roller bearings. The drilling pressure is supported by axial roller bearings.

In larger, compact machines, the drill head bearing arrangement is a ready-to-fit unit. It comprises either a double row tapered roller bearing or a three-ring axial/radial cylindrical roller bearing in which the crown gear can be integrated, *Figure 12*. The bearing unit can withstand all load combinations of axial force, radial force and tilting moment.



Figure 12
Axial/radial
cylindrical roller bearing
with integrated crown gear

The forces acting on the drive pinions of tunnel-driving machines are securely supported by one spherical roller bearing and one cylindrical roller bearing.

In conveying and lifting equipment, the main requirement is for standardised rolling bearings of all types, sizes and variants. Some applications require large or split bearings.

The bucket wheel in bucket wheel excavators is supported by large spherical roller bearings (unsplit in the original equipment version, split in the replacement bearing version), *Figure 13*. These bearings support high loads and compensate, without constraining forces, the substantial misalignments that result from the large spacing between the locating and non-locating bearings.

Other demands placed on the bearing arrangement include:

- handling large fluctuations in operating temperature
- long life
- sealing against slurry, moisture, contamination and sand
- simple maintenance as well as low time and cost outlay in mounting and dismantling.



Figure 13
Split spherical roller bearing

For gearbox bearing arrangements and for the bearing arrangement between the main gear and the hollow shaft flange, split cylindrical roller bearings are best suited due to the difficulty of access for bearing replacement.

One of many different drums in a belt installation is the drive drum. Spherical roller bearings allow compensation without constraining forces of the misalignments resulting from shaft deflections and deformation of the channels; these can fulfil the requirement for high operational reliability with low maintenance outlay. Specially developed housings are available for all bearing sizes.

The support rollers, connected either rigidly or in a jointed arrangement with each other, are normally fitted with deep groove ball bearings that are standardised, sealed and lubricated for life. Externally mounted seals prevent contamination entering the bearing arrangement.

Special publications

- WL 21107 Heavy-Duty Rolling and Plain Bearings for Mining, Processing, On- and Offshore Technology
- WL 43165 Split FAG spherical roller bearings
- WL 90118 Split FAG plummer block housings of series SNV.



Market sectors

Bearings for materials processing

Extreme operating and environmental conditions require robust bearing arrangements in crushers and mills, sieving and sorting machines as well as cylindrical rotary kilns, pelletising and sintering plants. Substantial shaft deflections and misalignments of the bearing positions must be compensated. High demands are made on the lubrication and sealing of the bearings.

Due to the high forces and harsh operation in crushers, spherical and cylindrical roller bearings are normally used.

In jaw crushers – also known as crosshead or double toggle crushers – spherical roller bearings support the crushing forces, the mass of the flywheels and the peripheral force of the drive via an eccentric shaft.

In gyratory or cone type crushers, the high radial forces are transmitted by two cylindrical roller bearings (outer bearings) and a spherical roller bearing (central bearing). The axial weight is normally supported by an axial cylindrical roller bearing. Crusher cone and crusher shaft bearing arrangements with single and double row radial and axial cylindrical roller bearings or with large special tapered roller bearings are also in use.



Figure 14
Large spherical roller bearings
for tube mills

For the rotating striking trains of single and twin shaft hammer crushers, spherical roller bearings are suitable due to the harsh operation and shaft deflection.

Heavy weights and shock type loads are characteristic of tube mills and also of hammer mills, impact crushers, rigid hammer crushers and impact wheel mills. Spherical roller bearings in specially developed housings are suitable for these requirements, *Figure 14*. In roller grinding mills, the pressing, tilting and axial forces acting on the mill roller induce high radial and axial loads. These can be supported by a cylindrical roller bearing in combination with a spherical roller bearing or a tapered roller bearing unit in an X arrangement. In other roller grinding mills, each mill roller is supported by two tapered roller bearings mounted in an O arrangement.

Preferred bearing types for roller presses are spherical roller bearings and multi-row cylindrical roller bearings.

In order to support the particularly high shock type loads and radial accelerations of the exciter shaft in linear and free vibrators as well as eccentric screens, spherical roller bearings of series 223..-E1 and 223..-A of special designs are used, *Figure 15*. These bearings are characterised by cages guided on the outer ring, restricted tolerances and increased radial internal clearance. For special cases, spherical roller bearings of series 223..-E1A and 233..-A are also used.



Figure 15
Spherical roller bearings
for oscillating stresses

The high combined loads at low speeds are supported in the radial track rollers of cylindrical rotary kilns by spherical roller bearings of series 241; they are located in split RLE or RLZ plummer block housings. In axial track rollers, tapered roller bearings in an O arrangement have proven successful.

For the bearing arrangement of the pinion drive shaft, spherical roller bearings in specially developed RA plummer block housings have proven successful.

The particular operating conditions in sintering and pelletising plant are best met by spherical roller bearings with a tapered bore on extraction sleeves. The bearings are mounted in split RA or SGB plummer block housings. Sealed double row cylindrical roller bearings can be considered for the bearing arrangements of pressure rollers, tapered roller bearings can be considered for the track wheels.

Special publications	WL 21100	FAG special spherical roller bearings for vibratory machinery
	WL 21105	Rolling Bearings in Grinding Mills
	WL 21106	Secure handling of severe vibration · Special spherical roller bearings in vibrating screens
	WL 21107	Heavy-Duty Rolling and Plain Bearings for Mining, Processing, On- and Offshore Technology.



Market sectors

Bearing arrangements in the air handling sector

Bearing arrangements for compressors, fans and centrifuges must fulfil high requirements in relation to functional reliability and cost-efficiency. In many cases standard bearings are suitable, in some cases special bearings are required.

In order to minimise gap losses in compressors, the rolling bearing arrangement must have narrow guidance clearance.

Some compressors run at very high speeds, so particular attention must be paid to the speed capacity of the bearings. Predominantly, four point contact bearings, cylindrical roller bearings and angular contact ball bearings are used.

For bearing arrangements in smaller fans, we offer special bearing units VRE3, *Figure 16*. Depending on the load conditions, six bearing arrangement variants are available. The tubular form, unsplit plummer block housings are fitted with deep groove ball bearings, matched angular contact ball bearings and cylindrical roller bearings.



Figure 16
Plummer block housing unit VRE3
for fans

In large fans and blowers, bearings with proven success include spherical roller bearings or self-aligning ball bearings in plummer block housings SNV, LOE or LOU. Grease or oil lubrication is used according to the operating conditions.

Separators and decanters are centrifuges that can be used to separate solid materials from liquids or mixtures of liquids with simultaneous centrifuging of solids. Separation methods are used, for example, in the food and drinks industry, in chemical engineering and in environmental protection. The design of the bearing arrangement must often take account of vibrations, external temperatures and special lubrication requirements. Selection of suitable bearings is made considerably easier by use of the calculation software BEARINX®.

In many cases, cost-effective standard bearings can be used such as angular contact ball bearings and cylindrical roller bearings with sheet steel cages. By means of design using BEARINX®, a high level of functional reliability – taking account even of extreme operating conditions – is achieved.

Special publications WL 22101 Bearing technology for compressors, fans and centrifuges.

Consumer Products

Rolling bearings are present almost everywhere in our environment: at home, at work and in leisure. In most cases, however, the bearings are simply not noticed.

Rolling bearings in electrical devices are found in household appliances, in communications equipment and in DIY tools as well as in sports equipment and medical technology.

In household appliances, the requirement is normally for operation with little noise and little vibration. In order that the bearings achieve high cost-efficiency and reliability, there is a focus on long operating life and low maintenance requirements. For small devices, simple, sealed deep groove ball bearings lubricated for life are generally preferred in order to meet these requirements.

In order to avoid damage through passage of current, bearings are available with electrical insulation, *Figure 17*. In such deep groove ball bearings, cylindrical roller bearings and tapered roller bearings of variant J20., an oxide ceramic coating is applied to the outside surface and end faces of the outer ring.

Alternatively, hybrid bearings with ceramic rolling elements can be used. Hybrid deep groove ball bearings (prefix HC) with silicon nitride balls are available by agreement.

In order to detect the speed and direction of rotation in electrical devices, deep groove ball bearings with an integral sensor are available.

INA/FAG rolling bearings have also proven themselves in modern sports equipment. In motorcycles, waterjets and bob skis, their speed capacity and quiet running are particularly significant.

Low bearing friction is important where the sportsman works using muscle power, for example in bicycles and inline skates.



Figure 17
Rolling bearings with
electrical insulation

Special publications

- TI WL 43-1189 Electrically insulated rolling bearings prevent current passage damage
- TI WL 43-1206 FAG deep groove ball bearings with integral sensor
- TI WL 43-1210 FAG hybrid deep groove ball bearings.



Addresses

- Algeria** **Schaeffler KG**
FAG Region EMEA(Afrika + Irak))
Georg-Schäfer-Straße 30

Schweinfurt97421
Germany
Phone +(49) 97 21 / 91-30 85
Fax +(49) 97 21 / 91-33 47
E-mail Erich.Banz@schaeffler.com
- Andorra** **Schaeffler France**
FFC
44-48, rue Louveau - B.P. 91

Chatillon92323
France
Phone +(33) 1/40 92 16 16
Fax +(33) 1/40 92 87 57
E-mail fag@fr.fag.com
- Angola** **Schaeffler KG**
FAG Region EMEA(Afrika + Irak))
Georg-Schäfer-Straße 30

Schweinfurt97421
Germany
Phone +(49) 97 21 / 91-30 85
Fax +(49) 97 21 / 91-33 47
E-mail Erich.Banz@schaeffler.com
- Antigua and Barbuda** **Rodamientos FAG, S.A. de C.V.**
FAG Dominica
11511 Interchange Circle South

MiramarFl 33025
USA
Phone +(1) 954-7 44 34 44
Fax +(1) 954-7 44 34 76
E-mail reinhart_h@us.fag.com
- Argentina** **Schaeffler Argentina S.A.**
IRA
Avda. Alvarez Jonte 1938

Buenos AiresC1416EXR
Argentina
Phone +(54) 11 / 40 16 15 00
Fax +(54) 11 / 45 82 33 20
E-mail inaarg@ina.com.ar
- Armenia** **FAG Representative Office Ukraine**
FAG Ukraine
Ul. Schelkowitschnaja 16B, of. 29-30

Kiew01024
Ukraine
Phone +(380) 44-253 72 60
Fax +(380) 44-253 96 42
E-mail office@fag.kiev.ua
- Australia** **FAG Australia Pty Ltd**
FAG Australia Morningside
Unit 3, 47 Steel Place

Morningside4170
Australia
Phone +(61) 7 / 3399 9161
Fax +(61) 7 / 3399 9351
E-mail Alex.Jarufe@au.fag.com
- FAG Australia Pty Ltd**
FAG Australia North Balwyn
Suite 14, Level 3
74 Doncaster Road
North Balwyn3104
Australia
Phone +(61) 3 / 9859-8020
Fax +(61) 3 / 9859-8767
E-mail Milos.Grujic@au.fag.com
- FAG Australia Pty Ltd**
FAG Australia South Perth
Suite 5, 3rd Floor
78 Mill Point Road
South Perth6151
Australia
Phone +(61) 8 9368 4622
Fax +(61) 8 9367 2049
E-mail Jeff.Gordon@au.fag.com
- FAG Australia Pty Ltd.**
FAL
Level 1, Bldg 8, Forest Central Business
Park
49 Frenchs Forest Road
Frenchs Forest2086
Australia
Phone +(61) 2 8977 1000
Fax +(61) 2 9452 4242
E-mail Andreas.Pieper@au.fag.com
- Schaeffler Australia Pty Limited**
Australia
Suite 14, Level 3
74 Doncaster Road
North Balwyn3104
Australia
Phone +(61) 3 / 98 57 09 81
Fax +(61) 3 / 98 59 87 67
E-mail inavic@au.ina.com
- Schaeffler Australia Pty Limited**
IAU
142 Parraweena Road

Taren Point2229
Australia
Phone +(61) 2 / 97 10 11 00
Fax +(61) 2 / 95 40 32 99
E-mail sales@ina.au.com
- Austria** **FAG AUSTRIA AG**
FAU
Ferdinand-Pözl-Str. 2

Berndorf-St. Veit2560
Austria

INA AUSTRIA GmbH
IAV
Marktstraße 5

Vösendorf2331
Austria
Phone +(43) 1 / 69 92 54 10
Fax +(43) 1 / 6 99 25 41 55
E-mail ina.austria@at.ina.com
- Azerbaijan** **FAG Representative Office Russia**
FAG Russia
Leningradskiy pr, 37A
Bld. 14, 10. floor
Moscow125167
Russia
Phone +(7) 95 / 737 3281
Fax +(7) 95 / 737 3298
E-mail fagmoskau@col.ru

Bahamas Rodamientos FAG, S.A. de C.V.
FAG Dominica
11511 Interchange Circle South

MiramarFl 33025
USA
Phone +(1) 954-7 44 34 44
Fax +(1) 954-7 44 34 76
E-mail reinhart_h@us.fag.com

Bahrain Schaeffler KG
Region EMEA (Naher Osten)
Georg-Schäfer-Straße 30

Schweinfurt97421
Germany
Phone +(49) 97 21 / 91-35 27
Fax +(49) 97 21 / 91-33 47
E-mail Josef.Reiher@schaeffler.com

Bangladesh Schaeffler KG
Region EMEA (Ost Asien)
Georg-Schäfer-Straße 30

Schweinfurt97421
Germany
Phone +(49) 97 21 / 91-48 03
Fax +(49) 97 21 / 91-33 47
E-mail Werner.Mauder@schaeffler.com

Barbados Rodamientos FAG, S.A. de C.V.
FAG Dominica
11511 Interchange Circle South

MiramarFl 33025
USA
Phone +(1) 954-7 44 34 44
Fax +(1) 954-7 44 34 76
E-mail reinhart_h@us.fag.com

Belarus FAG International Sales and Service
FAG Belarus
4-yj Zagorodnyi per. - 58-B

Minsk220079
Belarus
Phone +(375) 17-204 11 49
Fax +(375) 17-210 24 18
E-mail fagminsk@mail.bn.by

Belgium Schaeffler Belgium S.P.R.L./B.V.B.A.
IRB
Avenue du Commerce, 38

Braine L'Alleud1420
Belgium
Phone +(32) 2 / 3 89 13 89
Fax +(32) 2 / 3 89 13 99
E-mail ina@be.ina.com

Belize Rodamientos FAG, S.A. de C.V.
FAG Dominica
11511 Interchange Circle South

MiramarFl 33025
USA
Phone +(1) 954-7 44 34 44
Fax +(1) 954-7 44 34 76
E-mail reinhart_h@us.fag.com

Benin Schaeffler KG
FAG Region EMEA(Afrika + Irak))
Georg-Schäfer-Straße 30

Schweinfurt97421
Germany
Phone +(49) 97 21 / 91-30 85
Fax +(49) 97 21 / 91-33 47
E-mail Erich.Banz@schaeffler.com

Bhutan Schaeffler KG
Region EMEA (Ost Asien)
Georg-Schäfer-Straße 30

Schweinfurt97421
Germany
Phone +(49) 97 21 / 91-48 03
Fax +(49) 97 21 / 91-33 47
E-mail Werner.Mauder@schaeffler.com

Bolivia Schaeffler Brasil Ltda.
IBR
Av. Independência, nr. 3500
Bairro Iporanga
Sorocaba18087-101
Brazil
Phone +(55) 15 / 33 35 15 00
+(55) 15 / 33 35 15 01
Fax +(55) 15 / 33 35 19 60
+(55) 15 / 33 35 19 96
E-mail dvendas@br.ina.com

Bosnia-Herzegovina INA/FAG-Repräsentanz Kroatien
IHR
Domobranska 11

Zagreb10000
Croatia
Phone +(385) 1 37 01 943
Fax +(385) 1 37 64 473
E-mail fag@fag.hr

Botswana FAG South Africa (Pty) Ltd
FSA
1 End Street Ext. Corner Heidelberg Road

Johannesburg2000
South-Africa
Phone +(27) 11 334 16 42
Fax +(27) 11 334 21 13
E-mail inquiries@ina.co.za

Brazil Rolamentos FAG S.A.
FAG Brazil Sao Paulo
Av. das Nacoes Unidas - 21.612

Sao Paulo04795-913
Brazil
Phone +(55) 11 3491 8686
Fax +(55) 11 5522 8901
E-mail industria@fag.com.br

Schaeffler Brasil Ltda.
IBR
Av. Independência, nr. 3500
Bairro Iporanga
Sorocaba18087-101
Brazil
Phone +(55) 15 / 33 35 15 00
+(55) 15 / 33 35 15 01
Fax +(55) 15 / 33 35 19 60
+(55) 15 / 33 35 19 96
E-mail dvendas@br.ina.com



Bulgaria	FAG International Sales and Service FAG Bulgaria Dondukov-Blvd. 62 A apt. 9	+ (1) 800-263-4397 Toll Free Fax + (1) 905 / 8 29 25 63 E-mail sales@ca.ina.com
	SofiaBG-1504 Bulgaria Phone + (359) 2 / 9 43 40 08 Fax + (359) 2 / 9 43 41 34 E-mail fag@fag.bg	
	INA Lageri OOD IBG PK 45	
	SofiaBG-1111 Bulgaria Phone + (359) 2 / 8 43 73 56 Fax + (359) 2 / 9 43 41 34 E-mail misho@fag.bg	
Burkina Faso	Schaeffler KG FAG Region EMEA(Afrika + Irak)) Georg-Schäfer-Straße 30	
	Schweinfurt97421 Germany Phone + (49) 97 21 / 91-30 85 Fax + (49) 97 21 / 91-33 47 E-mail Erich.Banz@schaeffler.com	
Burundi	Schaeffler KG FAG Region EMEA(Afrika + Irak)) Georg-Schäfer-Straße 30	
	Schweinfurt97421 Germany Phone + (49) 97 21 / 91-30 85 Fax + (49) 97 21 / 91-33 47 E-mail Erich.Banz@schaeffler.com	
Canada	Schaeffler Canada Inc. Canada Alberta #215, 3132 Parsons Road	
	EdmontonT6N 1L6 Canada Phone + (1) 780 / 9 89 36 50 + (1) 800-663-9006 Toll Free Fax + (1) 780 / 9 89 36 51 E-mail sales@ca.ina.com	
	Schaeffler Canada Inc. Canada Delta 1111 Cliveden Avenue	
	DeltaV3M 6G9 Canada Phone + (1) 800-665-1441 Toll Free + (1) (604) 540-4950 Fax + (1) (604) 540-7888 E-mail sales@ca.ina.com	
	Schaeffler Canada Inc. Canada Dorval 498 Lepine Avenue	
	DorvalH9P 2V6 Canada Phone + (1) 800-361-5841 Toll Free + (1) (514) 422-1125 Fax + (1) (514) 422-1020 E-mail sales@ca.ina.com	
	Schaeffler Canada Inc. ICD 2871 Plymouth Drive	
	OakvilleL6H 5S5 Canada Phone + (1) 905 / 8 29 27 50	
Central African Republic	Schaeffler KG FAG Region EMEA(Afrika + Irak)) Georg-Schäfer-Straße 30	
	Schweinfurt97421 Germany Phone + (49) 97 21 / 91-30 85 Fax + (49) 97 21 / 91-33 47 E-mail Erich.Banz@schaeffler.com	
Chad	Schaeffler KG FAG Region EMEA(Afrika + Irak)) Georg-Schäfer-Straße 30	
	Schweinfurt97421 Germany Phone + (49) 97 21 / 91-30 85 Fax + (49) 97 21 / 91-33 47 E-mail Erich.Banz@schaeffler.com	
Chile	Schaeffler Brasil Ltda. IBR Av. Independência, nr. 3500 Bairro Iporanga Sorocaba18087-101 Brazil	
	Phone + (55) 15 / 33 35 15 00 + (55) 15 / 33 35 15 01 Fax + (55) 15 / 33 35 19 60 + (55) 15 / 33 35 19 96 E-mail dvendas@br.ina.com	
China	FAG China Company Limited FAG China Beijing Room 711, Scitech Tower 22 Jianguomenwai Avenue Beijing100004 China	
	Phone + (86) 10/6515 0288 Fax + (86) 10/6512-3433 E-mail sales_bj@cn.fag.com	
	FAG China Company Limited FAG China Chengdu Rm 2408, Sichuan CBC Building 88 Tidu Street Chengdu Sichuan610016 China	
	Phone + (86) 28-8676-6718 Fax + (86) 28 8676-6728 E-mail sales_cd@cn.fag.com	
	FAG China Company Limited FAG China Guangzhou Room 1505A Goldlion Digital Network Centre - 138 Ti Yu Road East Guangzhou510620 China	
	Phone + (86) 20-3878-1001 Fax + (86) 20-3878-1667 E-mail sales_gz@cn.fag.com	
	FAG China Company Limited FAG China Hong Kong Unit 2501, 25/F, Tower Two Lippo Centre, 89 Queensway Hong Kong China	
	Phone + (86) 2371/2680 Fax + (86) 2371/2112 E-mail sales_hk@cn.fag.com	

FAG China Company Limited

FAG China Shanghai
 Room 905 Central Plaza
 227 Huang Pi Bei Lu
 Shanghai 200003
 China
 Phone + (86) 21/6375-8235
 Fax + (86) 21/6375-8237
 E-mail sales_sh@cn.fag.com

Schaeffler (China) Co Ltd. Nanjing Office

FAG China Nanjing
 Room 1503, Ramada Plaza
 No.45 North Zhong shan Road
 Nanjing 210008
 China
 Phone + (86) 25/469-2776
 Fax + (86) 25/469-1686
 E-mail sales_nj@cn.fag.com

Schaeffler (China) Co. Ltd. Beijing Office

Beijing China
 Room 708, Scitech Tower No.22
 Jianguomenwai Avenue
 Beijing 100004
 China
 Phone + (86) 10 / 65 18 38 29
 Fax + (86) 10 / 65 18 38 31
 E-mail inabj@public.bta.net.cn

Schaeffler (China) Co. Ltd. Guangzhou Office

Guangzhou China
 Room 1505B, Goldion Digital Network
 Centre
 138 Ti Yu Road
 East Guangzhou 510260
 China
 Phone + (86) 20 / 87 60 72 99
 Fax + (86) 20 / 87 61 00 32
 E-mail inagz@hotmail.com

Schaeffler (China) Co. Ltd. Ji'nan Office

Ji'nan China
 CITIC Plaza
 No.150 Luo Yuan Street
 Ji'nan Shandong 250011
 China

Schaeffler (China) Co. Ltd. Shenyang Office

Shenyang China
 ??????????219??????14?HI??
 Unit H/I 14F, Huaxin International Tower
 No.219 Qingnian Street, Shenhe District
 Shenyang 110015
 China
 Phone + (86) 24 / 23962633
 Fax + (86) 24 / 23962533
 E-mail lweiqun@online.ln.cn

Schaeffler (China) Co., Ltd.

IZT
 18 Chaoyang Road, Jiangsu Province
 Economical Development Area
 Taicang 215400
 China
 Phone + (86) 512 / 5395 7700
 Fax + (86) 512 / 5357 4064
 E-mail min.wang@cn.ina.com

Colombia FAG Interamericana AG - Area Colombia-

Ecuador
 Colombia
 Calle 93 B - No. 11A-44
 Oficina 201
 Bogotá
 Colombia
 Phone + (57) 1 / 6 21 09 99
 Fax + (57) 1 / 2 57 24 60
 E-mail fagintkalozdi@andinet.com

FAG Interamericana AG - Delegación II

FAG Columbia Cali
 Cali Av. 2 Norte - No. 23A-11 - Oficina 208
 - Edificio Unimed
 Cali
 Colombia
 Phone + (57) 2 / 667 98 52
 Fax + (57) 2 / 661 64 20
 E-mail fagintgonzalez@andinet.com

Costa Rica Rodamientos FAG, S.A. de C.V.

FAG Dominica
 11511 Interchange Circle South
 Miramar Fl 33025
 USA
 Phone + (1) 954-7 44 34 44
 Fax + (1) 954-7 44 34 76
 E-mail reinhart_h@us.fag.com

Croatia INA/FAG-Repräsentanz Kroatien

IHR
 Domobranska 11
 Zagreb 10000
 Croatia
 Phone + (385) 1 37 01 943
 Fax + (385) 1 37 64 473
 E-mail fag@fag.hr

Cuba Rodamientos FAG S.A. de C.V.

FAG Mexico Region Mittelamerika
 Paseo de la Reforma 383 - Despacho 701
 y 702
 Colonia Cuauhtemoc
 Mexico D.F. DF 06500
 Mexico
 Phone + (52) 55-52 08 12 08
 Fax + (52) 55 52 08 08 36
 E-mail Pubanz_t@us.fag.com

Czech Republic FAG International Sales and Service

FAG Czechia Ostrava
 Nádražní 176/42
 Ostrava 702 00
 Czech Republic
 Phone + (42) 59-6133 278
 Fax + (42) 59-6115 508
 E-mail fag@fag.cz

FAG International Sales and Service

FAG Czechia Praha
 Prubezná 74a
 Praha 10100 00
 Czech Republic
 Phone + (42) 2 / 6729 8231
 Fax + (42) 2 / 7477 5701
 E-mail fag@fag.cz

INA Loziska s r.o.

ICZ
 Prubezná 74a
 Praha 10100 00
 Czech Republic
 Phone + (42) 267 298 111
 Fax + (42) 267 298 110
 E-mail inaloziska@cz.ina.com



Denmark	<p>Schaeffler Danmark ApS FAD Jens Baggesens Vej 90P</p> <p>Aarhus N8200 Denmark Phone + (45) 70 15 44 44 Fax + (45) 70 15 22 02 E-mail schaeffler.dk@schaeffler.com</p>	Eritrea	<p>Schaeffler KG FAG Region EMEA(Afrika + Irak)) Georg-Schäfer-Straße 30</p> <p>Schweinfurt97421 Germany Phone + (49) 97 21 / 91-30 85 Fax + (49) 97 21 / 91-33 47 E-mail Erich.Banz@schaeffler.com</p>
Djibouti	<p>Schaeffler KG FAG Region EMEA(Afrika + Irak)) Georg-Schäfer-Straße 30</p> <p>Schweinfurt97421 Germany Phone + (49) 97 21 / 91-30 85 Fax + (49) 97 21 / 91-33 47 E-mail Erich.Banz@schaeffler.com</p>	Estonia	<p>INA/FAG-Repräsentanz Baltikum Latvija K.Ulmana gatve 119</p> <p>Riga2167 Latvia Phone + (371) 7 06 37 95 Fax + (371) 7 06 37 96 E-mail info@ina.lv kaspars.strelcs@ina.lv</p>
Dominica	<p>Rodamientos FAG, S.A. de C.V. FAG Dominica 11511 Interchange Circle South</p> <p>MiramarFl 33025 USA Phone + (1) 954-7 44 34 44 Fax + (1) 954-7 44 34 76 E-mail reinhart_h@us.fag.com</p>	Ethiopia	<p>Schaeffler KG FAG Region EMEA(Afrika + Irak)) Georg-Schäfer-Straße 30</p> <p>Schweinfurt97421 Germany Phone + (49) 97 21 / 91-30 85 Fax + (49) 97 21 / 91-33 47 E-mail Erich.Banz@schaeffler.com</p>
Ecuador	<p>FAG Interamericana AG - Area Colombia-Ecuador Columbia Calle 93 B - No. 11A-44 Oficina 201 Bogotá Colombia Phone + (57) 1 / 6 21 09 99 Fax + (57) 1 / 2 57 24 60 E-mail fagintkalozdi@andinet.com</p>	Fiji	<p>FAG New Zealand FAG New Zealand Auckland 6 Te Apunga Place Mt Wellington Auckland1706 New Zealand Phone + (64) 9 270 1837 Fax + (64) 9 270 1839 E-mail David.Nevin@au.fag.com</p>
Egypt	<p>Delegation Office Schaeffler KG FAG EGYPT Obour Buildings-Salah Salem St.-No.25 - Floor 18-Flat 4</p> <p>Nasr City Cairo11811 Egypt Phone + (20) 24 01 24 32 + (20) 22 61 26 37 Fax + (20) 22 61 26 37 + (20) 24 01 24 32 E-mail fagegypt@thewayout.net</p>	Finland	<p>Schaeffler Finland Oy IFI und FFE Lautamiehentie 3</p> <p>Espoo02770 Finland Phone + (358) 207 / 36 6204 Fax + (358) 207 36 6205 E-mail ina@fi.ina.com</p>
El Salvador	<p>Rodamientos FAG, S.A. de C.V. FAG Dominica 11511 Interchange Circle South</p> <p>MiramarFl 33025 USA Phone + (1) 954-7 44 34 44 Fax + (1) 954-7 44 34 76 E-mail reinhart_h@us.fag.com</p>	France	<p>Schaeffler France FFC 44-48, rue Louveau - B.P. 91</p> <p>Chatillon92323 France Phone + (33) 1/40 92 16 16 Fax + (33) 1/40 92 87 57 E-mail fag@fr.fag.com</p> <p>Schaeffler France ICF 93, route de Bitche, BP 30186</p> <p>Haguenau67506 France Phone + (33) 3 88 63 40 40 Fax + (33) 3 88 63 40 41 E-mail Stephan.Buffler@fr.ina.com</p>
Equatorial Guinea	<p>Schaeffler KG FAG Region EMEA(Afrika + Irak)) Georg-Schäfer-Straße 30</p> <p>Schweinfurt97421 Germany Phone + (49) 97 21 / 91-30 85 Fax + (49) 97 21 / 91-33 47 E-mail Erich.Banz@schaeffler.com</p>		

Gabon	<p>Schaeffler KG FAG Region EMEA(Afrika + Irak) Georg-Schäfer-Straße 30</p> <p>Schweinfurt97421 Germany Phone +(49) 97 21 / 91-30 85 Fax +(49) 97 21 / 91-33 47 E-mail Erich.Banz@schaeffler.com</p>	<p>The Barden Corporation (U.K.) Limited BCP Plymbridge Road - Estover</p> <p>PlymouthPL6 7LH Great Britain Phone +(44) 1752 73 55 55 Fax +(44) 1752 73 34 81 E-mail sales@barden.co.uk</p>
Gambia	<p>Schaeffler KG FAG Region EMEA(Afrika + Irak) Georg-Schäfer-Straße 30</p> <p>Schweinfurt97421 Germany Phone +(49) 97 21 / 91-30 85 Fax +(49) 97 21 / 91-33 47 E-mail Erich.Banz@schaeffler.com</p>	Guatemala
Georgia	<p>FAG Representative Office Russia FAG Russia Leningradskiy pr, 37A Bld. 14, 10. floor Moscow125167 Russia Phone +(7) 95 / 737 3281 Fax +(7) 95 / 737 3298 E-mail fagmoskau@col.ru</p>	<p>Rodamientos FAG S.A. de C.V. FAG Mexico Region Mittelamerika Paseo de la Reforma 383 - Despacho 701 y 702 Colonia Cuauhtemoc Mexico D.F.DF 06500 Mexico Phone +(52) 55-52 08 12 08 Fax +(52) 55 52 08 08 36 E-mail Pubanz_t@us.fag.com</p>
Germany	<p>REGE Motorenteile GmbH & Co. KG REG Industriestraße 4 Industriegebiet Eisenach/Kindel</p> <p>Hörselberg99819 Germany Phone +(49) 36 920 / 12-0 Fax +(49) 36 920 / 12-3 09</p> <p>Schaeffler KG FAG Georg-Schäfer-Str. 30</p> <p>Schweinfurt97421 Germany Phone +(49) (9721) 91-0 Fax +(49) (9721) 91-3435 E-mail public_relations@fag.de</p> <p>Schaeffler KG IDH Industriestraße 1-3</p> <p>Herzogenaurach91074 Germany Phone +(49) 91 32 / 82 0 Fax +(49) 91 32 / 82 49 50 E-mail info@de.ina.com</p>	Guinea
Ghana	<p>Schaeffler KG FAG Region EMEA(Afrika + Irak) Georg-Schäfer-Straße 30</p> <p>Schweinfurt97421 Germany Phone +(49) 97 21 / 91-30 85 Fax +(49) 97 21 / 91-33 47 E-mail Erich.Banz@schaeffler.com</p>	<p>Schaeffler KG FAG Region EMEA(Afrika + Irak) Georg-Schäfer-Straße 30</p> <p>Schweinfurt97421 Germany Phone +(49) 97 21 / 91-30 85 Fax +(49) 97 21 / 91-33 47 E-mail Erich.Banz@schaeffler.com</p>
Great Britain	<p>Schaeffler (UK) Ltd IBL Forge Lane, Minworth</p> <p>Sutton ColdfieldB76 1AP Great Britain Phone +(44) 121 / 3 51 38 33 Fax +(44) 121 / 3 51 76 86 E-mail ina.bearing@uk.ina.com</p>	<p>Schaeffler Brasil Ltda. IBR Av. Independência, nr. 3500 Bairro Iporanga Sorocaba18087-101 Brazil Phone +(55) 15 / 33 35 15 00 +(55) 15 / 33 35 15 01 Fax +(55) 15 / 33 35 19 60 +(55) 15 / 33 35 19 96 E-mail dvendas@br.ina.com</p>
		Honduras
		<p>Rodamientos FAG, S.A. de C.V. FAG Dominica 11511 Interchange Circle South</p> <p>MiramarFl 33025 USA Phone +(1) 954-7 44 34 44 Fax +(1) 954-7 44 34 76 E-mail reinhart_h@us.fag.com</p>
		Haiti
		<p>Rodamientos FAG, S.A. de C.V. FAG Dominica 11511 Interchange Circle South</p> <p>MiramarFl 33025 USA Phone +(1) 954-7 44 34 44 Fax +(1) 954-7 44 34 76 E-mail reinhart_h@us.fag.com</p>



Hungary FAG International Sales and Service

FAG Hungary
Infopark Sétány
Neumann János u.1. Gebaeude B
Budapest1117
Hungary
Phone +(36) 1 203-3831
+(36) 1 / 203-3830
Fax +(36) 1 203 3828
E-mail fag@fag.hu

INA Gördülöcsapágy Kft.

IWU
Neuman János út 1/B fsz.

Budapest1117
Hungary
Phone +(36) 1 / 4 81 30 50
Fax +(36) 1 / 4 81 30 53
E-mail beata.kovacs@hu.ina.com

Iceland Schaeffler Belgium S.P.R.L./B.V.B.A.

IRB
Avenue du Commerce, 38

Braine L'Alleud1420
Belgium
Phone +(32) 2 / 3 89 13 89
Fax +(32) 2 / 3 89 13 99
E-mail ina@be.ina.com

India FAG Bearings India Limited

FAG India Bangalore
18, Gr. Floor, Wst View
77, R.V. Road, Basavanagudi
Bangalore560 004
India
Phone +(91) 80 26574866
Fax +(91) 80 26574866
E-mail gummakis@fag.co.in

FAG Bearings India Limited

FAG India Chennai
710, 7th Floor, Phase II, Spencer Plaza,
769 - Anna Salai
Chennai600 002
India
Phone +(91) 44 28 4935-82/-83/-84/-85
Fax +(91) 44 28497577
E-mail pattabhi@fag.co.in

FAG Bearings India Limited

FAG India Kolkata
Jasmine Towers, 5th Floor
Room No. 502B, 31, Shakespeare Sarani
Kolkata700 017
India
Phone +(91) 33 22 8900-26/-27/-96
Fax +(91) 33 22 89 00 95
E-mail nambiar@fag.co.in

FAG Bearings India Limited

FAG India Mumbai
Nariman Bhavan, 8th Floor, 227, Backbay
Reclamation Nariman Point

Mumbai400 021
India
Phone +(91) 22 - 2022 144/ -166/ -362
Fax +(91) 22 - 2027022
E-mail muralik@fag.co.in

FAG Bearings India Limited

FAG India New Dehli
B-1504, Statesman House, 148, Barak-
hamba Road

New Dehli110 001
India
Phone +(91) 78 / 8521476

+(91) 11 - 3738276

Fax +(91) 11 - 8521478

E-mail purim@fag.co.in

FAG Bearings India Limited

FBI
Maneja

Vadodara390 013
India
Phone +(91) 265 - 26426 51-2-3-4
Fax +(91) 265 - 2638804
E-mail mathurr@fag.co.in

FAG Bearings India Limited

FRI
103 - Akshay Complex - Dhole Patil Road

Pune411 011

India
Phone +(91) 20 560228-18/-19
Fax +(91) 20 - 6122229
E-mail sumanaha@fag.co.in

INA Bearings India Pvt. Ltd.

IBI
Indo-Germany Technology Park, Survey
No. 297/298/299
Village-Urawade, Tal. Mulshi
Pune412 108
India
Phone +(91) 20 66520216 Ext 127
Fax +(91) 20 66524756
E-mail Swapnil.Badkur@schaeffler.com

INA Bearings India Pvt. Ltd.

India Bangalore
200, 3rd Main
6th Cross, Mico Layout
Bangalore560076
India
Phone +(91) 80 2668 5516
Fax +(91) 80 2668 9986
E-mail ina.bangalore@vsnl.com

INA Bearings India Pvt. Ltd.

India New Dehli
A-322
Ansal Chamber-1, 3, Bhikaji Cama Place
New Delhi110066
India
Phone +(91) 11 26712413
Fax +(91) 11 26712412
E-mail inadelhi@vsnl.net

Iran FAG Coordination Office Teheran

FAG Iran
No 43/4 Soleiman Khater Ave
Malayeri Pour Cross Rd, 7th of Tir Square
Teheran15797
Iran
Phone +(98) 21- 883 63 51
Fax +(98) 21- 830 88 13
E-mail fagiran@safineh.net

Iraq Schaeffler KG

FAG Region EMEA(Afrika + Irak))
Georg-Schäfer-Straße 30
Schweinfurt97421
Germany
Phone +(49) 97 21 / 91-30 85
Fax +(49) 97 21 / 91-33 47
E-mail Erich.Banz@schaeffler.com

Israel	<p>Schaeffler KG Region EMEA (Nahe Osten) Georg-Schäfer-Straße 30</p> <p>Schweinfurt97421 Germany Phone +(49) 97 21 / 91-35 27 Fax +(49) 97 21 / 91-33 47 E-mail Josef.Reiher@schaeffler.com</p>	<p>INA Korea Corp. Changwon office Korea 102-1 Chungang-dong Changwon-shi Kyongsangnam-do641-030 Korea Phone +(82) 55 / 2 75 14 10 Fax +(82) 55 / 2 75 25 53 E-mail Yonguk.Kwon@kr.ina.com</p>
Italy	<p>INA Italia S.r.l. IRM Strada Regionale 229 Km 17</p> <p>Momo28015 Italy Phone +(39) 3 21 / 92 92 11 Fax +(39) 3 21 / 92 93 00 E-mail marketing@it.ina.com</p> <p>WPB Water Pump Bearing GmbH & Co. KG WPB Strada Regionale 229 Km 17</p> <p>Momo28015 Italy Phone +(39) 03 21 / 92 85 03 Fax +(39) 03 21 / 92 89 00</p>	<p>Korea, Democratic People's Republic of</p> <p>FAG China Company Limited FAG China Hong Kong Unit 2501, 25/F, Tower Two Lippo Centre, 89 Queensway Hong Kong China Phone +(86) 2371/2680 Fax +(86) 2371/2112 E-mail sales_hk@cn.fag.com</p>
Ivory Coast	<p>Schaeffler KG FAG Region EMEA(Afrika + Irak)) Georg-Schäfer-Straße 30</p> <p>Schweinfurt97421 Germany Phone +(49) 97 21 / 91-30 85 Fax +(49) 97 21 / 91-33 47 E-mail Erich.Banz@schaeffler.com</p>	<p>Latvia</p> <p>INA/FAG-Repräsentanz Baltikum Latvija K.Ulmana gatve 119</p> <p>Riga2167 Latvia Phone +(371) 7 06 37 95 Fax +(371) 7 06 37 96 E-mail info@ina.lv kaspars.strelcs@ina.lv</p>
Japan	<p>Schaeffler Japan Co., Ltd. FJT Square Building 2-3-12 Shinyokohama, Kohoku-ku Yokohama222-0033 Japan Phone +(81) 45 / 478 2004 Fax +(81) 45 / 478 2014 E-mail fagjapan@mb.infoweb.ne.jp</p> <p>Schaeffler Japan Co., Ltd. IBJ Square Building 15F 2-3-12, Shin-Yokohama, Kohoku-ku Yokohama222-0033 Japan</p>	<p>Lesotho</p> <p>FAG South Africa (Pty) Ltd FSA 1 End Street Ext. Corner Heidelberg Road</p> <p>Johannesburg2000 South-Africa Phone +(27) 11 334 16 42 Fax +(27) 11 334 21 13 E-mail inquiries@ina.co.za</p>
Korea	<p>FAG Bearings Korea Corp. Seoul Main Office FAG Korea Seoul Samsung Fire-Marine Insurance Bldg., 11-12F #87, Euljiro-1ga, Jung-gu Seoul100-191 Korea Phone +(82) 2-311-3000 Fax +(82) 2-311-3050 E-mail jaehun.kim@schaeffler.com</p> <p>INA Korea Corp. IKI 1054-2 Shingil-dong Ansan-shi Kyonggi-do425-020 Korea Phone +(82) 2 / 311-3098 Fax +(82) 2 / 311-3054 E-mail yonguk.kwon@schaeffler.com</p>	<p>Liberia</p> <p>Schaeffler KG FAG Region EMEA(Afrika + Irak)) Georg-Schäfer-Straße 30</p> <p>Schweinfurt97421 Germany Phone +(49) 97 21 / 91-30 85 Fax +(49) 97 21 / 91-33 47 E-mail Erich.Banz@schaeffler.com</p>
		<p>Libya</p> <p>Schaeffler KG FAG Region EMEA(Afrika + Irak)) Georg-Schäfer-Straße 30</p> <p>Schweinfurt97421 Germany Phone +(49) 97 21 / 91-30 85 Fax +(49) 97 21 / 91-33 47 E-mail Erich.Banz@schaeffler.com</p>
		<p>Lithuania</p> <p>INA/FAG-Repräsentanz Baltikum Latvija K.Ulmana gatve 119</p> <p>Riga2167 Latvia Phone +(371) 7 06 37 95 Fax +(371) 7 06 37 96 E-mail info@ina.lv kaspars.strelcs@ina.lv</p>



Luxembourg	<p>Schaeffler Belgium S.P.R.L./B.V.B.A. IRB Avenue du Commerce, 38</p> <p>Braine L'Alleud1420 Belgium Phone +(32) 2 / 3 89 13 89 Fax +(32) 2 / 3 89 13 99 E-mail ina@be.ina.com</p>	Malta	<p>Schaeffler KG Region EMEA (Naher Osten) Georg-Schäfer-Straße 30</p> <p>Schweinfurt97421 Germany Phone +(49) 97 21 / 91-35 27 Fax +(49) 97 21 / 91-33 47 E-mail Josef.Reiher@schaeffler.com</p>
Macedonia	<p>Schaeffler KG Region Mazedonien Georg-Schäfer-Straße 30</p> <p>Schweinfurt97421 Germany Phone +(49) 97 21 / 91-32 73 Fax +(49) 97 21 / 91-39 48 E-mail Anita.Buehner@schaeffler.com</p>	Marocco	<p>Schaeffler KG FAG Region EMEA(Afrika + Irak)) Georg-Schäfer-Straße 30</p> <p>Schweinfurt97421 Germany Phone +(49) 97 21 / 91-30 85 Fax +(49) 97 21 / 91-33 47 E-mail Erich.Banz@schaeffler.com</p>
Madagascar	<p>Schaeffler KG FAG Region EMEA(Afrika + Irak)) Georg-Schäfer-Straße 30</p> <p>Schweinfurt97421 Germany Phone +(49) 97 21 / 91-30 85 Fax +(49) 97 21 / 91-33 47 E-mail Erich.Banz@schaeffler.com</p>	Marshall-Islands	<p>FAG New Zealand FAG New Zealand Auckland 6 Te Apunga Place Mt Wellington Auckland1706 New Zealand Phone +(64) 9 270 1837 Fax +(64) 9 270 1839 E-mail David.Nevin@au.fag.com</p>
Malawi	<p>FAG South Africa (Pty) Ltd FSA 1 End Street Ext. Corner Heidelberg Road</p> <p>Johannesburg2000 South-Africa Phone +(27) 11 334 16 42 Fax +(27) 11 334 21 13 E-mail inquiries@ina.co.za</p>	Mauritania	<p>Schaeffler KG FAG Region EMEA(Afrika + Irak)) Georg-Schäfer-Straße 30</p> <p>Schweinfurt97421 Germany Phone +(49) 97 21 / 91-30 85 Fax +(49) 97 21 / 91-33 47 E-mail Erich.Banz@schaeffler.com</p>
Malaysia	<p>Schaeffler Bearings (Malaysia) Sdn. Bhd. FAG Malaysia 8A1, 8th flr Sungai Mas Plaza - 5th Miles - Jalan Ipoh</p> <p>Kuala Lumpur Malaysia Phone +(60) 3-62581620 Fax +(60) 3-62581614 E-mail lee_sl@my.fag.com</p>	Mauritius	<p>FAG South Africa (Pty) Ltd FSA 1 End Street Ext. Corner Heidelberg Road</p> <p>Johannesburg2000 South-Africa Phone +(27) 11 334 16 42 Fax +(27) 11 334 21 13 E-mail inquiries@ina.co.za</p>
Maldives	<p>Schaeffler KG Region EMEA (Ost Asien) Georg-Schäfer-Straße 30</p> <p>Schweinfurt97421 Germany Phone +(49) 97 21 / 91-48 03 Fax +(49) 97 21 / 91-33 47 E-mail Werner.Mauder@schaeffler.com</p>	Mexico	<p>INA Mexico, S.A. de C.V. IMX Paseo de la Reforma 383, int.704 Col. Cuahtemoc Mexico D.F.06500 Mexico Phone +(52) 55 / 55 25 00 12 Fax +(52) 55 / 55 25 01 94 E-mail eduardo.zapata@mx.ina.com</p> <p>Rodamientos FAG S.A. de C.V. FRM Paseo de la Reforma 383 Colonia Cuahtémoc Mexico D.F.06500 Mexico Phone +(52) 55 5208-1208 +(52) 55 5208-0961 +(52) 55 08-0571 Fax +(52) 55 5208-0836</p>
Mali	<p>Schaeffler KG FAG Region EMEA(Afrika + Irak)) Georg-Schäfer-Straße 30</p> <p>Schweinfurt97421 Germany Phone +(49) 97 21 / 91-30 85 Fax +(49) 97 21 / 91-33 47 E-mail Erich.Banz@schaeffler.com</p>		

Micronesia	FAG New Zealand FAG New Zealand Auckland 6 Te Apunga Place Mt Wellington Auckland1706 New Zealand Phone +(64) 9 270 1837 Fax +(64) 9 270 1839 E-mail David.Nevin@au.fag.com	Nepal	Schaeffler KG Region EMEA (Ost Asien) Georg-Schäfer-Straße 30 Schweinfurt97421 Germany Phone +(49) 97 21 / 91-48 03 Fax +(49) 97 21 / 91-33 47 E-mail Werner.Mauder@schaeffler.com
Moldova	FAG Representative Office Ukraine FAG Ukraine Ul. Schelkowitzchnaja 16B, of. 29-30 Kiew01024 Ukraine Phone +(380) 44-253 72 60 Fax +(380) 44-253 96 42 E-mail office@fag.kiev.ua	Netherlands	Schaeffler Nederland B.V. INL Gildeweg 31 Barneveld3771 NB Netherlands Phone +(31) 342 / 40 30 00 Fax +(31) 342 / 40 32 80 E-mail info@ina.nl
Monaco	Schaeffler France FFC 44-48, rue Louveau - B.P. 91 Chatillon92323 France Phone +(33) 1/40 92 16 16 Fax +(33) 1/40 92 87 57 E-mail fag@fr.fag.com	New Zealand	FAG New Zealand FAG New Zealand Auckland 6 Te Apunga Place Mt Wellington Auckland1706 New Zealand Phone +(64) 9 270 1837 Fax +(64) 9 270 1839 E-mail David.Nevin@au.fag.com
Mongolia	FAG China Company Limited FAG China Hong Kong Unit 2501, 25/F, Tower Two Lippo Centre, 89 Queensway Hong Kong China Phone +(86) 2371/2680 Fax +(86) 2371/2112 E-mail sales_hk@cn.fag.com	Nicaragua	Rodamientos FAG, S.A. de C.V. FAG Dominica 11511 Interchange Circle South MiramarFl 33025 USA Phone +(1) 954-7 44 34 44 Fax +(1) 954-7 44 34 76 E-mail reinhart_h@us.fag.com
Mozambique	FAG South Africa (Pty) Ltd FSA 1 End Street Ext. Corner Heidelberg Road Johannesburg2000 South-Africa Phone +(27) 11 334 16 42 Fax +(27) 11 334 21 13 E-mail inquiries@ina.co.za	Niger	Schaeffler KG FAG Region EMEA(Afrika + Irak)) Georg-Schäfer-Straße 30 Schweinfurt97421 Germany Phone +(49) 97 21 / 91-30 85 Fax +(49) 97 21 / 91-33 47 E-mail Erich.Banz@schaeffler.com
Namibia	FAG South Africa (Pty) Ltd FSA 1 End Street Ext. Corner Heidelberg Road Johannesburg2000 South-Africa Phone +(27) 11 334 16 42 Fax +(27) 11 334 21 13 E-mail inquiries@ina.co.za	Nigeria	Schaeffler KG FAG Region EMEA(Afrika + Irak)) Georg-Schäfer-Straße 30 Schweinfurt97421 Germany Phone +(49) 97 21 / 91-30 85 Fax +(49) 97 21 / 91-33 47 E-mail Erich.Banz@schaeffler.com
Nauru	FAG New Zealand FAG New Zealand Auckland 6 Te Apunga Place Mt Wellington Auckland1706 New Zealand Phone +(64) 9 270 1837 Fax +(64) 9 270 1839 E-mail David.Nevin@au.fag.com	Norway	Schaeffler Norge AS INN Nils Hansens vei 2 Oslo0604 Norway Phone +(47) 23 24 93 30 Fax +(47) 23 24 93 31 E-mail post@no.ina.com



- Oman** **Schaeffler KG**
Region EMEA (Naher Osten)
Georg-Schäfer-Straße 30

Schweinfurt97421
Germany
Phone +(49) 97 21 / 91-35 27
Fax +(49) 97 21 / 91-33 47
E-mail Josef.Reiher@schaeffler.com
- Palau** **FAG New Zealand**
FAG New Zealand Auckland
6 Te Apunga Place
Mt Wellington
Auckland1706
New Zealand
Phone +(64) 9 270 1837
Fax +(64) 9 270 1839
E-mail David.Nevin@au.fag.com
- Panama** **Rodamientos FAG, S.A. de C.V.**
FAG Dominica
11511 Interchange Circle South

MiramarFL 33025
USA
Phone +(1) 954-7 44 34 44
Fax +(1) 954-7 44 34 76
E-mail reinhart_h@us.fag.com
- Papua New Guinea** **FAG Australia Pty Ltd**
FAG Australia Forestville
PO Box 234

Forestville2087
Australia
Phone +(61) 2-89 77 10 00
Fax +(61) 2-94 52 42 42
E-mail Rod_A@au.fag.com
- Paraguay** **Schaeffler Brasil Ltda.**
IBR
Av. Independência, nr. 3500
Bairro Iporanga
Sorocaba18087-101
Brazil
Phone +(55) 15 / 33 35 15 00
+(55) 15 / 33 35 15 01
Fax +(55) 15 / 33 35 19 60
+(55) 15 / 33 35 19 96
E-mail dvendas@br.ina.com
- Peru** **Schaeffler Brasil Ltda.**
IBR
Av. Independência, nr. 3500
Bairro Iporanga
Sorocaba18087-101
Brazil
Phone +(55) 15 / 33 35 15 00
+(55) 15 / 33 35 15 01
Fax +(55) 15 / 33 35 19 60
+(55) 15 / 33 35 19 96
E-mail dvendas@br.ina.com
- Philippines** **FAG Representative Office Philippines**
FAG Philippines Manila
UG19 City Square Building - 6264 Estacion Street

Makati City - Metro Manila1230
Philippines
Phone +(63) 2-751-8806
Fax +(63) 2-751-8807
E-mail brian.davis@ph.fag.com
- Poland** **FAG International Sales and Service**
FAG Poland Ruda Slaska-Halemba
Ul. Armii Krajowej 27

Ruda Slaska41-706
Poland
Phone +(48) 32 / 24 08 516
Fax +(48) 32 / 24 08 516
E-mail borowy_a@fag.pl

FAG International Sales and Service
FAG Poland Warszawa
Ul. Szyszkowa 35/37 (Gebäude E)

WarszawaPL 02-285
Poland
Phone +(48) 22 / 878 31 60
Fax +(48) 22 / 878 31 62
E-mail fag@fag.pl

INA Lozyska Spolka z o.o.
IPL
Budynek E
ul. Szyszkowa 35/37
Warszawa02-285
Poland
Phone +(48) 22 / 8 78 41 20
Fax +(48) 22 / 8 78 41 22
E-mail ewa.bienkowska@pl.ina.com
- Portugal** **INA Rolamentos Lda.**
IRP
Av. Fontes Pereira de Melo, 470

Porto4149-012
Portugal
Phone +(351) 22 / 5 32 08 90
Fax +(351) 22 / 5 32 08 61
E-mail marketing@pt.ina.com
- Romania** **FAG International Sales and Service**
FAG Romania
Bulevardul Ion Mihalache Nr. 58
Bl. 35A, Sc. A, Et. 6, Ap. 28. Sector 1
BucurestiR-782151
Romania
Phone +(40) 21 / 222 83 12
Fax +(40) 21 / 222 82 31
E-mail fag@fag.ro
- Russia** **FAG International Sales and Service**
FAG Russia
Ul. Tjuschina 4-6

St. Petersburg191 119
Russia
Phone +(7) 812 / 325 22 92
Fax +(7) 812 / 325 22 93
E-mail fag@fag.spb.ru

FAG Representative Office Russia
FAG Russia
Leningradskiy pr, 37A
Bld. 14, 10. floor
Moscow125167
Russia
Phone +(7) 95 / 737 3281
Fax +(7) 95 / 737 3298
E-mail fagmoskau@col.ru

INA Moscow
Russia
Leningradsky Prospekt 37A, Korp.14

Moscow125167
Russia
Phone +(7) 95 / 7 37 76 60
Fax +(7) 95 / 7 37 76 53
E-mail inarussia@col.ru

Rwanda	<p>Schaeffler KG FAG Region EMEA(Afrika + Irak) Georg-Schäfer-Straße 30</p> <p>Schweinfurt97421 Germany Phone +(49) 97 21 / 91-30 85 Fax +(49) 97 21 / 91-33 47 E-mail Erich.Banz@schaeffler.com</p>	Seychelles	<p>FAG South Africa (Pty) Ltd FSA 1 End Street Ext. Corner Heidelberg Road</p> <p>Johannesburg2000 South-Africa Phone +(27) 11 334 16 42 Fax +(27) 11 334 21 13 E-mail inquiries@ina.co.za</p>
Saint Lucia	<p>Rodamientos FAG, S.A. de C.V. FAG Dominica 11511 Interchange Circle South</p> <p>MiramarFl 33025 USA Phone +(1) 954-7 44 34 44 Fax +(1) 954-7 44 34 76 E-mail reinhart_h@us.fag.com</p>	Sierra Leone	<p>Schaeffler KG FAG Region EMEA(Afrika + Irak) Georg-Schäfer-Straße 30</p> <p>Schweinfurt97421 Germany Phone +(49) 97 21 / 91-30 85 Fax +(49) 97 21 / 91-33 47 E-mail Erich.Banz@schaeffler.com</p>
Samoa-West	<p>FAG New Zealand FAG New Zealand Auckland 6 Te Apunga Place Mt Wellington Auckland1706 New Zealand Phone +(64) 9 270 1837 Fax +(64) 9 270 1839 E-mail David.Nevin@au.fag.com</p>	Singapore	<p>INA / FAG South East Asia (Singapore) SGP New Tech Park @ 151 Lorong Chuan #06-01</p> <p>Singapore556741 Singapore Phone +(65) 6540 8600 Fax +(65) 6540 8668 E-mail yeeling.ng@sg.ina.com</p>
Sao Tome and Principe	<p>Schaeffler KG FAG Region EMEA(Afrika + Irak) Georg-Schäfer-Straße 30</p> <p>Schweinfurt97421 Germany Phone +(49) 97 21 / 91-30 85 Fax +(49) 97 21 / 91-33 47 E-mail Erich.Banz@schaeffler.com</p>	Slovakia	<p>FAG International Sales and Service FAG Slovak Republic Nevádzova 5</p> <p>Bratislava821 01 Slovakia Phone +(421) 2 / 43 294 260 Fax +(421) 2 / 43 330 820 E-mail fag@fag.sk</p> <p>INA loziska, spol. s r.o. ISK ul. Dr. G. Schaefflera</p> <p>Kysucké Nové Mesto024 01 Slovakia Phone +(421) 41 / 4 20 59 11 Fax +(421) 41 / 4 20 59 18 E-mail ina-loziska@ina.sk</p>
Saudi Arabia	<p>Schaeffler KG Region EMEA (Naher Osten) Georg-Schäfer-Straße 30</p> <p>Schweinfurt97421 Germany Phone +(49) 97 21 / 91-35 27 Fax +(49) 97 21 / 91-33 47 E-mail Josef.Reiher@schaeffler.com</p>	Slovenia	<p>INA kotalni lezaji Maribor IVM Glavni trg 17/b</p> <p>Maribor2000 Slovenia Phone +(386) 2 / 22 82-070 Fax +(386) 2 / 22 82 07 5 E-mail info@ina-lezaji.si</p>
Senegal	<p>Schaeffler KG FAG Region EMEA(Afrika + Irak) Georg-Schäfer-Straße 30</p> <p>Schweinfurt97421 Germany Phone +(49) 97 21 / 91-30 85 Fax +(49) 97 21 / 91-33 47 E-mail Erich.Banz@schaeffler.com</p>	Solomon Islands	<p>FAG New Zealand FAG New Zealand Auckland 6 Te Apunga Place Mt Wellington Auckland1706 New Zealand Phone +(64) 9 270 1837 Fax +(64) 9 270 1839 E-mail David.Nevin@au.fag.com</p>
Serbia-Montenegro	<p>FAG Beograd FAG Serbien-Montenegro Branka Krsmanovica 12</p> <p>Beograd11118 Serbia-Montenegro Phone +(381) 11 308 87 82 Fax +(381) 11 308 87 75 E-mail fagbgdyu@sezampro.yu</p>		



Somalia	<p>FAG South Africa (Pty) Ltd FSA 1 End Street Ext. Corner Heidelberg Road</p> <p>Johannesburg2000 South-Africa Phone +(27) 11 334 16 42 Fax +(27) 11 334 21 13 E-mail inquiries@ina.co.za</p>	Sudan	<p>Schaeffler KG FAG Region EMEA(Afrika + Irak)) Georg-Schäfer-Straße 30</p> <p>Schweinfurt97421 Germany Phone +(49) 97 21 / 91-30 85 Fax +(49) 97 21 / 91-33 47 E-mail Erich.Banz@schaeffler.com</p>
South-Africa	<p>FAG South Africa (Pty) Ltd FSA 1 End Street Ext. Corner Heidelberg Road</p> <p>Johannesburg2000 South-Africa Phone +(27) 11 334 16 42 Fax +(27) 11 334 21 13 E-mail inquiries@ina.co.za</p> <p>INA Bearings (Pty.) Ltd. South Africa ISA Caravelle Street Walmer Industrial Port Elizabeth6001 South-Africa Phone +(27) 41 / 5 01 28 00 Fax +(27) 41 / 5 81 04 38 E-mail inquiries@ina.co.za</p>	Suriname	<p>Schaeffler Brasil Ltda. IBR Av. Independência, nr. 3500 Bairro Iporanga Sorocaba18087-101 Brazil Phone +(55) 15 / 33 35 15 00 +(55) 15 / 33 35 15 01 Fax +(55) 15 / 33 35 19 60 +(55) 15 / 33 35 19 96 E-mail dvendas@br.ina.com</p>
Spain	<p>Schaeffler Iberia, s.l. IRE Polígono Ind. Pont Reixat</p> <p>Sant Just Desvern08960 Spain Phone +(34) 93 / 4 80 34 10 Fax +(34) 93 / 3 72 92 50 E-mail marketing.es@schaeffler.com</p>	Swaziland	<p>FAG South Africa (Pty) Ltd FSA 1 End Street Ext. Corner Heidelberg Road</p> <p>Johannesburg2000 South-Africa Phone +(27) 11 334 16 42 Fax +(27) 11 334 21 13 E-mail inquiries@ina.co.za</p>
Sri Lanka	<p>Schaeffler KG Region EMEA (Ost Asien) Georg-Schäfer-Straße 30</p> <p>Schweinfurt97421 Germany Phone +(49) 97 21 / 91-48 03 Fax +(49) 97 21 / 91-33 47 E-mail Werner.Mauder@schaeffler.com</p>	Sweden	<p>Schaeffler Sverige AB INS Charles gata 10</p> <p>Arlandastad195 61 Sweden Phone +(46) 8 / 59 51 09 00 Fax +(46) 8 / 59 51 09 60 E-mail info@se.ina.com</p>
St. Kitts and Nevis	<p>Rodamientos FAG, S.A. de C.V. FAG Dominica 11511 Interchange Circle South</p> <p>MiramarFl 33025 USA Phone +(1) 954-7 44 34 44 Fax +(1) 954-7 44 34 76 E-mail reinhart_h@us.fag.com</p>	Switzerland	<p>HYDREL GmbH HYD Badstrasse 14</p> <p>Romanshorn8590 Switzerland Phone +(41) 71 / 4 66 66 66 Fax +(41) 71 / 4 66 63 33 E-mail info@hydrel.ch</p>
St. Vincent and the Grenadines	<p>Rodamientos FAG, S.A. de C.V. FAG Dominica 11511 Interchange Circle South</p> <p>MiramarFl 33025 USA Phone +(1) 954-7 44 34 44 Fax +(1) 954-7 44 34 76 E-mail reinhart_h@us.fag.com</p>	Taiwan	<p>FAG Representative Office Taiwan FAG Taiwan Rm 127, 4th Floor Keelung Road - Sec. 1 Taipei Taiwan Phone +(886) 2 / 8780-1126 Fax +(886) 2 / 8780-1127 E-mail bob.tung@tw.fag.com</p>
		Tajikistan	<p>FAG Representative Office Russia FAG Russia Leningradskiy pr, 37A Bld. 14, 10. floor Moscow125167 Russia Phone +(7) 95 / 737 3281 Fax +(7) 95 / 737 3298 E-mail fagmoskau@col.ru</p>

Tanzania	<p>Schaeffler KG FAG Region EMEA(Afrika + Irak)) Georg-Schäfer-Straße 30</p> <p>Schweinfurt97421 Germany Phone +(49) 97 21 / 91-30 85 Fax +(49) 97 21 / 91-33 47 E-mail Erich.Banz@schaeffler.com</p>	<p>Schaeffler KG FAG Delegation Turkey FAG Turkey AYDIN SOK 4 DAGLI APT. D : 4 1. LEVENT Istanbul34340 Turkey Phone +(90) 212 / 280 77 98 Fax +(90) 212 / 280 94 45 E-mail fag@fag.com.tr</p>
Thailand	<p>Schaeffler (Thailand) Co., Ltd. FTB 283/92 Sukhumvit Soi 55 Rd. - Home Place Office Bldg.</p> <p>Bangkok10110 Thailand Phone +(66) 2 712 9801 Fax +(66) 2 712 9806 E-mail sales@th.fag.com</p>	<p>Turkmenistan</p> <p>FAG Representative Office Russia FAG Russia Leningradskiy pr, 37A Bld. 14, 10. floor Moscow125167 Russia Phone +(7) 95 / 737 3281 Fax +(7) 95 / 737 3298 E-mail fagmoskau@col.ru</p>
Togo	<p>Schaeffler KG FAG Region EMEA(Afrika + Irak)) Georg-Schäfer-Straße 30</p> <p>Schweinfurt97421 Germany Phone +(49) 97 21 / 91-30 85 Fax +(49) 97 21 / 91-33 47 E-mail Erich.Banz@schaeffler.com</p>	<p>Tuvalu</p> <p>FAG New Zealand FAG New Zealand Auckland 6 Te Apunga Place Mt Wellington Auckland1706 New Zealand Phone +(64) 9 270 1837 Fax +(64) 9 270 1839 E-mail David.Nevin@au.fag.com</p>
Tonga	<p>FAG New Zealand FAG New Zealand Auckland 6 Te Apunga Place Mt Wellington Auckland1706 New Zealand Phone +(64) 9 270 1837 Fax +(64) 9 270 1839 E-mail David.Nevin@au.fag.com</p>	<p>Uganda</p> <p>Schaeffler KG FAG Region EMEA(Afrika + Irak)) Georg-Schäfer-Straße 30</p> <p>Schweinfurt97421 Germany Phone +(49) 97 21 / 91-30 85 Fax +(49) 97 21 / 91-33 47 E-mail Erich.Banz@schaeffler.com</p>
Trinidad and Tobago	<p>Rodamientos FAG S.A. de C.V. FAG Mexico Region Mittelamerika Paseo de la Reforma 383 - Despacho 701 y 702 Colonia Cuauhtemoc Mexico D.F.DF 06500 Mexico Phone +(52) 55-52 08 12 08 Fax +(52) 55 52 08 08 36 E-mail Pubanz_t@us.fag.com</p>	<p>Ukraine</p> <p>FAG Representative Office Ukraine FAG Ukraine Ul. Schelkowitzchnaja 16B, of. 29-30</p> <p>Kiev01024 Ukraine Phone +(380) 44-253 72 60 Fax +(380) 44-253 96 42 E-mail office@fag.kiev.ua</p>
Tunisia	<p>FAG AFRIQUE DU NORD FAG Tunisia 66 Avenue de Carthage</p> <p>Tunis1000 Tunisia Phone +(216) 1 / 34 14 48 Fax +(216) 1 / 33 67 04 E-mail michael.kuehn@schaeffler.com</p>	<p>United Arab Emirates</p> <p>FAG ISS GmbH - Dubai FAG DUBAI Office No.1001, Five Towers Al Maktoum Street Dubai United Arab Emirates Phone +(971) 4 - 2 24 73 24 Phone 9 71 - 5 06 44 10 73 Fax +(971) 4 - 2 24 73 25 E-mail fagdubai@emirates.net.ae</p>
Turkey	<p>INA Rulmanlari Ticaret Ltd. Sirketi ITR Aydin Sokak Dagli Apt. 4/4 1. Levent Istanbul34340 Turkey Phone +(90) 212 / 2 79 27 41 Fax +(90) 212 / 2 81 66 45 E-mail inaturk@tr.ina.com</p>	<p>Uruguay</p> <p>Schaeffler Brasil Ltda. IBR Av. Independência, nr. 3500 Bairro Iporanga Sorocaba18087-101 Brazil Phone +(55) 15 / 33 35 15 00 +(55) 15 / 33 35 15 01 Fax +(55) 15 / 33 35 19 60 +(55) 15 / 33 35 19 96 E-mail dvendas@br.ina.com</p>



USA FAG Bearings Corporation
FAG USA Danbury
200 Park Avenue - P.O. Box 1933

Danbury06813-1933
USA
Phone +(1) (203) 790 54 74
Fax +(1) (203) 830 81 71
E-mail dibartolomeo_d@us.fag.com

Schaeffler Automotive
TRY
1750 East Big Beaver Road

Troy48083
USA
Phone +(1) (248) 528 4800
Fax +(1) (248) 528 4827

Schaeffler Group USA Inc.
IFM
308 Springhill Farm Road

Fort Mill29715
USA
Phone +(1) 803 / 548-8500
Fax +(1) 803 / 548-8599
E-mail ind-sales@us.ina.com

Schaeffler Group USA Inc., FAG Joplin Plant
FAJ
3900 Range Line Road

Joplin64804
USA
Phone +(1) 417 / 781-3600
Fax +(1) 417 / 781-3605

The Barden Corporation
BCD
200 Park Avenue
P.O. Box 2449
Danbury06813-2449
USA
Phone +(1) (203) 744 22 11
Fax +(1) (203) 744 37 56
E-mail dibartolomeo_d@us.fag.com

Uzbekistan FAG Representative Office Russia
FAG Russia
Leningradskiy pr, 37A
Bld. 14, 10. floor
Moscow125167
Russia
Phone +(7) 95 / 737 3281
Fax +(7) 95 / 737 3298
E-mail fagmoskau@col.ru

Vanuatu FAG New Zealand
FAG New Zealand Auckland
6 Te Apunga Place
Mt Wellington
Auckland1706
New Zealand
Phone +(64) 9 270 1837
Fax +(64) 9 270 1839
E-mail David.Nevin@au.fag.com

Venezuela FAG Interamericana AG - Delegación II
FAG Venezuela Valencia
Av. Fuerza Aerea
Residencias Guaicamacuto Torre C, Apto.
PB-4 Maracay
Valencia
Venezuela
Phone +(58) 58 241 8681637
Fax +(58) 58 241 8681637
E-mail jairo.ra@cantv.net

Schaeffler Venezuela, C.A.
Venezuela
Torre Platinum B.O.D., Piso 14, Oficina 14-1,
Urbanización San José de Tarbes,
Valencia
Venezuela

Vietnam FAG South East Asia Pte Ltd
FAG Vietnam
Vietnam Representative Office
23 Phung Khac Khoan St., Dist.1,
Ho Chi Minh City
Vietnam
Phone +(84) 8-822 0699
Fax +(84) 8-822 0682
E-mail minh.tam@vn.fag.com

Zambia FAG South Africa (Pty) Ltd
FSA
1 End Street Ext. Corner Heidelberg Road

Johannesburg2000
South-Africa
Phone +(27) 11 334 16 42
Fax +(27) 11 334 21 13
E-mail inquiries@ina.co.za

Zimbabwe FAG South Africa (Pty) Ltd
FSA
1 End Street Ext. Corner Heidelberg Road

Johannesburg2000
South-Africa
Phone +(27) 11 334 16 42
Fax +(27) 11 334 21 13
E-mail inquiries@ina.co.za